

# Fitting Instructions

## Suzuki Jimny

### *Radius Arm to Diff Mount Bushing Castor increase*

---

This kit is designed to provide an increase in castor of approximately  $2\frac{1}{2}^{\circ}$  for the front axle.

- This kit will be required if the vehicle has been raised from its original height
- Wheel-align the vehicle before the job is started and note the castor settings;
- **Important** Only one radius arm should be removed from the vehicle at a time and this step should be performed with the vehicle on the ground or on a four-post hoist.
- Use a bottle jack or similar to stop the diff from twisting and remove arm from vehicle
- Press the original bushings from the arm and discard
- Deburr the housings as necessary.
- Lay the arm over the 1:1 template supplied and time the bushes into the arm housing, so they align with the centre marks on the sheet. **See FIG 1**
- When aligned mark the bushing and the arm with a paint pen or similar
- Press bushings into arm so the shell part sits flush with the arm **see FIG 2**
- For reassembly it is recommended that you bolt the arm to the diff then raise the rear of the arm up to the chassis and bolt in place.
- Repeat disassembly and bush fit up procedure to the other arm
- Wheel align vehicle and note settings – you should achieve a castor increase of at least  $2\frac{1}{2}^{\circ}$
- Retention all bolts at 1000km check.

# Fitting Instructions

---

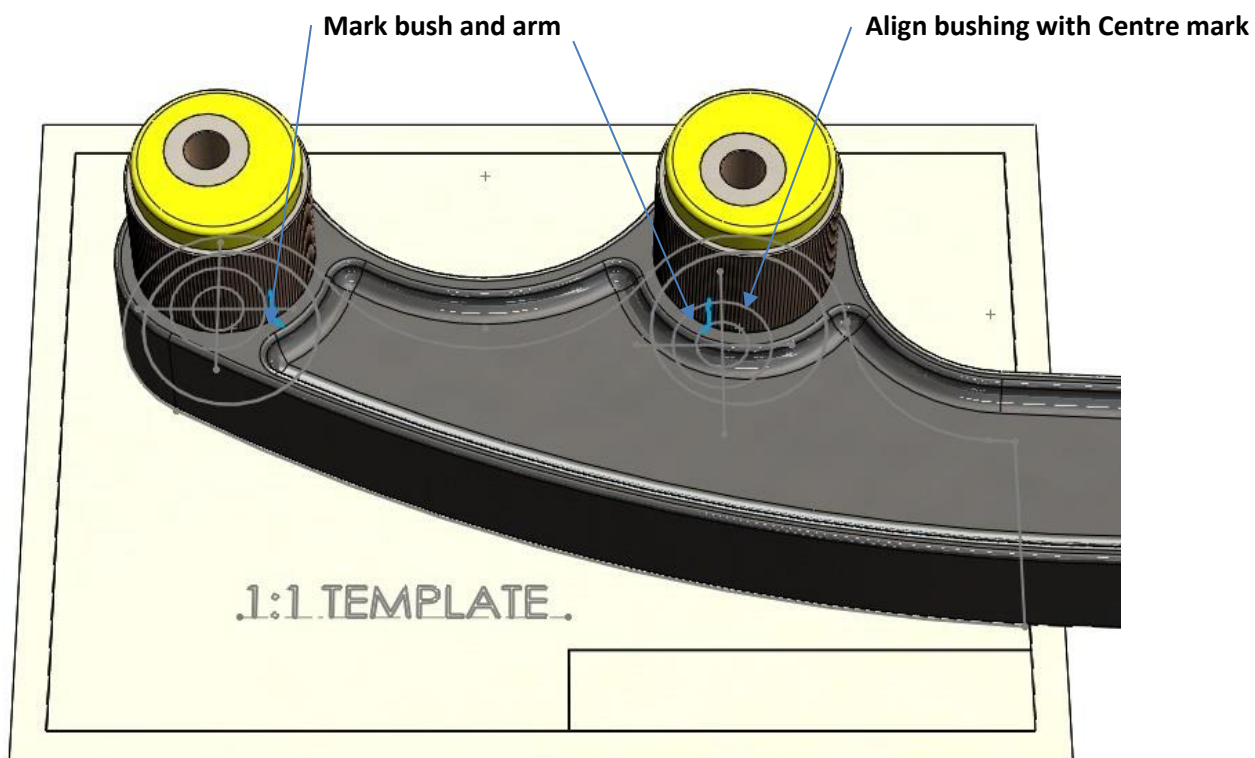

FIG 1



Press bushes till the shell is flush with the arm

FIG 2