



OLD MANEMU

4X4 SUSPENSION BY ARB

INTERNATIONAL APPLICATION CATALOGUE

Number 38

September 2018

OME FEATURES

NITROCHARGER SPORT SHOCK ABSORBERS

LARGE BORE 35MM TWIN TUBE DESIGN - Allows greater oil volume for cooling and sustained valving performance and strong 1.6mm outer tube construction protects the vital internal components from damage.

LARGE 18MM HARDENED CHROME PISTON ROD - Strong enough to handle any load or harsh conditions expected from your 4x4.

TRIPLE LIP CHECK VALVE OIL SEAL – MK2 - The latest technology in oil seal design – physically larger with quantum improvements in durability, oil and gas retention with much greater resistance to heat so it keeps working under the harshest conditions.

TEFLON IMPREGNATED LOW FRICTION ROD GUIDE -

The latest refinement in rod guide design further reduces heat build up and maintains performance.

TEFLON INFUSED BRONZE ROD GUIDE SLIP RING - A new component that maintains consistent and uniform performance by providing a tight and uniform fit between the piston rod and rod guide.

MULTI DEFLECTIVE DISC VALVING SYSTEM - A unique and new valving system that features multiple disc valving control at the base of the shock and on both sides of the piston rod. This allows the OME engineers more valving options for better ride quality and handling control.

35MM HIGH FLOW TEFLON BANDED PISTON - New low friction design has less restrictive oil flow through the piston, reduces heat build up and aeration of the oil that leads to fade.

VEHICLE SPECIFIC VALVING - OME shock absorber's performance stand head and shoulders over its competitors because many hours of OME engineering valving work have been put into each and every shock absorber to ensure our customers get the best ride and handling their vehicle can have.

POLYETHYLENE DIRT SHIELD - Impact resistant, polyethylene dirt shield provides additional protection from stone chips and off road debris.

NITROGEN GAS - Increases the temperature operating range and improves oil flow through the valving, ensuring optimum performance.

SUPPLEMENTARY WELDS - For strength and reliability, all mounts have supplementary welds.

NITROCHARGER SHOCK ABSORBERS

GIANT 18MM CHROMED SHAFT - Indestructible for Australia's rugged off roading. Induction hardened then hard chromed to a superfine finish.

NITROGEN GAS - The gas pressure keeps the oil cohesive under all situations.

TWIN TUBE DESIGN - 33% thicker outer tube insures that rocks do not damage internal operating components. This design also allows for a greater volume of oil which keeps shock cooler.

35MM SEVEN STAGE COMPRESSION VALVE - Delivers all the subtleties of compression rates for the best ride and handling.

CHECK VALVE SEAL - The latest in seal technology, this shaft seal significantly improves gas retention whilst offering excellent longevity.

GLACIER BUSH - A Teflon coated rod guide bush - significantly reduces heat build up in the rod guide area, developed from the Emu's off road racing programme.

GIANT 35MM TEFLON BANDED PISTON - A new four stage coil sprung rebound valve system to control vehicle bounce.

SUPPLEMENTARY WELDS - On all mounting eyes & pins for maximum shock absorber mount strength.

STONEGUARD - Protects oil seal and piston rod against stone and dirt damage.

COIL SPRINGS

X5K MICRO-ALLOYED SPRING STEEL - New generation high strength spring steel grade designed to withstand higher operating stresses with superior resistance to sag and improved toughness and corrosion fatigue properties.

SHOT PEENED - To reduce stress, which greatly enhances spring life.

DOUBLE SCRAGGED - To eliminate spring sag.

VARIABLE AND CONSTANT RATE - Designs used to obtain optimum ride comfort and load carrying capabilities.

STEERING STABILISERS

COIL SPRUNG 9 STAGE VALVING - For optimum performance.

35MM PISTON & BORE - Greater oil volume giving better damper performance.

TWIN TUBE DESIGN - Protects the internal components against stone damage.

STEEL STONEGUARD - Protects the piston rod against stone damage.

FOAM CELL - Keeps the oil at the valving to prevent fade.

ORIGINAL MOUNTS - All mounts are of similar design to original stabilisers for ease of fitment.

LEAF SPRINGS

FLAT AXLE SEAT AREA - Lowers spring stress whilst retaining spring free camber height. Unique to most OME springs.

ANTI FRICTION INTER LEAF LINERS - Used where applicable to reduce friction between spring leaves giving better ride comfort and increased spring life.

SHOT PEENED - On the tension side of all leaves to double spring life.

DRAW TAPERED & DIAMOND CUT LEAVES - For reduced interleaf friction and improved load distribution in the load bearing area.

GRAPHITE COATED - For further reduced friction.

MILITARY WRAPPED - For extra safety (where fitment permits).

LOOSE CLAMPED - For smooth & quiet operation.

URETHANE BUSHES - LEAF SPRING

PREMIUM GRADE - Not all bushes are the same - OME bushes are precision moulded in captive moulds to ensure exact tolerances for long bush life.

SPLINES - Ensures the best fit by taking up irregularities in spring eyes.

UNIQUE OME DESIGN - Clever lip seal and shoulder design prevents dirt penetrating between bush shoulder and shackle face.

GREASABLE SHACKLES

REDUCED WEAR - Greasable shackles reduce shackle pin deterioration, increase bush life, enables easy maintenance and improve ride and handling.

ANTI INVERSION FACILITY - Built in feature on all LandCruiser greasable shackles.

SERVICING - Simple & effective.

WARRANTY:

For a copy of ARB's Warranty Policy, ARB Products: Warranty Against Defects, please visit the ARB website - www.arb.com.au

CONTENTS



	PAGE
GUIDE TO SELECTION	8
NITROCHARGER SPORT SELECTION	9
NITROCHARGERS & STEERING STABILISER APPLICATIONS	14
COMPACT AWD - OME SPRING & SHOCK ABSORBER RANGE	18
LTR REMOTE CANISTER SELECTION.....	19
ARMOURED APPLICATION.....	
<u>NISSAN PATROL Y62 - 4.5T GVM</u>	20
<u>TOYOTA LANDCRUISER 200 SERIES - 4.5T GVM</u>	20
SUSPENSION APPLICATIONS	
CHRYSLER JEEP	
<u>COMMANDER XK 2006 To 2010</u>	25
<u>CHEROKEE XJ WAGON 1984 To 2001</u>	25
<u>CHEROKEE/LIBERTY KK 2008 To 2013</u>	26
<u>CHEROKEE/LIBERTY KJ 2002 To 2007</u>	26
<u>GRAND CHEROKEE WK2 2016 On</u>	21
<u>GRAND CHEROKEE WK2 2011 To 2015</u>	22
<u>GRAND CHEROKEE WH/WK 2005 To 2010</u>	23
<u>GRAND CHEROKEE WJ/WG 1999 To 2004</u>	23
<u>GRAND CHEROKEE ZJ 1993 To 1998</u>	24
<u>WRANGLER JK 2 DOOR 2006 On</u>	29
<u>WRANGLER JK 4 DOOR 2006 On</u>	30
<u>WRANGLER JK - OFF ROAD USE ONLY</u>	31
<u>WRANGLER TJ & TJ UNLIMITED 1997 To 2006</u>	27
<u>WRANGLER YJ 1986 To 1996</u>	28
FORD	
<u>COURIER/RANGER 1 TONNE 1985 To 2005 ALL MODELS (not USA manufact. models)</u>	33
<u>EVEREST 2015 On</u>	34
<u>EXPLORER 1996 To 2001 REAR LEAF SPRING MODELS</u>	35
<u>F250/F350 2011 To 2017</u>	35
<u>F250/F350 2008 To 2010</u>	36
<u>F250/F350 2005 To 2008 ALL MODELS</u>	37
<u>F250/F350 1999 To 2004 ALL MODELS</u>	38
<u>RANGER PX 2011 On</u>	32
<u>RANGER PJ/PK 12/2006 To 2011 ALL MODELS (not USA manufact. models)</u>	33
HOLDEN / GM	
<u>COLORADO 2012 On ALL MODELS</u>	42
<u>COLORADO RC 2008 To 2011 ALL MODELS</u>	43
<u>COLORADO 7 2013 To 2016/TRAILBLAZER 2017 On ALL MODELS</u>	41
<u>DROVER ALL MODELS (not USA manufactured model)</u>	44
<u>GM FRONTERA 5 DOOR 1999 To 6/2003</u>	40
<u>GM FRONTERA 2 & 4 DOOR UT MODELS 1995 To 1998</u>	41
<u>JACKAROO/TROOPER & MONTEREY 3/2001 To 2004 SWB & LWB</u>	39
<u>JACKAROO/TROOPER & MONTEREY 1992 To 2/2001 SWB & LWB</u>	39
<u>JACKAROO 1982 To 3/1992 ALL MODELS</u>	40
<u>RODEO RA 2003 To 2011 ALL MODELS (not USA manufactured model)</u>	43
<u>RODEO To 2003 ALL MODELS (not USA manufactured model)</u>	44
HUMMER	
<u>HUMMER H3</u>	45

CONTENTS



	PAGE
SUSPENSION APPLICATIONS (continued)	
HYUNDAI	
GALLOPER To 1991 REAR LEAF SPRING MODELS	59
GALLOPER 1989 To 1991 REAR COIL SPRING MODELS	60
TERRACAN 2001 On	46
ISUZU	
DMAX 2012 On ALL MODELS	42
DMAX 2008 To 2011 ALL MODELS	43
DMAX To 2003 ALL MODELS (not USA manufactured model)	44
MU-X 2013 On ALL MODELS	41
RODEO WAGON 1999 To 6/2003 (USA)	40
RODEO WAGON 1995 To 1998 (USA)	41
TROOPER 1982 To 3/1992 ALL MODELS	40
KIA	
SORENTO BL To 2009	46
LADA	
NIVA	46
LAND ROVER	
90 SERIES	53
DEFENDER & COUNTY 110	49
DEFENDER 110 LONG TRAVEL	50
DEFENDER 130	51
DEFENDER 130 LONG TRAVEL	52
DISCOVERY 3 2005 On ALL COIL MODELS	47
DISCOVERY 1999 To 2004 ALL COIL SUSPENSION MODELS	47
DISCOVERY To 1998	48
RANGE ROVER To 5/1995	48
MAZDA	
B SERIES 1 TONNE 1987 To 2006 ALL MODELS	55
BT-50 2011 On	54
BT-50 1 TONNE 12/2006 To 2011 ALL MODELS	55
MERCEDES	
G-WAGON G350 BLUETECH/G55 AMG MODELS	56
MITSUBISHI	
CHALLENGER/MONTERO SPORT KH 2010 On	63
CHALLENGER/MONTERO SPORT 2000 To 2008 LWB COIL REAR MODELS	63
CHALLENGER V6 1998 To 2000 (REAR LEAF SPRING MODELS)	64
MONTERO SPORT 1989 To 1991 (USA)	60
MONTERO SPORT WAGON PA 1998 To 2000 (REAR LEAF SPRING MODELS)	64
PAJERO 2007 On ALL LWB MODELS	57
PAJERO/MONTERO 2000 To 2006 ALL LWB MODELS	57
PAJERO/MONTERO 2000 On ALL SWB MODELS	58
PAJERO/MONTERO 1991 To 1999 ALL SWB & LWB REAR LEAF SPRING MODELS	58
PAJERO/MONTERO 1991 To 1999 ALL LWB REAR COIL SPRING MODELS	59
PAJERO/MONTERO 1991 To 1999 ALL SWB REAR COIL SPRING MODELS	59
PAJERO/MONTERO To 1991 REAR LEAF SPRING MODELS	59

CONTENTS



	PAGE
SUSPENSION APPLICATIONS (continued)	
MITSUBISHI (continued).....	
<u>PAJERO CHALLENGER 1989 To 1991 REAR COIL SPRING MODELS</u>	60
<u>TRITON/L200 MQ ALL 4X4 MODELS</u>	60
<u>TRITON/L200 ML & MN 2006 To 2015 ALL MODELS</u>	61
<u>TRITON/L200 MK 10/1996 To 2006 ALL MODELS</u>	62
<u>TRITON/L200 To 1996 ALL MODELS</u>	62
NISSAN.....	
<u>FRONTIER 2005 On ALL MODELS (USA)</u>	77
<u>NAVARA D23 NP300 2015 On</u>	76
<u>NP300 2008 To 2014 ALL MODELS</u>	77
<u>NAVARA D40 2005 On ALL MODELS</u>	77
<u>NAVARA D22 10/2002 On ALL MODELS</u>	77
<u>NAVARA D21 & D22 To 8/2002 ALL MODELS</u>	78
<u>PATHFINDER R51 2005 To 2014 (not USA manufactured model)</u>	78
<u>PATHFINDER R50 1996 To 2005 V6 MODELS</u>	79
<u>PATHFINDER To Late 1995 ALL MODELS</u>	79
<u>PATROL Y62 2010 On (non HBMC models)</u>	65
<u>PATROL GU Y61 ALL LWB MODELS</u>	67
<u>PATROL Y60 & Y61 LWB - OFF ROAD USE ONLY</u>	66
<u>PATROL GU Y61 ALL SWB MODELS</u>	68
<u>PATROL GU Y61 ALL COIL CAB CHASSIS MODELS</u>	69
<u>PATROL GU Y61 CAB CHASSIS COIL: FRONT/LEAF: REAR</u>	70
<u>PATROL GQ Y60 ALL SWB & LWB MODELS</u>	71
<u>PATROL GQ Y60 CAB CHASSIS COIL SPRING MODELS</u>	72
<u>PATROL GQ Y60 UTE & CAB CHASSIS LEAF SPRING MODELS</u>	73
<u>PATROL MQ 260 LWB (SPANISH BUILT ALL 2.8TD MODELS)</u>	74
<u>PATROL MQ M60 ALL MODELS</u>	75
<u>TERRANO II R20 1996 To 2005</u>	79
<u>XTERRA 2005 On MODELS</u>	80
SSANGYONG.....	
<u>KORANDO 1995 To 2005</u>	81
<u>MUSSO 1995 To 2005</u>	81
<u>SPORT UTILITY 1995 To 2005</u>	81
SUZUKI.....	
<u>EQUATOR (USA)</u>	83
<u>GRAND VITARA 8/2005 To 2015</u>	81
<u>GRAND VITARA To 2005</u>	81
<u>JIMNY SN413</u>	85
<u>SIERRA/SAMURAI ALL LEAF SPRING MODELS (SJ413)</u>	84
<u>SANTANA SAMURAI To 2004 SWB & LWB MODELS</u>	85
<u>VITARA WAGON 1988 To 2005 V6 PETROL ENGINE MODEL</u>	82
<u>VITARA WAGON 1988 To 2005 4 CYLINDER PETROL ENGINE MODEL</u>	82
<u>VITARA SWB To 2005</u>	82
<u>XL7 WAGON 2001 To 2005</u>	83

CONTENTS



SUSPENSION APPLICATIONS (continued)

PAGE

TOYOTA	
4 RUNNER 2010 On (USA)	116
4 RUNNER 2003 To 2010 (USA)	117
4 RUNNER/SURF 1996 To 2002 (USA)	117
4 RUNNER 1990 To 1996 (To 1995 in USA) IFS REAR COIL SPRING MODELS	118
4 RUNNER 1986 To 1990 (To 1989 in USA) IFS REAR LEAF SPRING MODELS	118
BUNDERA RJ70 11/1984 To 1990	105
FJ CRUISER 2010 On	96
FJ CRUISER 2006 To 2010	97
FORTUNER 2015 On	97
FORTUNER 2004 To 2015	98
HILUX 2015 On ALL MODELS	111
HILUX/VIGO 2005 To 2015 ALL MODELS	112
HILUX/TIGER 1997 To 2004 ALL MODELS	113
HILUX & 4 RUNNER PRE 1997 ALL LEAF SPRING MODELS	114
HILUX PRE 1997 EXTRA CAB & DUAL CAB SR5 IFS & REAR LEAF MODELS	115
LANDCRUISER 200 SERIES WAGON (not AHC models)	86
LANDCRUISER 100 SERIES INDEPENDENT FRONT SUSPENSION (not AHC models)	87
LANDCRUISER 105 SERIES WAGON LIVE AXLE FRONT SUSPENSION MODEL	88
LANDCRUISER 80 SERIES WAGON LIVE AXLE FRONT SUSPENSION MODEL	88
LANDCRUISER 80 SERIES & 105 SERIES - OFF ROAD USE ONLY	89
LANDCRUISER 79 SERIES SINGLE CAB (not 1GR-FE models)	102
LANDCRUISER 78 SERIES (not 1GR-FE models)	101
LANDCRUISER 76 SERIES WAGON	100
LANDCRUISER 75 SERIES (not 1GR-FE models)	103
LANDCRUISER 74 SERIES SWB & MWB	105
LANDCRUISER 73 SERIES SWB & MWB	105
LANDCRUISER 70 SERIES SWB & MWB	105
LANDCRUISER 70 SERIES DUAL CAB (not 1GR-FE models)	99
LANDCRUISER 62 SERIES	106
LANDCRUISER 61 SERIES	106
LANDCRUISER 60 SERIES	106
LANDCRUISER 47 SERIES ALL LWB MODELS	107
LANDCRUISER 45 SERIES ALL LWB MODELS	107
LANDCRUISER 42 SERIES SWB	108
LANDCRUISER 40 SERIES SWB	108
LANDCRUISER HZJ71 & HZJ74 To 2007 SWB & MWB MODELS	104
LANDCRUISER II WAGON LWB	104
PRADO 150 SERIES 10/2017 On LWB COIL SPRUNG MODELS ONLY	90
PRADO 150 SERIES 2009 To 9/2017 LWB COIL SPRUNG MODELS ONLY	91
PRADO 150 SERIES 2009 On SWB COIL SPRUNG MODELS ONLY	92
PRADO 120 SERIES 4/2003 To 2009 LWB & SWB (not TEMS model)	93
PRADO 90 SERIES To 10/2002 LWB	94
TACOMA 2016 On	109
TACOMA V6 2005 To 2015	110
TACOMA V6 & 4 CYLINDER 1998 To 2004	110
TUNDRA 2007 On	95
VOLKSWAGEN	
AMAROK 2010 On ALL MODELS	119

CONTENTS



	PAGE
TECHNICAL SPECIFICATIONS	
SUSPENSION BUSH KIT SELECTION	120
DIAGRAM REFERENCE FOR SUSPENSION BUSH KITS	126
NUMERICAL SPRING & SHOCK / STRUT BUSH APPLICATIONS	128
OLD MAN EMU POLYURETHANE SPRING BUSH DIMENSIONS	132
SUSPENSION FITTING KITS	133
ADDING OR REMOVING AN EXTRA LEAF	141
REPLACEMENT MAIN OR SECOND LEAF	142
REPLACEMENT CENTRE BOLTS	144
LEAF SPRING SERVICE PARTS	145
U BOLTS	143
LEAF SPRING TRIM PACKERS	146
CLIP LINER KITS FOR LEAF SPRINGS	146
INTER-LEAF LINER KIT FOR LEAF SPRINGS	146
LEAF SPRING CENTRE BOLT SLEEVES	146
LEAF SPRING SPECIFICATIONS	147
COIL SPRING SPECIFICATIONS	150
NITROCHARGER SPORT SPECIFICATIONS	157
NITROCHARGER SPECIFICATIONS	161
SHOCK ABSORBER MOUNT TYPE	165
TORSION BAR SPECIFICATIONS	165
STEERING STABILISER SPECIFICATIONS	166
RECOMMENDED FITTING TIMES	167

© ARB Corporation Limited, Old Man Emu Division P.O. Box 105 Kilsyth, Vic. 3137 Australia.

All rights reserved. No part of this catalogue may be reproduced or copied in any form or by any means (graphic, electronic or mechanical, including photocopying, recording, taping or information systems) without the written permission of the publisher.

Terminologies & Explanations

Please note most suspension development has been carried out on Australian specification models. Therefore, some differences may exist between the same model in another country. Overseas customers will need to make allowances for these possible differences.

Supplying all items shown on suspension selection charts will ensure the system can be fitted, however, there will be vehicles which will not require all items, eg. trimming kits, caster kits, all U bolts shown, etc. Actual individual vehicle requirements can only be determined when the suspension system is fitted.

GVM - GROSS VEHICLE MASS: Set by the vehicle manufacturer and is determined by brake, axle, differential and tyre specifications. Exceeding GVM ratings can have legal and safety implications and is not recommended.

LOAD RATING - FRONT: Weights shown are maximum permissible loads with regard to accessories fitted, eg. Bull bar, winch, dual battery, etc.

LOAD RATING: The explanations below indicates the passenger and load weights that will provide optimum ride and handling.

REAR:

LIGHT LOAD: Full passenger load with luggage weights up to 150kg.

MEDIUM LOAD: Full passenger load with luggage weight varying from 200kg to 350kg.

CONSTANT LOAD: The minimum constant load shown on selection chart is required for optimum spring performance.

Please note: These loads are approximate only. Refer to individual vehicle selection for load specifications.

LIFT HEIGHT: Is shown as a guide only and equates to the amount of lift over the vehicle's original ride height. This amount can vary from vehicle to vehicle.

OE: Original Equipment, as supplied by the manufacturer of the vehicle.

SHOCK ABSORBERS: Where two part numbers are given for the same application the part with the asterisk (*) indicates the shock absorber with the firmer ride.

SPRING BUSH: OME polyurethane spring eye bushes on installation must only be greased in the bore and on the flange area and regularly thereafter with OME polyurethane grease.

STEERING STABILISER: Designed as a larger capacity replacement for the OE part and incorporates 50/50 neutral valving.

CASTER KIT: The OMECA77B, CALR1 and CALR2 kits consist of 4 eccentric bushes which are pressed into the leading arms of the vehicle. This will induce positive caster into the front geometry.

LEAF SPRINGS: A & B springs can be used to compensate for uneven vehicle weight distribution. Springs marked 'A' have a greater camber height than springs marked 'B'. 'A' type springs are generally fitted to the driver's side and 'B' springs to the passenger side.

COIL SPRINGS: A & B springs are used to compensate for uneven vehicle weight distribution. 'A' type springs are generally higher in free high than the 'B' spring. Individual coil specifications are listed in the back of this publication.

GEARBOX PACKER KIT: Designed to space down the gearbox cross member from the chassis to reduce tail shaft flange angle thereby reducing driveline vibration.

GREASABLE SHACKLES: Replacement for original shackles allow easy regular greasing of polyurethane spring eye bushes.

TRIM PACKERS: The prime purpose of a trim packer is to correct slight vehicle leaning.

VEHICLES WITH LEAF SPRINGS UNDER SLUNG: Trim packer when fitted will reduce suspension height.

VEHICLES WITH LEAF SPRINGS OVER SLUNG: Trim packer when fitted will increase suspension height.

VEHICLES WITH COIL SPRINGS: Polyurethane trim packer main purpose is to correct slight vehicle trimming problems and will increase ride height when fitted.

NITROCHARGER SPORT SELECTION

SELECTION ADVICE

Where there is a choice of part numbers it is important the right selection is made with consideration given to type of spring rates and customer applications.

Firm Valving

The firm part number should be selected whenever heavy rate springs are fitted, as the valving has been specifically developed to control the higher spring rates. The firmer valving will provide better control when cornering, while also preventing axle bounce over rough roads.

If a softer valved selection is fitted with a heavy rate spring the vehicle's rebound handling will be reduced. This will be evident by axle bounce over rough roads, dipping under braking or cornering and wallowing over undulating roads.

Soft Valving

Valved specifically for light to medium rate springs. Most suitable for customers wanting a comfortable ride and regularly carry light to medium loads. Under full GVM load a slight amount of body roll during cornering and highway speed manoeuvring can occur.

A RECOMMENDATION FOR CUSTOMERS BUYING 4 REPLACEMENT SHOCK ABSORBERS

By the time a customer has decided to replace the old and well used original shock absorbers there is every chance that the original springs are also ready for replacement.

It should be explained to the customer that if their springs are sagged and tired that this would cause the shock absorbers to work a lot harder.

Therefore, the life expectancy of the shock absorbers will be considerably shortened and, when loaded, ride and handling qualities will also be reduced.

REMEMBER: A good set of shock absorbers will not overcome a bad set of springs.

YEAR	VEHICLE DESCRIPTION	OME NITROCHARGER SPORT SHOCKS & STRUTS		STEERING STABILISERS
		FRONT	REAR	
CHRYSLER JEEP				
2016 on	Grand Cherokee WK2	90035 ⁵ LHS 90036 ⁵ RHS	60124 ⁵ / 60125 ⁵ / 60126 ⁵ / 60127 ⁵	
2011 to 2015	Grand Cherokee WK2	90026 ⁵	60124 ⁵ / 60125 ⁵ / 60126 ⁵ / 60127 ⁵	
1999 to 2004	Grand Cherokee WJ & WG	60087	60088	
All	Grand Cherokee ZJ	60092	60093	OMESD40
2008 to 2013	Cherokee/Liberty KK All Models	90009 ¹¹	60069	
2002 to 2007	Cherokee/Liberty KJ ALL Models (OME Springs)	90009 ¹¹	60069	
1984 to 2001	Cherokee XJ - Petrol & Diesel	60052	60053	OMESD40 ⁹
2006 on	Wrangler JK All Models Off Road Use ONLY ³²	60066M (mid Length) / 60066L (long)	60067L	OMESD48
2006 on	Wrangler JK - All Models	60066	60067	OMESD48
1997 to 2006	Wrangler TJ	*60047 / 60046	*60049 / 60048 ¹⁰	OMESD40 ⁹
1986 to 1996	Wrangler YJ	60098	60099	OMESD40
DAIHATSU				
1992 to 1997	Feroza II F310	60040	N/A	
1988 to 1992	Feroza I F300	60040	N/A	
1993 on	Rocky F78 Wide Track	60031	N/A	OMESD31 ¹² '86 on
FORD				
2015 on	Everest	*90020 ¹⁷ / 90019 ¹⁷	*60145 ¹⁶ / 60144 ¹⁶	
2011 on	Ranger PX	*90020 ¹³ / 90019 ¹³	*60102 / 60101 *60101 / 60023	
12/06 to 2011	Ranger PJ/PK All Models	60022 ²⁶	*60102 / 60023	
2011 to 2017	F250 & F350 Diesel	60123 / 60121 ¹⁵	60122	
2008 to 2010	F250 & F350 Diesel	60123 / 60121 ¹⁵	60122	
1985 to 2005	Courier/Ranger Pick Up not USA manufactured model	60022 ⁴	60023	
1987 to 1993	Raider Wagon	60022	60023	
All	Maverick Wagon & Hard Top	*60013 / 61012	*60015 / 61014	To 8/89 OMESD34 9/89 on OMESD36
HOLDEN/ISUZU/CHEVY				
2017 on	Trailblazer	*90023 ¹⁷ / 90022 ¹⁷	*60131 ¹⁸ / 60130 ¹⁸	
2013 on	MU-X	*90023 ¹⁷ / 90022 ¹⁷	*60131 ¹⁸ / 60130 ¹⁸	
2013 to 2016	Colorado 7	*90023 ¹⁷ / 90022 ¹⁷	*60131 ¹⁸ / 60130 ¹⁸	
2012 on	GM/Isuzu Pick Up Models Colorado / DMAX	*90023 ¹⁷ / 90022 ¹⁷	*60117 / 60116	
2008 to 2011	GM/Isuzu Pick Up Models Colorado RC / DMAX	60031	*60064 / 60032	
2003 to 2011	Rodeo Pick Up RA Models	60031	*60064 / 60032	

Cont.

NITROCHARGER SPORT SELECTION

OME NITROCHARGER SPORT SHOCKS & STRUTS

STEERING STABILISERS

YEAR	VEHICLE DESCRIPTION	FRONT	REAR	
HOLDEN/ISUZU/CHEVY (continued)				
7/81 to 2003	Rodeo/Isuzu Pick Up KB4, KBD4 & TFS	60031	60064 / 60032	
1992 to 2004	Jackaroo/Trooper & Monterey (Isuzu Wagon)	60031	60074	
11/86 to 3/92	Jackaroo/Trooper	60031	*60063 ⁸ / 60009 ⁸ *60064 / 60032	
1982 to 10/86	Jackaroo/Trooper	60031	*60064 / 60032	
99 to 6/2003	Frontera Wagon	60031	N/A	
1995 to 1998	Frontera UT	60031	60074	
HUMMER				
7/2007 on	H3	90001	60045	
HYUNDAI				
To 4/1991	Galoper (Rear Leaf Springs)	60051	*60036 / 60057	
1989 to 5/91	Galoper (Rear Coil Springs) NF & NG	60051	60056	
2001 on	Terracan V6	60040	60060	
2005 on	Terracan Diesel	60040	60060	
LAND ROVER				
1999 to 2004	Discovery Series II (Not Suitable for Airbag Models)	60024	60025 / 60026	OMESD02
1991 to 1999	Discovery Series I	60037	60039 / 60038	OMESD11
To 5/1995	Range Rover (Not Suitable for Airbag Models)	60037	60039 / 60038	OMESD11
1984 on	Defender / County 90 & 110	60037 ^{28,29}	60039 / 60038	OMESD32
	Defender 130	60037 ^{28,29}	60039	OMESD32
	Defender & County 110 & 130 Long Travel	*60070 ^{27,29} / 60018 ^{27,29}	*60070 ²⁷ / 60018 ²⁷	OMESD32
MAZDA				
2011 on	Mazda BT50	*90020 ¹³ / 90019 ¹³	*60101 / 60023 *60102 / 60101	
2006 to 2011	Mazda BT50 All Models	60022 ⁴	*60102 / 60023	
1987 to 2006	B2600 Pick Up All Models	60022 ⁴	60023	
MERCEDES				
	G-Wagon G350 Bluetech / G55 AMG Models	60113	60114	
MITSUBISHI				
2015 on	Pajero Sport All Diesel Models	90008 ¹⁹	*60075 / 60076	
2007 on	Pajero All LWB Models	*90007 ¹³ / 90006 ¹³	60033 / 60019	
2007 on	Pajero All SWB Models	90007 ¹³ / 90006 ¹³	60033 / 60019	
2000 to 10/06	Pajero All LWB Models	*90007 ¹³ / 90006 ¹³	60033 / 60019	
4/00 to 2006	Pajero/Montero NS, NM, NP & NT LWB & SWB	90007 ¹³ / 90006 ¹³	60033 / 60019	
91 to 3/2000	Pajero/Montero (R Coil Springs) NH, NJ, NK, NL (S/LWB)	60040	60041	
	Pajero/Montero (R Leaf Springs) NH, NJ, NK, NL (S/LWB)	60040	*60036 / 60057	
1989 to 5/91	Pajero/Montero Sport (Rear Coil Springs) NF & NG	60051	60056	
To 4/1991	Pajero/Montero (Rear Leaf Springs) NA, NB, NC, ND, NE, NF & NG	60051	*60036 / 60057	
2009 on	Challenger/Montero Sport KH	90008 ¹³	*60075 / 60076	
2000 to 2008	Challenger/Montero Sport (Rear Coil Springs) LWB	60040	60059	
1998 to 2000	Challenger V6/Montero Sport (R Leaf Springs) Wagon PA	60040	*60036 / 60057	
2015 on	Triton/L200 MQ All 4x4 Models	90031 ¹⁹ / 90033 ¹⁹	*60140 ²⁰ / 60139 *60139 / 60138	
7/06 to 2015	Triton/L200 ML & MN All Models	90008 ¹³	60036	
10/96 to 6/06	Triton/L200 MK All Models	60040	60050	
1993 to 9/96	Triton/L200 MJ All Models	60051	60058	
91 to 8/96	Triton/L200 V6 (OE Springs)	60051	60057	
10/86 to 1993	Triton/L200 (V6 & 4 Cylinder) ME, MF, MG, MH	60051	60058	
To 1986	L200 MA, MB, MC & MD	60051	60058	
To 9/1986	L300 Vans SA, SB, SC & SD	60051	60032	
NISSAN				
2010 on	Patrol Y62 (Non HBMC Models)	*90015 ¹¹ / 90014 ¹¹	60084	
1997 on	Patrol Y61 (GU) LWB Off Road Use ONLY ^{31, 32}	60013L	60015L	1/00 on OMESD01 pre 1/00 OMESD11
02/2000 on	Patrol Y61 (GU) SWB & Wagon	60013 / 61012	60015 / 61014 ³	OMESD01
1997 to 1/00	Patrol Y61 (GU) Wagon & SWB	60013 / 61012	60015 / 61014 ³	OMESD11
1997 on	Patrol Y61 (GU) CC (Coil Front/Leaf Spring Rear)	60055	60054	OMESD11
	Patrol Y61 (GU) Cab Chassis (All Coil Springs)	60013 / 61012	60015 / 61014 ³	OMESD11
9/1989 on	Patrol Y60 (GQ) Wagon, SWB & Cab Chassis	60013 / 61012	60015 / 61014	OMESD36
To 8/1989	Patrol Y60 (GQ) Wagon & SWB	60013 / 61012	60015 / 61014	OMESD34

NITROCHARGER SPORT SELECTION

OME NITROCHARGER SPORT SHOCKS & STRUTS

STEERING STABILISERS

YEAR	VEHICLE DESCRIPTION	FRONT	REAR	
NISSAN (continued)				
9/1989 on	Patrol Y60 (GQ) LWB, SWB & CC Suits LPG Conversion	60013 / 61012	61014	OMESD36
To 8/1989	Patrol Y60 (GQ) Wagon & SWB Suits LPG Conversion	60013 / 61012	61014	OMESD34
From 1988	Patrol Y60 (GQ) LWB Off Road Use ONLY ^{31, 32}	60013L	60015L	8/89 on OMESD36 Pre 8/89 OMESD34
1988 to 7/97	Patrol Y60 (GQ) Ute & Cab Chassis (Leaf Springs)	60068	60054	OMESD22
2005 to 2014	Pathfinder R51 (not USA manufactured model)	90003 ¹³	60016	
1986 to 8/95	Pathfinder/Terrano WD21	60031	*60064 / 60032	OMESD35
2005 on	Navara D40 / Frontier (USA)	90003 ¹³	*60110 / 60017	
2015 on	Navara D23 NP300 (Leaf Spring Rear)	90032 ¹³	*60135 / 60134	
	Navara D23 NP300 (Coil Spring Rear)	90032 ¹³	*60137 / 60136	
2008 to 2014	NP300 All Models	60034 ²	60035	
10/2002 on	Navara D22 All Models	60034 ²	60035	
1/86 to 8/02	Navara D21 & D22 Pick Up	60021 ²	60035	OMESD35 ⁶
1/1986 on	Navara D21 & D22 Pick Up 4x2	60040 ²	N/A	
1980 to 1985	720 Ute & Cab Chassis	60040 ²	*60064 / 60032	
1996 to 2005	Terrano II R20	60031 ²	60058	
1996 to 1999	Terrano II 4x4 (European Models)	60031	60058	
2005 on	Xterra	90003 ¹³	60017 ¹⁴	
SSANGYONG				
1995 to 2005	Musso, Sport Utility & Korando Models	60031	N/A	
SUZUKI				
2009 on	Equator (US Market Only)	90003 ¹³	60017	
TOYOTA				
2007 on	LandCruiser 200 Series V8 Not AHC Models	91005 ¹³ / 90017 ¹³	61030 ¹ / 61029 ¹	
3/1998 on	LandCruiser 100 Series (IFS) Not AHC Models	*60001 / 60000	*60003 ¹ / 60002 ¹	
From 04/90	LandCruiser 105 & 80 Series (Front Live Axle)	*60070 / 60018	60071 ¹ / 60020 ¹	OMESD24
	LC 105 & 80 Series (Front Live Axle) LPG conversion	*60070 / 60018	60020 ¹	OMESD24
4/90 to 1998	LandCruiser 80 & 105 Series Off Road Use ONLY ^{31, 32}	60018L / 60070L	60020L / 60071L	OMESD24
	LandCruiser 80 Series	*60070 / 60018	60071 ¹ / 60020 ¹	OMESD24
2009 on	Prado 150 Series LWB (Coil Spring Models Only)	90010 ¹³	*60081 ¹ / 60080 ¹	
	Prado 150 Series SWB (Coil Spring Models Only)	*90010 ¹³ / 90016 ¹³	*60080 ¹ / 60086 ¹	
4/2003 to 09	Prado 120 Series LWB & SWB (Not TEMS/Grande Models)	*90000 ¹³ / 90021 ¹³	*60005 ¹ / 60004 ¹ *60004 ¹ / 60112 ¹	
7/96 to 10/02	Prado 95 & KZJ90 Series	90004	*60027 ¹ / 60028 ¹	
2007 on	LandCruiser 78 & 79 Series SC 6 Cyl. Petrol, Diesel & V8 Diesel Models Not 1GR-FE Models	60008	60011 / 60010 / 60109	OMESD47
1999 to 2006	LandCruiser 78 & 79 Series SC - 6 Cylinder Petrol & Diesel Models Not 1GR-FE Models	60008	60011 / 60010 / 60109	OMESD24
2007 on	LandCruiser 76 Series Wagon - V8	60008	*60111 ¹ / 60011 ¹ / 60010 ¹	OMESD47
1985 to 1999	LandCruiser 75 Series Not 1GR-FE Models	60063 / 60009	60011 / 60010	OMESD24
All	LandCruiser 70 Series Dual Cab Not 1GR-FE Models	60008	60109 / 60010 / 60011	OMESD24 6 Cyl. OMESD47 V8 Dsl.
1985 on	LandCruiser 70, 73 & 74 Series SWB & MWB	60009	60062	OMESD24
To 2007	LandCruiser HZJ71 & HJZ74 Series SWB & MWB	60008	60044	OMESD24
All	LandCruiser II Wagon LWB	60089	60090	
1984 to 1990	Bundera RJ70	60094	60096 RHS 60095 LHS	
1986 to 3/90	LandCruiser 60,61 & 62 Series (Rear Lower Pin 19mm)	60063 / 60009	*60065 / 60062	OMESD24
1980 to 1986	LandCruiser 60 Series (Rear Lower Pin 16mm)	60063 / 60009	*60064 / 60032	OMESD24
All	LandCruiser 45 - 47 Series All LWB Models	60097	60064 / 60032	OMESD23
	LandCruiser 40 - 42 Series SWB	60097	*60064 ²¹ / 60032 ²¹	OMESD23
2010 on	FJ Cruiser	*90010 ¹³ / 90016 ¹³	*60081 ¹ / 60080 ¹ *60080 ¹ / 60086 ¹	
2006 to 2010	FJ Cruiser	*90000 ¹³ / 90021 ¹³	*60004 ¹ / 60112 ¹ 60081 ¹	
2015 on	Fortuner	90028 ¹³ / 90029 ¹³	60141 ²² / 60142 ²²	
2004 to 2015	Fortuner	*90002 ¹³ / 90011 ¹³	60078 / 60077	
2015 on	HiLux All Models	90028 ¹³ / 90029 ¹³	*60133 / 60132	
2005 to 2015	HiLux Vigo KUN26R, GGN25R	*90002 ¹³ / 90011 ¹³	60007 / 60006	

Cont.

NITROCHARGER SPORT SELECTION

OME NITROCHARGER SPORT SHOCKS & STRUTS

STEERING STABILISERS

YEAR	VEHICLE DESCRIPTION	FRONT	REAR	
TOYOTA (continued)				
9/97 to 2004	HiLux Tiger LN172, LN167, KZN165, RZN174 & RZN169 (IFS)	60042	60044 LHS 60043 ⁷ RHS	OMESD33
9/83 to 8/97	HiLux LN65, YN65, LN106 & RN105 (All Leaf Suspension)	60061	*60065 / 60062	OMESD21
To 8/1983	HiLux LN46 & RN46 (All Leaf) (Rear Lower Pin 16mm)	60061	*60064 / 60032	OMESD21
1988 to 8/97	HiLux/4 Runner LN107, RN105, RN110 & LN111 (IFS)	60072	60065	OMESD33
2016 on	Tacoma	*90000 ¹³ / 90021 ¹³	60091	
2005 to 2015	Tacoma V6	*90000 ¹³ / 90021 ¹³	60091	
1998 to 2004	Tacoma V6 & 4 Cylinder Models	90004	*60065 / 60062	
2007 on	Tundra	90018 ¹¹	60100	
2010 on	4 Runner (USA)	90010 ¹³	*60081 ¹ / 60080 ¹	
2003 to 2010	4 Runner (USA)	90000 ¹³	*60005 ¹ / 60004 ¹	
1996 to 2002	4 Runner/Surf Front & Rear Coil Springs (USA)	90004	*60027 / 60028	
1990 to 1996	4 Runner (IFS) Front Torsion Bar/Rear Coil Springs	60072	60073	OMESD33
9/83 to 8/97	4 Runner (All Leaf Suspension)	60061	*60065 / 60062	OMESD21
To 8/1983	4 Runner (All Leaf Suspension) (Rear Lower Pin 16mm)	60061	*60064 / 60032	OMESD21
1986 to 1990	4 Runner (IFS) Rear Leaf Springs	60072	60065	OMESD33
VOLKSWAGEN				
2010 on	Amarok 4 Cylinder Diesel	90013 ^{23,24,30} / 90012 ^{23,24,30}	60083 ²⁵ / 60082 ²⁵	
	Amarok V6 Diesel	90013 ^{23,24,30}	60083 ²⁵ / 60082 ²⁵	

NOTES: *first part number has firmer valving.

- Shock lower body stone guards are recommended fitment to rear shocks to protect against severe stone pepping encountered on loose road surfaces. OME661 (suits Sorento BL To 09, FJ Criser 06 On, 4 Runner 10 On & 03 to 10 USA models, LandCruiser 76 LWB, 80, 100, 105, 200 Series, Prado 150 09 on coil sprung not Kakadu, 120 Series 10/02 to 09 not TEMS & Prado 90 Series to 10/2002 LWB). OME662 (suits LandCruiser 105 & 80 Series with 34mm diameter Control Arm, 100 Series IFS AHC with 40mm diameter Control Arm). OME660 (suits all other models).
- It may be necessary to slightly increase the clearance in the front wishbone to allow the shock absorber to fit. Do not modify the shock absorber.
- FK18 rear sway bar extension bracket for LWB Models and FK24 for SWB Models are **mandatory** fitments with Nitrochargers to prevent damage to sway bar due to increased wheel droop.
- FK22 support brackets must be installed to upper shock mounting brackets on late 1996 on models manufactured in Thailand.
- Original struts and OME coils cannot be used together. No top mounting bushes and dirt shield supplied, re-use OE bushes and dirt shield.
- OMESD35 will suit D21 models only.
- 60043 is 20mm longer and must only be installed to right hand side.
- OMEB11 bush kit is required to convert lower 19mm bush to 16mm ID.
- OMESD40 will only fit left hand drive models.
- FK16 20mm bump stop spacer kit is a **mandatory** fitment.
- No top mounting bushes supplied, re-use OE bushes.
- When remaining stock is exhausted no further product will be available.
- No top mounting bushes supplied, refer to vehicle specific application to select relevant upper strut bushes. OE bushes may be re-used if in good condition.
- FK42 is a **mandatory** fitment to space sway bar link away from shock absorber.
- OME front shock 60121 is not suitable as an OE replacement. When fitting our longer OME shock 60121 you must fit: FK71 brakeline kit to extend/drop the brakelines, FK72 sway bar kit to lower the front swaybar, FK70 radius arm drop bracket kit to 2011 on models, FK80 to 08 - 10 models as if not fitted you may over stretch the front brakelines.
- Re-use rear OE top damper forged bracket, bushes, dirt shield, bumpstops and fasteners for the assembly of the rear shock.
- No top mounting bushes supplied use OME3133 / OME3134 / OME3135, vehicle specific refer to vehicle selection page. OE bushes may be re-used if in good condition. OME struts can only be installed with OME coils.
- 60130 and 60131 **cannot** be used as a shock only OE replacement on Colorado 7/Trailblazer Models. Can be used as an OE replacement for Isuzu MU-X.
- No top mounting bushes supplied use OME3121. OE bushes may be re-used if in good condition. No dirt shield supplied, please re-use OE.
- Shock absorber 60140 is suited for constant rear loading in excess of 800kgs.
- 1975 and newer FJ40's may need to use N76 shocks in rear: Pre 1975 shock eye in the top of the axle housing use N89/N95¹²/60032/60064. Post 1975 lower shock eye is below leaf spring use N76 with OMEB11 Bush Kit.
- FK29 Rear Driveshaft Spacer is a **mandatory** fitment.
- Top mount bump stop and bushes not supplied, re-use OE items.
- For trimming purposes only, maximum 1 packer per strut.
- OME665 Lower Shock Mount Stone Guard is **mandatory** fitment to rear shocks to protect against severe stone pepping encountered on loose road surfaces.
- FK22 Front Shock Absorber Upper Mount Support Bracket Kit is a **mandatory** fitment.
- When fitting 60018 / 60070 it is **mandatory** to fit longer coils 3062 - 3066 for springs to remain trapped with shocks fully extended, fit FK62 to prevent shock damage, fit FK63 for front driveshaft clearance and rear extended travel, fit FK64 which replaces OE upper shock mount when fitting rear shocks and remove any inner helper coils already fitted. **Caution:** Front driveshaft **MUST** be replaced / modified with Double Cardan Joints and checked for Uni bind with OME shocks installed at droop. Cont.

NITROCHARGER SPORT SELECTION

NOTES: - (cont.) - *first part number has firmer valving.

28. Caution: Due to altered gearbox mounts on models after 1998 any lift above OE ride height may cause front driveline vibration that can only be rectified by fitment of front Double Cardan Joints.
29. Caster Kit will increase caster angle by 2°. Check manufacturer's specifications to determine if Caster Kit is required. CALR1 suits 38mm wide control arms. CALR2 suits 44mm wide control arms.
30. Volkswagen Service Manual quotes that driveshaft bolts are a one use only. It is recommended to replace bolts. Replacement bolts Volkswagen Part Number N90991102 are to be sourced separately.
31. Suits 75mm and 100mm coils
32. Vehicle specific, refer to vehicle selection page for full details and to review **important** notification regarding modifications for off road use only along with warranty implications.
JK Wrangler: refer page 31 Patrol GU Y61 & GQ Y60: refer page 66 LandCruiser 80 & 105 Series: refer page 89

REPLACEMENT NITROCHARGER SPORT DIRT SHIELDS	PART NUMBER
Nitrocharger Dust Boot - Black	OME512422
Nitrocharger Dust Boot - Yellow	OME412422
Sports Dirt Shield - Strut	141-032-027
Sports Dust Boot - Black	141-032-028
Hard Sport Dirt Shield 170mm long	384006170
Hard Sport Dirt Shield 210mm long	384006210
Hard Sport Dirt Shield 250mm long	384006250
Hard Sport Dirt Shield 290mm long	384006290

Note: The last 3 numbers of the part number indicates the length of the dirt shield.

NITROCHARGER SPORT L SERIES						
Vehicle	Front	Open (mm)	Closed (mm)	Rear	Open (mm)	Closed (mm)
Jeep JK (Middle Front)	60066L	693	404	60067L	706	422
	60066M	646	382	n/a	n/a	n/a
Jeep XJ	60052L	678	392	60053L	622	366
Jeep TJ	60047L	678	392	60049L	622	366
Patrol Y60, Y61	60013L	555	322	60015L	716	426
LandCruiser 80, 100	60070L	667	381	60071L	673	387
	60018L	667	381	60020L	673	387
Discovery I to 99	60037L	593	349	60039L	600	366
Discovery II to 04	60024L	627	388	60025L	627	388
Defender 90, 110, 130	60037L	593	349	60039L	600	366
Range Rover to 5/95 Non Airbag Models	60037L	593	349	60039L	600	366

Remarks:

Refer to page 157 to 160 of the OME International Application Catalogue for open and closed lengths of equivalent standard Nitrocharger Sport models.

Warranty Implications

The fitter selling these shocks **must** inform the customer there is **no warranty** due to the severe nature of competition racing. The fitter must also note on the customer's receipt "racing application no warranty applies". This will prevent any future misunderstanding.

NITROCHARGERS & STEERING STABILISERS

SHOCK ABSORBER SELECTION ADVICE

Where there is a choice of part numbers it is important the right selection is made with consideration given to type of spring rates and customer applications.

Firm Valving

The firm part number should be selected whenever heavy rate springs are fitted, as the valving has been specifically developed to control the higher spring rates. The firmer valving will provide better control when cornering, while also preventing axle bounce over rough roads.

If a softer valved selection is fitted with a heavy rate spring the vehicle's rebound handling will be reduced. This will be evident by axle bounce over rough roads, dipping under braking or cornering and wallowing over undulating roads.

Soft Valving

Valved specifically for light to medium rate springs. Most suitable for customers wanting a comfortable ride and regularly carry light to medium loads. Under full GVM load a slight amount of body roll during cornering and highway speed manoeuvring can occur.

A CAUTION FOR CUSTOMERS BUYING 4 REPLACEMENT SHOCK ABSORBERS

By the time a customer has decided to replace the old and well used original shock absorbers there is every chance that the original springs are also ready for replacement.

It should be explained to the customer that if their springs are sagged and tired that this would cause the shock absorbers to work a lot harder.

Therefore, the life expectancy of the shock absorbers will be considerably shortened and when loaded ride and handling qualities will also be reduced.

REMEMBER: A good set of shock absorbers will not overcome a bad set of springs.

YEAR	VEHICLE DESCRIPTION	OME NITROCHARGERS, STRUTS & CARTRIDGES		STEERING STABILISERS
		FRONT	REAR	
CHRYSLER JEEP				
2006 to 2010	Comander XK	*N219S/N188S	*N220/N190	
2008 to 2013	Cherokee/Liberty KK ALL Models	NS131 ^{16,18}	N132 ¹⁸	
2002 to 2007	Cherokee/Liberty KJ ALL Models (OME Springs)	*NS131 ^{16,18} /NS130 ^{16,18}	N132 ¹⁸	
2006 to 2010	Grand Cherokee WH & WK	*N219S/N188S ¹⁶	*N220/N190	
1998 to 2005	Grand Cherokee WJ & WG	N111 ¹¹	N117	
1993 to 1998	Grand Cherokee ZJ - 6 cylinder & V8 engines	*N39 ¹⁸	See Sport Selection	OMESD40 ¹⁰
1984 on	Cherokee XJ - Petrol & Diesel	See Sport Selection	See Sport Selection	OMESD40 ¹⁰
To 1986	Cherokee Wagon & J10 Ute (Full Size)	N41 ¹	See Sport Selection	
1974 to 1986	Cherokee W10 & J20 Utes and Cab Chassis	N41 ¹	N43	
To 1986	CJ5, 6, 7, & 8	*N41/N81 ¹	-	
2006 on	Wrangler JK - All Models	See Sport Selection	N198 ¹⁸	OMESD48
1997 to 2006	Wrangler TJ	*N66 ¹⁸ /N66C ¹⁸	N67 ^{5,18}	OMESD40 ¹⁰
1986 to 1996	Wrangler YJ	N33	See Sport Selection	OMESD40 ¹⁰
DAIHATSU				
1992 to 1997	Feroza II F310	N18 ¹⁸	*N49/N96	
1988 to 1992	Feroza I F300	N18 ¹⁸	N43	
1993 on	Rocky F78 Wide Track	-	N33	OMESD31 ¹⁸ '86 on
1984 to 8/93	Rocky F70, F75, F80 & F85 Hard Top with Leaf Springs	OME027	N43	OMESD31 ¹⁸ '86 on
1984 to 1993	Rocky F77 & 78 Tray Top with Leaf Springs	OME027	*N48/N97	
All	Scat Hard Top	N41/N81	*N48/N97	
FORD				
2006 to 2011	Ranger PJ All Models	N194 ¹⁸ /N187 ^{8,18}	See Sport Selection	
1985 to 2005	Courier/Ranger 1 Tonne not USA manufactured model	N51 ^{8,18}	See Sport Selection	
To 2001	Explorer 4x4 Only	N16	N17	
2005 to 2008	Ford F250 & F350	N195	N179	
1999 to 2004	Ford F250 & F350	N178	N179+N180 ⁹	
1987 to 1993	Raider Wagon	N51 ¹⁸	-	
All	Maverick Wagon & Hard Top	*N21 ¹⁸ /N23F ¹⁸	N29	To 8/89 OMESD34 9/89 on OMESD36
	Maverick Ute & Cab Chassis	See Sport Selection	N25	OMESD22
1981 to 1989	Bronco (Single I Beam Front End)	-	N42 ³	
1981 to 1989	Bronco (Dual I Beam Front End)	-	N42 ³	
1981 to 1989	F100 4x4 & 4x2 (Single I Beam)	-	N42 ³	
HOLDEN/SUZUKI/CHEVY				
2008 to 2011	GM/Isuzu Pick up - Colorado RC/DMAX Diesel Models	See Sport Selection	*N42/N89	
	GM/Isuzu Pick up - Colorado V6/DMAX Petrol	See Sport Selection	*N42/N89	

Cont.

NITROCHARGERS & STEERING STABILISERS

OME NITROCHARGERS, STRUTS & CARTRIDGES

STEERING STABILISERS

YEAR	VEHICLE DESCRIPTION	FRONT	REAR	
HOLDEN/ISUZU/CHEVY (continued)				
2003 to 2011	Rodeo Pick Up - RA Models	See Sport Selection	*N42/N89	
2003 to 2008	Rodeo Pick Up - RA & RA7 Models	See Sport Selection	*N42/N89	
7/81 to 2003	Rodeo/Isuzu Pick Up KB4, KBD4 & TFS	See Sport Selection	*N42/N89	
1992 to 2004	Jackaroo/Trooper & Monterey (Isuzu Wagon)	See Sport Selection	See Sport Selection	
11/86 to 3/92	Jackaroo/Trooper	See Sport Selection	*N42/N89	
1982 to 10/86	Jackaroo/Trooper	See Sport Selection	*N42/N89	
99 to 6/2003	Frontera Wagon	See Sport Selection	N102	
1995 to 1998	Frontera 2 & 4 Door UT	See Sport Selection	See Sport Selection	
1985 to 1987	Drover QB (OE Springs)	OME025	-	OMESD30
1985 to 1987	Drover QB (OME Springs Fitted)	OME015	OME013	OMESD30
KIA				
2006 to 2009	Sorento All BL Models	N147S + N148S ¹⁶	N205	
03 to Late 06	Sorento All Models	N147S + N148S ¹⁶	N149	
LAND ROVER				
1999 to 2004	Discovery Series II (Not Suitable for Air Bag Models)	*N107 ¹⁸	N108 ¹⁸	OMESD02
1991 to 1999	Discovery Series I	N45F ¹⁸	See Sport Selection	OMESD11
1994 to 2001	Range Rover MK II P38A Models	N176 ¹⁴	N177 ¹⁴	
To 5/1995	Range Rover (Not Suitable for Air Bag Models)	N45F ¹⁸	See Sport Selection	OMESD11
1984 on	Defender / County 110 & 130	N45F ¹⁸	See Sport Selection	OMESD32
	Defender / County 90	N45F ¹⁸	See Sport Selection	OMESD32
To 1984	Land Rover Series I, II & III (80" & 109")	N78	N69	OMESD11
	Land Rover Series II & III (88" SWB)	N78	N90 ¹⁸	OMESD11
MAHINDRA				
1990 to 1993	Bushranger & Stockman CJ340	*N41/N81 ¹	*N41/N81 ¹	
MAZDA				
06 to 2011	Mazda BT50 All Models	*N194 ¹⁸ /N187 ^{8,18}	See Sport Selection	
1987 to 2006	B2600 Pick Up All Models	N51 ^{8,18}	See Sport Selection	
MITSUBISHI				
2015 on	Pajero Sport All Diesel Models	N186S ¹⁹	N116	
4/2000 on	Pajero/Montero SWB NS, NM, NP & NT (3.2 Diesel)	See Sport Selection	N204 ¹⁸	
	Pajero/Montero SWB NS, NM, NP & NT Wagon & Hard Top (V6)	See Sport Selection	N204 ¹⁸	
1991 to 3/00	Pajero/Montero (Rear Coil Springs) NH, NJ, NK & NL	N18 ¹⁸	N64 ¹⁸	
	Pajero/Montero (Rear Leaf Springs) NH, NJ, NK & NL	N18 ¹⁸	See Sport Selection	
1989 to 5/91	Pajero/Montero (Rear Coil Springs) NF & NG	See Sport Selection	See Sport Selection	
To 4/1991	Pajero/Montero (Rear Leaf Springs) NA, NB, NC, ND, NE, NF & NG	See Sport Selection	See Sport Selection	
2009 on	Challenger/Montero Sport KH	N186S ¹⁹	N116	
2000 to 2008	Challenger/Montero Sport (Rear Coil Springs)	See Sport Selection	N116	
1998 to 2000	Challenger/Montero Sport (Rear Leaf Springs)	See Sport Selection	See Sport Selection	
7/06 to 2015	Triton/L200 ML & MN All Models	N186S ¹⁹	N59	
10/96 to 6/06	Triton/L200 MK All Models	N18 ¹⁸	N30E	
1991 to 8/96	Triton/L200 V6 (OE Springs)	See Sport Selection	N30E	
1991 to 8/96	Triton/L200 (V6) MH & MJ	See Sport Selection	See Sport Selection	
1986 to 8/96	Triton/L200 (4 Cylinder) ME, MF, MG, MH & MJ	See Sport Selection	See Sport Selection	
To 1986	L200 MA, MB, MC & MD	See Sport Selection	See Sport Selection	
To 9/1986	L300 Vans SA, SB, SC & SD	See Sport Selection	N89	
NISSAN				
2/2000 on	Patrol Y61 (GU) SWB & Wagon	*N19/N19C ¹⁸	N29	OMESD01
1997 on	Patrol Y61 (GU) Cab Chassis (Coil Front/Leaf Spring Rear)	*N19/N19C ¹⁸	N25	OMESD11
	Patrol Y61 (GU) Cab Chassis (All Coil Springs)	*N19/N19C ¹⁸	N29	OMESD11
1997 to 1/00	Patrol Y61 (GU) Wagon & SWB	*N19/N19C ¹⁸	N29	OMESD11
9/1989 on	Patrol Y60 (GQ) Wagon & SWB	*N21 ¹⁸ /N23F ¹⁸	*N29/N22F ¹⁸	OMESD36
	Patrol Y60 (GQ) Cab Chassis (Coil Springs)	N21 ¹⁸ /N23F ¹⁸	*N29/N22F ¹⁸	OMESD36
To 8/1989	Patrol Y60 (GQ) Wagon & SWB	*N21 ¹⁸ /N23F ¹⁸	*N29/N22F ¹⁸	OMESD34
1988 to 7/97	Patrol Y60 (GQ) Ute & Cab Chassis (Leaf Springs)	See Sport Selection	N25	OMESD22
All	Patrol MQ 260 LWB Spanish Built 2.8td Models	N19	*N42/N89	
8/83 to 1988	Patrol MQ Wagon, SWB, Ute & Cab Chassis	N49	N48/N97	OMESD22
1980 to 7/83	Patrol MQ Wagon, SWB, Ute & Cab Chassis	*N47/N96	N48/N97	OMESD22
1967 to 1979	Patrol 60 & G60 Series	N49	N49	OMESD22
2005 to 2014	Pathfinder R51	See Sport Selection	See Sport Selection	

Cont.

NITROCHARGERS & STEERING STABILISERS

OME NITROCHARGERS, STRUTS & CARTRIDGES

STEERING STABILISERS

YEAR	VEHICLE DESCRIPTION	FRONT	REAR	
NISSAN (continued)				
2/99 to 2005	Pathfinder R50 V6 Model	N145S+N146S ^{16,21}	N104	
1996 to 1/99	Pathfinder R50 V6 Model	N145S+N146S ^{16,21}	N61	
1986 to 8/95	Pathfinder/Terrano WD21	See Sport Selection	*N42/N89	OMESD35
2005 on	Navara D40	See Sport Selection	N185	
10/2002 on	Navara D22	See Sport Selection	N59	
2008 to 2014	NP300 All Models	See Sport Selection	N59	
1/86 to 8/02	Navara D21 & D22 Pick Up	N58 ^{4,18}	N59	OMESD35 ¹²
1/1986 on	Navara D21 & D22 Pick Up 4x2	N18 ¹⁸	*N41/N81	
1996 to 2005 Terrano II 4x4 (European Models) (OE Springs)		See Sport Selection	See Sport Selection	
2005 on	Xterra	See Sport Selection	N185 ²⁰	
1980 to 1985	720 Ute & Cab Chassis	N18 ¹⁸	*N42/N89	
SSANGYONG				
To 2005	Musso, Sport Utility & Korando Models	See Sport Selection	N118	
SUZUKI				
2009 on	Equator (US Market Only)	See Sport Selection	N185	
2001 to 2005	XL7 Wagon V6	N103S ¹⁷	N105	
8/05 to 2015	Grand Vitara Wagon Models	N217S + N218S	OME036	
1995 to 2005	Grand Vitara petrol 4 & 6 Cylinder & diesel engines	N103S	N105	
7/88 to 2005	Vitara TA01, TD01 & Wagon	N103S	N105	
	Vitara TA012 TD01 SWB	N103S ²²	N32 ²³	
All	Jimny SN413 (OE Springs)	OME028	OME030^{17, 18}	
All	Jimny SN413 (OME Springs)	OME028	OME029	
To 2004	Santana Samurai All Models	OME034	OME035	OMESD30 ¹³
1982 to 1995	Sierra SJ410 & SJ413 Ute MG410 / WT1000cc (OME Springs)	OME015	OME013	OMESD30 ¹³
1988 to 1996	Sierra SJ70, SJ71, SJ413, MG410 / WT1300cc (OME Springs)	OME025	OME013	OMESD30 ¹³
1978 to 12/81 LJ80 & LJ80V SWB (OE Springs)		OME025	-	OMESD30 ^{13,14}
1978 to 12/81	LJ80 & LJ80V SWB (OME Springs)	OME015	N43	OMESD30 ¹³
	LJ80 Ute (OME Springs)	OME015	OME013	OMESD30 ¹³
1974 to 12/81	540, LJ10, LJ20 & LJ50 (OME Springs)	OME015	OME013	OMESD30 ¹³
TOYOTA				
2007 on	LandCruiser 200 Series V8 Not AHC	N208S ⁸	*N210 ¹⁸ /N209	
3/1998 on	LandCruiser 100 Series (IFS) Not AHC	*N199 ¹⁸ /N133/N100 ¹⁸	*N200 ¹⁸ /N101 ¹	
	LandCruiser 100 & 105 Series (Front Live Axle)	N73	N74E	OMESD24
4/90 to 1998	LandCruiser 80 Series	N73	N74E	OMESD24
4/2003 to 09	Prado 120 Series (Except TEMS/Grande Models)	*N201S ^{17,19} / N140S ¹⁹ / N139S ^{13, 17}	N202 ^{2,18} /N141 ²	
7/96 to 10/02	Prado 95 & KZJ90 Series	N91SC ¹⁸	N86 ²	
2007 on	LandCruiser 78 & 79 Series V8 Diesel Model	*N181 ¹⁸ /N106 ¹⁸	See Sport Selection	OMESD47
	LandCruiser 78 & 79 Series 6 Cyl. Petrol & Diesel Models	N181 ¹⁸	See Sport Selection	OMESD47
1999 to 2006	LandCruiser 78 & 79 Series - 6 Cylinder Models	N106 ¹⁸	N75F ¹⁸	OMESD24
2007 on	LandCruiser 76 Series Wagon - V8	*N181 ¹⁸ /N106 ¹⁸	See Sport Selection	OMESD47
1985 to 1999	LandCruiser 75 Series	*N50/N92 ¹⁸	N75F ¹⁸	OMESD24
All	LandCruiser II LJ/RJ70, LJ/KZJ71 & LJ/KZJ78 Models	N77 ¹⁸	N79 ¹⁸	OMESD24
1984 to 1990	LandCruiser Bundera, SWB, LJ70 & RJ70 Series	N114 ¹⁸	N113 ¹⁸ RHS	
All	LandCruiser 70 Series Dual Cab	N181 ¹⁸	See Sport Selection	OMESD24
1985 on	LandCruiser 70,73 & 74 Series SWB & MWB	*N50/N92 ¹⁸	*N85 ¹⁸ /N94 ¹⁸	OMESD24
To 2007	LandCruiser HZJ71 & HJZ74 Series	N106 ¹⁸	See Sport Selection	OMESD24
1986 to 3/90	LandCruiser 60,61 & 62 Series (Rear Lower Pin 19mm)	*N50/N92 ¹⁸	*N90 ¹⁸ /N85 ¹⁸ /N94 ¹⁸	OMESD24
1980 to 1986	LandCruiser 60 Series (Rear Lower Pin 16mm)	*N50/N92 ¹⁸	*N42/N89/N95 ¹⁸	OMESD24
1980 to 1986 LandCruiser 60 Series (OE Springs)		N50	N42	OMESD24
1986 to 3/90 LandCruiser 60 Series (OE Springs)		N50	N90¹⁸/N85¹⁸	OMESD24
To 11/1980	LandCruiser FJ55	N43	N42	
To 12/1984	LandCruiser 45 & 47 Series All LWB Models	*N41/N81	*N42/N89	OMESD23
	LandCruiser BJ, FJ & HJ 40 & 42 Series SWB	*N41/N81	*N89/N95 ^{18,24}	OMESD23
To 12/1984 LandCruiser BJ, FJ & HJ 40 & 42 Series All Models (OE Springs)		N41	N42	OMESD23
2004 To 2015	Fortuner	*N167S ¹⁹ /N166S ¹⁹	N191	
2006 to 2010	FJ Cruiser	N140S ¹⁹	N141 ²	
2005 To 2015	HiLux Vigo KUN26R, GGN25R	*N167S ¹⁹ /N166S ¹⁹	*N169 ¹⁸ /N168	
9/97 to 2004	HiLux Tiger LN172, LN167, KZN 165, RZN174 & RZN169 (IFS)	See Sport Selection	N75 ¹⁸	OMESD33
9/83 to 8/97	HiLux LN65, YN65, LN106 & RN105 (All Leaf Suspension)	See Sport Selection	*N85 ¹⁸ /N94 ¹⁸	OMESD21
To 8/1983	HiLux LN46 & RN46 (All Leaf) (Rear Lower Pin 16mm)	See Sport Selection	*N89/N95 ¹⁸	OMESD21

Cont.

NITROCHARGERS & STEERING STABILISERS

OME NITROCHARGERS, STRUTS & CARTRIDGES

STEERING STABILISERS

YEAR	VEHICLE DESCRIPTION	FRONT	REAR	
TOYOTA (continued)				
To 8/1983	HiLux LN46 & RN46 (All Leaf) (Rear Lower Pin 16mm) (OE Springs)	See Sport Selection	*N42/N89	OMESD21
9/83 to 8/97	HiLux LN65, YN65, LN106 & RN105 (OE Springs)	See Sport Selection	*N90 ¹⁸ /N85 ¹⁸	OMESD21
1988 to 8/97	HiLux/4 Runner LN107, RN105, RN110 & LN111 (IFS)	See Sport Selection	*N85 ¹⁸ /N94 ¹⁸	OMESD33
1988 to 8/97	HiLux/4 Runner LN107, RN105, RN110 & LN111(IFS)(OE Springs)	See Sport Selection	*N90 ¹⁸ /N85 ¹⁸	OMESD33
2003 to 2012	4 Runner (USA)	N140S ¹⁹	N141	
1996 to 2002	4 Runner/Surf Front & Rear Coil Springs (USA)	N91SC ¹⁸	N86	
1990 to 1996	4 Runner (IFS) Front Torsion Bar/Rear Coil Springs	See Sport Selection	N72F ¹⁸	OMESD33
1986 to 1990	4 Runner (IFS) Rear Leaf Springs (OE Springs)	See Sport Selection	N85 ¹⁸ /N94 ¹⁸	OMESD33
1986 to 1990	4 Runner (IFS) Rear Leaf Springs	See Sport Selection	*N85 ¹⁸ /N94 ¹⁸	OMESD33
1984 to 1986	4 Runner (Front Live Axle) (OE Springs)	See Sport Selection	N90 ¹⁸ /N85 ¹⁸	OMESD21
1984 to 1986	4 Runner (Front Live Axle)	See Sport Selection	N85 ¹⁸ /N94 ¹⁸	OMESD21
1982 to 1983	Blizzard	*N41/N81	N48	
1997 to 2003	Kijang (4th Gen.)	N128 ¹⁸	-	
2005 to 2015	Tacoma V6	N140S ¹⁹	N182 ¹⁸	
To 2004	Tacoma V6 & 4 Cylinder Models	N91SC ¹⁸	N85 ¹⁸	
2007 on	Tundra	N192S ¹⁶	N193	
VOLKSWAGEN				
1985 to 1990	Syncro 4x4	N38S	N37	

Remarks:

Refer to page 161 to 164 of the OME International Application Catalogue for open and closed lengths of equivalent standard Nitrocharger models.

NOTES: *first part number has firmer valving.

- 1983 and on wide track CJ Jeeps require bush kit OMEB27 for the front lower mount and all Cherokee wagons and Mahindra lower front and rear mounts.
- Shock lower body stone guards are recommended fitment to rear shocks to protect against severe stone peppering encountered on loose road surfaces. OME661 (suits Sorento BL To 09, FJ Criser 06 On, 4 Runner 10 On, LandCruiser 76 LWB, 200 Series, Prado 150 09 on coil sprung not Kakadu, 120 Series 10/02 to 09 not TEMS & Prado 90 Series to 10/2002 LWB). OME662 (suits LandCruiser 105 & 80 Series with 34mm diameter Control Arm, 100 Series IFS not AHC with 40mm diameter Control Arm). OME660 (all other models).
- 1981 on F100 and Bronco require bush kit OMEB27 on bottom rear mount.
- It may be necessary to slightly increase the clearance in the front wishbone to allow the shock absorber to fit. Do not modify the shock absorber.
- FK16 20mm bump stop spacer kit mandatory fitment.
- FK18 rear sway bar extension bracket for LWB models and FK24 for SWB models are **mandatory** fitment with Nitrochargers to prevent damage to sway bar due to increased wheel droop.
- FK22 support brackets must be installed to upper shock mounting brackets on late 1996 on models manufactured in Thailand.
- N208S can only be installed with OME Coil Springs. No top mounting bushes supplied, re-use OE bushes.
- N179 suits models with single rear shock set up. Models with twin rear shocks require N179 fitment rear of axle, N180 front of axle, also fitment of OME660 stone shields are recommended on the N180.
- OMESD40 will only fit left hand drive models.
- To obtain maximum ride quality improvement it is recommended that an OME replacement stabiliser bar (OMESTAB1) be fitted.
- OMESD35 will suit D21 models only.
- Only suitable for models equipped with original steering damper.
- Shocks are the same length as OE.
- OME030¹⁸ is shorter than OME029 and must be used with OE coils to ensure coils remain entrapped.
- No top mounting bushes supplied, re-use OE bushes.
- FK28 Bump Stop Spacer Kit is a mandatory fitment with N103S Struts.
- When remaining stock is exhausted no further product will be available.
- No top mounting bushes supplied, refer to vehicle specific application to select relevant upper strut bushes. OE bushes may be re-used if in good condition.
- FK42 is a **mandatory** fitment to space sway bar link away from shock absorber.
- Vehicles with ABS will require ABS Bracket Kit SMP638.
- Front strut has 40mm longer travel than original equipment.
- Rear shock has 50mm longer travel than original equipment.
- 1975 and newer FJ40's may need to use N76 shocks in rear: Pre 1975 shock eye in the top of the axle housing use N89/N95¹²/60032/60064. Post 1975 lower shock eye is below leaf spring use N76 with OMEB11 Bush Kit.

**Note: Replacement dust boot part numbers Nitrocharger: OME412422 - Small
Replacement dust boot part numbers Nitrocharger: OME512422 - Large**

COMPACT AWD - OME SPRING & SHOCK ABSORBER

YEAR	VEHICLE DESCRIPTION	LIFT		UNIT PRICE		UNIT PRICE
		F/R (mm)	FRONT	REAR		
DAIHATSU						
97 to 2006	Terios J100 J102	20/20	2531 ¹		No Longer Available	
FORD						
To 06/2006	Escape BA ZA AB	30/30	2904		No Longer Available	
04 to 10/2007	Territory SX SY AWD (4WD)	20/30	2533 ¹		2534 ¹	
GM / OPEL						
2006 on	Captiva, Antara - V6 (3.2) & Diesel	20/30	2529 ¹		2530 ¹	
HONDA						
01/2007 on	CRV	20/20	2535 ¹		2536	
12/01 to 01/07	CRV MY 2002 MY 2005	-/20	CANNOT LIFT		2538	
10/97 to 11/01	CRV RD	30/30	2797		2798	
HYUNDAI						
05/06 to 8/08	Santa Fe CM V6 (2.7) & Diesel	20/30	2527 ¹		2528 ¹	
2000 to 2005	Santa Fe	10/20	2907 ¹		2908 ¹	
KIA						
2005 to 2009	Sportage V6 & Diesel KM Models	20/20	No Longer Available		2526 ¹	
1997 to 2003	Sportage JA MY02 MY03 - V6	20/30	No Longer Available		2524 ¹	
LAND ROVER						
11/00 to 1/04	Freelander V6 & 2Ltr Diesel DOHC - Wagon	10/20	2502 ¹		No Longer Available	
To 10/2000	Freelander 4 Cylinder Petrol Wagon	10/20	2504 ¹		2505 ¹	
	OME Cartridge to Suit OME Springs		No Longer Available		No Longer Available	
	Freelander V6 & 2Ltr Diesel DOHC	10/20	2500 ¹		2501 ¹	
	OME Cartridge to Suit OME Springs		No Longer Available		No Longer Available	
LEXUS						
2003 on	RX-330 4WD MCU38R MY05 - V6	20/30	2509 ¹		2510 ¹	
MAZDA						
To 06/2006	Tribute YU MY03 MY04	30/30	2904		2905 ¹	
NISSAN						
2007 to 2011	X-Trail Petrol	25/25	2511 ¹		2512	
	X-Trail Diesel	25/25	No Longer Available		2512	
01 to 10/2006	X-Trail Petrol	20/20	2506 ¹		No Longer Available	
	X-Trail Diesel	30/30	2507 ¹		Available	
	OME Strut to Suit OME Springs		N213S+N214S		N215S+N216S	
SUBARU						
7/02 to 2005	Forester MY03 MY04 MY05	20/20	No Longer Available		2520 ¹	
9/03 to 2006	Outback 4th Gen MY04 MY05 MY06 4Cyl	20/20	2516 ¹		2518 ¹	
	Outback 4th Gen MY04 MY05 MY06 6Cyl	20/20	2517 ¹		2518 ¹	
TOYOTA						
03 to 04/2007	Kluger / Highlander MCU20R - V6	20/20	2509 ¹		2510 ¹	
01/2006 on	Rav 4 LWB ACA33R - 4 Cylinder	30/30	No Longer Available		2540 ¹	
07/00 to 08/05	Rav 4 SWB & LWB ACA20R ACA21R - Diesel	40/40	No Longer Available		2795	
	Rav 4 SWB & LWB ACA20R ACA21R - Petrol	40/40	2793		2795	
	OME Struts / Gas Shocks to Suit OME Springs		No Longer Available		OME031	
	Rav 4 LWB SXA11R MY98 MY99 - Petrol	25/25	2793		2794	
	OME Struts / Gas Shocks to Suit OME Springs		No Longer Available		OME031	
To 2000	Rav 4 SWB SXA11R MY98 MY99 - Petrol	25/25	2793		No Longer Available	
	OME Struts / Gas Shocks to Suit OME Springs		No Longer Available		OME031	

NOTES:

- When remaining stock is exhausted no further product will be available.

LTR REMOTE CANISTERS

Note: Replacement dust boot part numbers LTR: OME512422 - Large Black
Replacement dust boot part numbers LTR: OME412422 - Small Yellow

GASSING REMOTE CANISTER SHOCK ABSORBERS

The only recommended gas to use in LTR shock absorbers is Nitrogen. A Schrader valve, part number 2755, from Schrader Automotive Inc is required to guarantee correct pressure is reached. When using a Schrader valve to gas your LTR Shock absorber first set the pressure gauge to the required pressure. Attach the Schrader valve to the air fitting at the end of the remote canister. Gas the canister until the shock absorber shaft is fully extended, hold gas pressure for 30 seconds, release Schrader valve and remove.

Note: This can be done for you by your Old Man Emu Stockist.

Important: Gassing of your LTR shock absorber should be carried out before fitment to the vehicle. If LTRs are already fitted the vehicle's suspension should be at full extension before gassing.

MINIMUM/MAXIMUM GAS PRESSURE

On Road/Off Road 40-80psi (2.8 - 5.5 BAR)

Competition 80-100psi (5.5 - 6.9 BAR)

An increase in gas pressure firms up ride quality but will not alter ride height.

MAINTENANCE

The following checks need to be carried out as part of regular vehicle maintenance.

To ensure maximum cooling of your LTR shock absorber inspect the shock absorber body and canister for any mud and debris build up and clean if necessary.

Check that the polyurethane boot is securely fastened in place and that it is not damaged. If the boot is found to be detached thoroughly clean the shock absorber shaft and inside the boot before reattaching it.

Ensure all polyurethane bushes, locating washers and nuts are in good condition and securely fastened.

To ensure maximum shock absorber performance check gas pressure every 20,000km.

ARMoured APPLICATIONS - 4.5T GVM

TOYOTA LANDCRUISER 200 SERIES - 4.5T GVM

FRONT	PART NUMBER	QTY	UNIT PRICE \$	COMMENTS
COILS				
FRONT COILS	2701	1		
SHOCKS				
NITROCHARGER SPORT	90024	2		
COMPONENTS				
FRONT SWAY BAR	OMESTAB4	1		
STRUT TOP HAT KIT	OMETH003	1		Replaces OE top hat if worn
COIL SPRING TRIM PACKER	OME95PF5			
REAR	PART NUMBER	QTY	UNIT PRICE \$	COMMENTS
COILS				
REAR COILS	3067	1		
SHOCKS				
NITROCHARGER SPORT	60119	2		
COMPONENTS				
REAR SWAY BAR	OMESTAB6	1		
REAR SWAY BAR FITTING KIT	FK75	1		
STONE GUARD KIT	OME661	2		Recommended fitment
COIL SPRING TRIM PACKER	OME80PR10			

NISSAN PATROL Y62 - 4.5T GVM

FRONT	PART NUMBER	QTY	UNIT PRICE \$	COMMENTS
COILS				
FRONT COILS	2978	1		
SHOCKS				
NITROCHARGER SPORT	90025	2		
COMPONENTS				
FRONT SWAY BAR	OMESTAB7	1		
REAR	PART NUMBER	QTY	UNIT PRICE \$	COMMENTS
COILS				
REAR COILS	3069	1		
SHOCKS				
NITROCHARGER SPORT	60120	2		
COMPONENTS				
REAR SWAY BAR	OMESTAB8	1		

NOTES ON ARMoured SUSPENSION SELECTION & FITMENT:

The above suspension systems have been designed and tested to suit a vehicle weight range of 3.9 - 4.5T, for vehicle weights outside this range please contact ARB.

Components have been designed to operate as a complete replacement system, it is not recommended to fit these products individually.

LC200 Armoured Suspension System was designed for and tested on non-KDSS equipped vehicles.

Y62 Armoured Suspension System was designed for and tested on non-HBMC equipped vehicles.

OME661 Lower Shock Stone Guards are recommended fitment for protection against stone damage on LC200.

All fitting kits, components and replacement bushes are included with the above products where required.

JEEP GRAND CHEROKEE WK2 2016 ON

FRONT <i>Estimated Lift: 40mm</i>		V6 PETROL ENGINE			V8 & 3.2L DIESEL ENGINE		
		PART NUMBER	QTY	UNIT PRICE \$	PART NUMBER	QTY	UNIT PRICE \$
SPRING: No Bar		3118			3119		
STRUT - SPORT	LHS	90035 1	1		90035 1	1	
	RHS	90036			90036		
SPRING: Bar		3119			3120		
STRUT - SPORT	LHS	90035 1	1		90035 1	1	
	RHS	90036			90036		
SPRING: Bar / Winch		3120			3121		
STRUT - SPORT	LHS	90035 1	1		90035 1	1	
	RHS	90036			90036		
TRIM PACKER		FK79			FK79		

REAR <i>Estimated Lift: 40mm</i>		ALL MODELS (EXCLUDES TOW PACK OPTION)			TOW PACK 2		
		PART NUMBER	QTY	UNIT PRICE \$	PART NUMBER	QTY	UNIT PRICE \$
SPRING: MEDIUM LOAD		3074	1		3074	1	
NITROCHARGER SPORT		60124 1	2		60126 1	2	
SPRING: CONSTANT 200 KGS		3060	1		3060	1	
NITROCHARGER SPORT		60125 1	2		60127 1	2	

REMARKS:

1 No top mounting bushes and dirt shield supplied, re-use OE bushes and dirt shield. Original struts and OME coils cannot be used together.

2 Tow Pack option uses a Nivomat (self leveling) shock absorber and requires a specific design.

Please note: when replacing Nivomat shocks, you **must** fit the appropriate OME spring.

To identify whether a vehicle has the standard fitment rear shock or Nivomat shock, the outer body diameter will need to be measured:

Standard: 51mm

Nivomat: 63mm

Fitting Time: Due to the complexity of installation allow 4 hours for complete install.

JEEP GRAND CHEROKEE WK2 2011 TO 2015

FRONT <i>Estimated Lift: 40mm</i>	V6 PETROL ENGINE			V8 & 3.2L DIESEL ENGINE		
	PART NUMBER	QTY	UNIT PRICE \$	PART NUMBER	QTY	UNIT PRICE \$
SPRING: No Bar	3118	1		3119	1	
STRUT - SPORT	90026 1	2		90026 1	2	
SPRING: Bar	3119	1		3120	1	
STRUT - SPORT	90026 1	2		90026 1	2	
SPRING: Bar / Winch	3120	1		3121	1	
STRUT - SPORT	90026 1	2		90026 1	2	
TRIM PACKER	FK79			FK79		

REAR <i>Estimated Lift: 40mm</i>	ALL MODELS (EXCLUDES TOW PACK OPTION)			TOW PACK 2		
	PART NUMBER	QTY	UNIT PRICE \$	PART NUMBER	QTY	UNIT PRICE \$
SPRING: MEDIUM LOAD	3074	1		3074	1	
NITROCHARGER SPORT	60124 1	2		60126 1	2	
SPRING: CONSTANT 200 KGS	3060	1		3060	1	
NITROCHARGER SPORT	60125 1	2		60127 1	2	

REMARKS:

- 1** No top mounting bushes and dirt shield supplied, re-use OE bushes and dirt shield. Original struts and OME coils cannot be used together.

- 2** Tow Pack option uses a Nivomat (self leveling) shock absorber and requires a specific design.
Please note: when replacing Nivomat shocks, you **must** fit the appropriate OME spring.
 To identify whether a vehicle has the standard fitment rear shock or Nivomat shock, the outer body diameter will need to be measured:
 Standard: 51mm
 Nivomat: 63mm

Fitting Time: Due to the complexity of installation allow 4 hours for complete install.

JEEP GRAND CHEROKEE WH & WK 2005 TO 2010

FRONT <i>Estimated Lift: 50mm</i>	V8 PETROL & DIESEL		
	PART NUMBER	QTY	UNIT PRICE \$
SPRING: TO 40 KGS	2990	1	
STRUT	*N219S / N188S 1	2	
SPRING: 41 TO 100 KGS	2991	1	
STRUT	*N219S / N188S 1	2	

REAR <i>Estimated Lift: 55mm</i>	ALL MODELS		
	PART NUMBER	QTY	UNIT PRICE \$
SPRING: MEDIUM LOAD	2992	1	
NITROCHARGER	*N220 / N190	2	
SPRING: HEAVY LOAD	2993	1	
NITROCHARGER	*N220 / N190	2	

REMARKS:

- 1** No top mounting bushes supplied, re-use OE bushes.

JEEP GRAND CHEROKEE WJ & WG 1999 TO 2004

FRONT <i>Estimated Lift: 40mm</i>	V6 & V8 PETROL ENGINES			DIESEL ENGINE		
	PART NUMBER	QTY	UNIT PRICE \$	PART NUMBER	QTY	UNIT PRICE \$
SPRING: TO 40 KGS	2935	1		2936	1	
NITROCHARGER SPORT	60087	2		60087	2	
NITROCHARGER	N111			N111		
SPRING: 41 TO 90 KGS	2936	1		2936 2	1	
NITROCHARGER SPORT	60087	2		60087	2	
NITROCHARGER	N111			N111		
TRIM PACKER	OMEWJPF10			OMEWJPF10 2		
STABILISER BAR	OMESTAB1 1	1		- 1	-	

REAR <i>Estimated Lift: 40mm</i>	ALL MODELS		
	PART NUMBER	QTY	UNIT PRICE \$
SPRING: MEDIUM LOAD	2944	1	
NITROCHARGER SPORT	60088	2	
NITROCHARGER	N117		
SPRING: HEAVY LOAD	2945	1	
NITROCHARGER SPORT	60088	2	
NITROCHARGER	N117		
TRIM PACKER	OMEWTJPR10		

REMARKS:

- 1** OMESTAB1 is a lighter rate OME replacement stabiliser bar which is a recommended fitment so maximum ride quality improvement can be obtained. (OMESTAB1 does not suit 2.7 Diesel Models).
- 2** Add 1 only OMEWJPF10 Trim Packer to increase ride height for vehicles with bull bar and winch.

JEEP GRAND CHEROKEE ZJ 1993 TO 1998

FRONT <i>Estimated Lift: 20 - 25mm</i>	6 CYLINDER & V8 ENGINES		
	PART NUMBER	QTY	UNIT PRICE \$
SPRING: TO 40 KGS	2931 1	1	
	2934		
NITROCHARGER SPORT	60092	2	
NITROCHARGER	N39 3		
SPRING: 41 TO 90 KGS	2930 1	1	
	2934		
NITROCHARGER SPORT	60092	2	
NITROCHARGER	N39 3		
STEERING DAMPER	OMESD40 2	1	
COIL PACKER	OMEJGF10		

REAR <i>Estimated Lift: 20 - 25mm</i>	ALL MODELS		
	PART NUMBER	QTY	UNIT PRICE \$
SPRING: MEDIUM LOAD	2940	1	
NITROCHARGER SPORT	60093	2	
SPRING: CONSTANT 100 KGS	2943	1	
NITROCHARGER SPORT	60093	2	
COIL PACKER	OMEJGR10		

REMARKS:

- 1** 2931 and 2930 suit 6 cylinder Models. 2934 suits V8 Models.
- 2** OMESD40 will only fit left hand drive Models.
- 3** When existing stock of N39 is exhausted no further product will be available.

JEEP COMMANDER XK 2006 TO 2010

FRONT <i>Estimated Lift: 50mm</i>	V8 PETROL & DIESEL		
	PART NUMBER	QTY	UNIT PRICE \$
SPRING: TO 40 KGS	2990	1	
STRUT	*N219S / N188S ¹	2	
SPRING: 41 TO 100 KGS	2991	1	
STRUT	*N219S / N188S ¹	2	

REAR <i>Estimated Lift: 55mm</i>	ALL MODELS		
	PART NUMBER	QTY	UNIT PRICE \$
SPRING: LIGHT LOAD	2992	1	
NITROCHARGER	*N220 / N190	2	
SPRING: MEDIUM LOAD	2993	1	
NITROCHARGER	*N220 / N190	2	

REMARKS:

- 1** No top mounting bushes supplied, re-use OE bushes.

JEEP CHEROKEE XJ WAGON 1984 TO 2001

FRONT <i>Estimated Lift: 35 - 45mm</i>	PETROL & DIESEL ENGINES			Warning: XJ Models fitted with a 3 bolt engine exhaust pipe flange, can experience a clearance problem with the tail shaft, when suspension is under full deflection. Fitment of an adjustable front panhard rod or a change to the smaller 2 bolt flange will provide the required clearance.
	PART NUMBER	QTY	UNIT PRICE \$	
SPRING:	2930 ³	1		REMARKS:
NITROCHARGER SPORT	60052	2		
TRIM PACKER	OMEJGF10 ³			
STEERING DAMPER	OMESD40 ⁵	1		

REAR <i>Estimated Lift: 50mm</i>	ALL MODELS			1 OMEU60 suits Dana 35 type differential - Australian Models. OMEU57 suits AMC 8 1/4 type differential.
	PART NUMBER	QTY	UNIT PRICE \$	
SPRING: LIGHT LOAD	CS034RA / B ²	1 + 1		2 Trimming requirement greater than 10mm use A/A fitment. Where near level rake is desired B/B fitment should be used. D22XL extra leaf can be fitted to CS034RA/B and CS035RA/B for heavier constant load carrying ability. NB: Models fitted with OE Up Country Suspension Pack will only be raised by 20mm.
NITROCHARGER SPORT	60053	2		
SPRING: MEDIUM LOAD	CS035RA / B ²	1 + 1		3 OMEJGF10 front coil packer can be used for trimming or extra lift purposes, using no more than 1 packer.
NITROCHARGER SPORT	60053	2		
SPRING BUSH KIT	OE			4 Fit XJGK01 Gearbox Packer Kit should a driveline vibration occur.
U BOLTS	OMEU60 ¹ OMEU57	4		
GEARBOX PACKER KIT	XJGK01 ⁴	1		5 OMESD40 will only fit left hand drive Models.
EXTRA LEAF	D22XL	2		
CENTRE BOLT	UCB8			

JEEP CHEROKEE/LIBERTY KK 2008 TO 2013

FRONT <i>Estimated Lift: 30 - 40mm</i> ¹	V6 3.7L PETROL ENGINE			2.8 CRD DIESEL ENGINE		
	PART NUMBER	QTY	UNIT PRICE \$	PART NUMBER	QTY	UNIT PRICE \$
SPRING: TO 50 KGS	2926	1		2927	1	
STRUT - SPORT	90009 ²	2		90009 ²	2	
SPRING: 51 TO 100 KGS	2927	1		2790	1	
STRUT - SPORT	90009 ²	2		90009 ²	2	

REAR <i>Estimated Lift: 40mm</i>	ALL MODELS		
	PART NUMBER	QTY	UNIT PRICE \$
SPRING: MEDIUM LOAD	2730	1	
NITROCHARGER SPORT	60069	2	
NITROCHARGER	N132 ³		
SPRING: CONSTANT 100 KGS	2731	1	
NITROCHARGER SPORT	60069	2	
NITROCHARGER	N132 ³		

REMARKS:

- ¹ Due to varying OE ride heights, some KK Models may only achieve a 20mm lift.
- ² No top mounting bushes supplied, re-use OE bushes.
- ³ When existing stock of NS131 and N132 is exhausted no further product will be available.

JEEP CHEROKEE/LIBERTY KJ 2002 TO 2007

FRONT <i>Estimated Lift: 30 - 40mm</i> ¹	PETROL ENGINE			DIESEL ENGINE		
	PART NUMBER	QTY	UNIT PRICE \$	PART NUMBER	QTY	UNIT PRICE \$
SPRING: NO ACCESSORIES	2925	1		2926	1	
STRUT - SPORT	90009 ²	2		90009 ²	2	
STRUT	NS130 ³			NS130 ³		
SPRING: TO 50 KGS	2926	1		2927	1	
STRUT - SPORT	90009 ²	2		90009 ²	2	
SPRING: 51 TO 100 KGS	2927	1		2790	1	
STRUT - SPORT	90009 ²	2		90009 ²	2	

REAR <i>Estimated Lift: 40mm</i>	ALL MODELS		
	PART NUMBER	QTY	UNIT PRICE \$
SPRING: LIGHT LOAD	2947	1	
NITROCHARGER SPORT	60069	2	
NITROCHARGER	N132 ³		
SPRING: MEDIUM LOAD	2948	1	
NITROCHARGER SPORT	60069	2	
NITROCHARGER	N132 ³		

REMARKS:

- ¹ Due to varying OE ride heights, some KJ Models may only achieve a 20mm lift.
- ² No top mounting bushes supplied, re-use OE bushes.
- ³ When existing stock of NS130, NS131 and N132 is exhausted no further product will be available.

JEEP WRANGLER TJ & TJ UNLIMITED 1997 TO 2006

FRONT <i>Estimated Lift: 50mm</i>	6 CYLINDER ENGINE		
	PART NUMBER	QTY	UNIT PRICE \$
SPRING: TO 40 KGS	2932 1	1	
NITROCHARGER SPORT	*60047 / 60046 6	2	
NITROCHARGER	N66 7		
SPRING: 41 TO 80 KGS	2933 1	1	
NITROCHARGER SPORT	*60047 / 60046 6	2	
NITROCHARGER	N66 7		
TRIM PACKER	OMEJGF10		
STEERING DAMPER	OMESD40 5	1	

REAR <i>Estimated Lift: 50mm</i>	2 DOOR			4 DOOR		
	PART NUMBER	QTY	UNIT PRICE \$	PART NUMBER	QTY	UNIT PRICE \$
SPRING: SOFT TOP	2941 1	1		2949 6	1	
NITROCHARGER SPORT	60048	2		60049	2	
NITROCHARGER	N67 7			N67 7		
SPRING: HARD TOP	2941 1	1		2949 6	1	
NITROCHARGER SPORT	60048	2		60049	2	
NITROCHARGER	N67 7			N67 7		
SPRING: CONSTANT 100 KGS	2942 1	1		-		
NITROCHARGER SPORT	60048	2		-		
NITROCHARGER	N67 7			-		
SPRING: CONSTANT 200 KGS	2949 6	1		2996	1	
NITROCHARGER SPORT	60049	2		60049	2	
NITROCHARGER	N67 7			N67 7		
PANHARD ROD BRACKET KIT	FKWTJ01 2	1		FKWTJ01 2	1	
	FKWTJ02		FKWTJ02			
TRIM PACKER	OMEWTJPR10			OMEWTJPR10		
GEARBOX PACKER KIT	JWGK01 3	1		JWGK01 3	1	
	JWGK02 3		JWGK02 3			
	JWGK03 3		JWGK03 3			
BUMPER STOP SPACER KIT	FK16 4			FK16 4		

REMARKS:

- 1** For ride height and trim adjustment use - Front: OMEJGF10 Rear: OMEWTJPR10
- 2** FKWTJ01 Panhard Rod Extension Bracket Kit fitment to right hand drive or FKWTJ02 to left hand drive Models is **mandatory** to ensure correct rear axle tracking.
- 3** A Gear Box Packer Kit is **mandatory** fitment to prevent driveline vibration.
JWGK01 suits all Models to 2003.
JWGK02 suits manual Models from 2003.
JWGK03 suits auto Models from 2003.
- 4** FK16: **Mandatory** fitment 20mm Bump Stop Spacer Kit to prevent coil springs becoming solid on full compression.
- 5** OMESD40 only suitable for fitment to left hand drive Models.
- 6** To achieve optimal vehicle balance front to rear when Rear Spring 2949 is fitted, it is recommended that only 60047 is fitted to the front.
- 7** When existing stock of N66, N66C and N67 is exhausted no further product will be available.

JEEP WRANGLER YJ 1986 TO 1996

FRONT <i>Estimated Lift: 40 - 50mm</i>	PETROL ENGINE		
	PART NUMBER	QTY	UNIT PRICE \$
SPRING: TO 35 KGS: 50mm	CS014F 4	2	
NITROCHARGER SPORT	60098		
NITROCHARGER	N33		
SPRING: TO 95 KGS: 40mm	CS014F 4	2	
NITROCHARGER SPORT	60098		
NITROCHARGER	N33		
SPRING BUSH KIT	OMESB57 2	2	
	OMESB87		
GEAR BOX PACKER KIT	JWGK01 1	1	
GREASABLE SHACKLE KIT	OMECS11 2		
STEERING DAMPER	OMESD40 3		
EXTRA LEAF	D23XL		
CENTRE BOLT	UCB09	2	

REAR <i>Estimated Lift: 50mm</i>	ALL MODELS		
	PART NUMBER	QTY	UNIT PRICE \$
SPRING: HARD TOP MEDIUM LOAD TO 200 KGS	CS036R 4	2	
NITROCHARGER SPORT	60099		
SPRING: SOFT TOP LIGHT LOAD	CS037R 4	2	
NITROCHARGER SPORT	60099		
SPRING BUSH KIT	OMESB57 2	2	
	OMESB87		
GREASABLE SHACKLE KIT	OMECS11 2	1	
EXTRA LEAF	D24XL	2	
CENTRE BOLT	UCB09		

REMARKS:

- 1** JWGK01 fitment reduces driveline vibration.
- 2** Use OMESB57 with original shackles. OMESB87 with OMECS11 greasable shackles.
- 3** OMESD40 will only fit left hand drive Models.
- 4** Please re-use original U-Bolts.

JEEP WRANGLER JK 2 DOOR 2006 ON

FRONT <i>Estimated Lift: 50mm</i>	V6 PETROL ENGINE			2.8 DIESEL ENGINE		
	PART NUMBER	QTY	UNIT PRICE \$	PART NUMBER	QTY	UNIT PRICE \$
SPRING: NO BAR	2626 ¹	1		2627 ¹	1	
SPRING: BAR	2615			2616		
SPRING: BAR AND WINCH	2627 ¹	1		2628 ¹	1	
NITROCHARGER SPORT	60066	2		60066	2	
STEERING DAMPER	OMESD48	1		OMESD48 ³	1	
STEERING STABILISER MOUNT KIT - LHD	FK50			FK50		
TRIM PACKER	OMEJKPF10			OMEJKPF10		
CASTER CORRECTION KIT	FK53 ⁶	1		FK53 ⁶	1	
BP-51 SELECTION						
SHOCK WRANGLER JK FRONT 2"	BP5160031	2		BP5160031	2	
BP KIT WRANGLER JK FRONT +2"/+4 "	VM80010014	1		VM80010014	1	
REAR <i>Estimated Lift: 50mm</i>	ALL MODELS					
	PART NUMBER	QTY	UNIT PRICE \$			
SPRING: MEDIUM LOAD	2630 ¹	1				
SPRING: CONSTANT 150 KGS	2617	1				
NITROCHARGER SPORT	60067	2				
NITROCHARGER	N198 ⁷					
PANHARD ROD EXTENSION BKT KIT - LHD	FK37	1				
PANHARD ROD EXTENSION BKT KIT - RHD	FK39					
TRIM PACKER	OMEJKPR10					
BP-51 SELECTION						
SHOCK WRANGLER JK REAR 2"	BP5160032	2				
BP KIT WRANGLER JK REAR 2"	VM80010024	1				
SUSPENSION KIT <i>Estimated Lift: 100mm</i>	PETROL ENGINE RHD MODELS ⁴			PETROL ENGINE LHD MODELS ⁴		
	PART NUMBER	QTY	UNIT PRICE \$	PART NUMBER	QTY	UNIT PRICE \$
4" COMPLETE LIFT KIT	OMEJK4RHD ⁵	1		OMEJK4 ⁵	1	
<i>Estimated Lift: 100mm</i>	DIESEL ENGINE RHD MODELS ⁴			DIESEL ENGINE LHD MODELS ⁴		
	4" COMPLETE LIFT KIT	OMEJK4RHDD ⁵	1		OMEJK4D ⁵	1

REMARKS:

- 1** For trim adjustment use - Front: OMEJKPF10 Rear: OMEJKPR10. Do not fit more than 1 packer per coil spring.
- 2** Fitment of Panhard Rod Extension Bracket Kit is not mandatory, but fitment will improve the ride feel by locating the panhard rod to its original position.
- 3** FK50 is a mandatory fitment for 2006 To 2008 Models when fitting OMESD48. Left hand drive only.
- 4** 2012 Models with 3.6L engine will require exhaust or driveshaft modification to avoid contact of driveshaft and exhaust at full droop. When fitting larger than original diameter tyres, it is a requirement to fit aftermarket wheels (rims) that have a greater offset (less backspacing) to ensure that sufficient clearance is given between the tyre to sway bar, sway bar links and control arms.
- 5** Kit includes: 2 x Front Shocks, 2 x Rear Shocks, 1 x (pair) Front Coils, 1 x (pair) Rear Coils, 1 x Steering Damper, 1 x Front Forged Panhard, 1 x Bump Stop Kit, 1 x Brakeline Relocation Kit, 1 x Rear Panhard Bracket Kit, 1 x Sway Bar Link Dis-connect Kit, 1 x Caster & Driveline Kit, 1 x Steering Damper Relocation Kit for LHD Models (not applicable for RHD Models), 2 x Front Trim Packer, 2 x Rear Trim Packer, 1 x Display Carton.
See page 31 for kit breakdown.
- 6** FK53 Caster Kit will increase caster angle by 2°. Check manufacturer's specification if Caster Kit is required.
- 7** When existing stock of N198 is exhausted no further product will be available.

JEEP WRANGLER JK 4 DOOR 2006 ON

FRONT <i>Estimated Lift: 50mm</i>	V6 PETROL ENGINE			2.8 DIESEL ENGINE		
	PART NUMBER	QTY	UNIT PRICE \$	PART NUMBER	QTY	UNIT PRICE \$
SPRING: NO BAR	2627 1	1		2628 1	1	
SPRING: BAR	2616			2619		
SPRING: BAR AND WINCH	2628 1	1		2629 1	1	
NITROCHARGER SPORT	60066	2		60066	2	
STEERING DAMPER	OMESD48 3	1		OMESD48 3	1	
STEERING STABILIZER MOUNT KIT - LHD	FK50			FK50		
TRIM PACKER	OMEJKPF10			OMEJKPF10		
CASTER CORRECTION KIT	FK53 6	1		FK53 6	1	
BP-51 SELECTION						
SHOCK WRANGLER JK FRONT 2"	BP5160031	2		BP5160031	2	
BP KIT WRANGLER JK FRONT +2"/+4 "	VM80010014	1		VM80010014	1	

REAR <i>Estimated Lift: 50mm</i>	ALL MODELS		
	PART NUMBER	QTY	UNIT PRICE \$
SPRING: MEDIUM LOAD	2617 1	1	
SPRING: CONSTANT 150KGS	2618		
SPRING: CONSTANT 300KGS	2620 1	1	
NITROCHARGER SPORT	60067		
NITROCHARGER	N198 7	2	
PANHARD ROD EXTENSION BKT KIT - LHD	FK37 2	1	
PANHARD ROD EXTENSION BKT KIT - RHD	FK39		
TRIM PACKER	OMEJKPR10		
BP-51 SELECTION			
SHOCK WRANGLER JK REAR 2"	BP5160032	2	
BP KIT WRANGLER JK REAR 2"	VM80010024	1	

SUSPENSION KIT <i>Estimated Lift: 100mm</i>	PETROL ENGINE RHD MODELS 4			PETROL ENGINE LHD MODELS 4		
	PART NUMBER	QTY	UNIT PRICE \$	PART NUMBER	QTY	UNIT PRICE \$
4" COMPLETE LIFT KIT	OMEJK4RHD 5	1		OMEJK4 5	1	
<i>Estimated Lift: 100mm</i>	DIESEL ENGINE RHD MODELS 4			DIESEL ENGINE LHD MODELS 4		
4" COMPLETE LIFT KIT	OMEJK4RHDD 5	1		OMEJK4D 5	1	

REMARKS:

- 1 For trim adjustment use - Front: OMEJKPF10 Rear: OMEJKPR10 Do not fit more than 1 packer per coil spring.
- 2 Fitment of Panhard Rod Extension Bracket Kit is not mandatory, but fitment will improve the ride feel by locating the panhard rod to its original position.
- 3 FK50 is a **mandatory** fitment for 2006 To 2008 Models when fitting OMESD48. Left hand drive only.
- 4 2012 Models with 3.6L engine will require exhaust or driveshaft modification to avoid contact of driveshaft and exhaust at full droop. When fitting larger than original diameter tyres, it is a requirement to fit aftermarket wheels (rims) that have a greater offset (less backspacing) to ensure that sufficient clearance is given between the tyre to sway bar, sway bar links and control arms.
- 5 Kit includes: 2 x Front Shocks, 2 x Rear Shocks, 1 x (pair) Front Coils, 1 x (pair) Rear Coils, 1 x Steering Damper, 1 x Front Forged Panhard, 1 x Bump Stop Kit, 1 x Brakeline Relocation Kit, 1 x Rear Panhard Bracket Kit, 1 x Sway Bar Link Dis-connect Kit, 1 x Caster & Driveline Kit, 1 x Steering Damper Relocation Kit for LHD Models (not applicable for RHD Models), 2 x Front Trim Packer, 2 x Rear Trim Packer, 1 x Display Carton.
See page 31 for kit breakdown.
- 6 FK53 Caster Kit will increase caster angel by 2°. Check manufacturer's specification if Caster Kit is required.
- 7 When existing stock of N198 is exhausted no further product will be available.

OFF ROAD USE ONLY - CHRYSLER

JEEP WRANGLER JK

COMPLETE KIT	PART NUMBER	QTY	UNIT PRICE \$	COMMENTS
100mm (4 Inch) LIFT KIT	OMEJK4RHD	1		PETROL ENGINE RHD MODELS
100mm (4 Inch) LIFT KIT	OMEJK4			PETROL ENGINE LHD MODELS
100mm (4 Inch) LIFT KIT	OMEJK4RHDD			DIESEL ENGINE RHD MODELS
100mm (4 Inch) LIFT KIT	OMEJK4D			DIESEL ENGINE LHD MODELS

KIT INCLUDES:

2 x Front Shocks, 2 x Rear Shocks, 1 x (pair) Front Coils, 1 x (pair) Rear Coils, 1 x Steering Damper, 1 x Front Forged Panhard, 1 x Bump Stop Kit, 1 x Brakeline Relocation Kit, 1 x Rear Panhard Bracket Kit, 1 x Sway Bar Link Dis-Connect Kit, 1 x Caster & Driveline Kit, 2 x Front Trim Packer, 2 x Rear Trim Packer, 1 x Display Carton.

FRONT	PART NUMBER	QTY	UNIT PRICE \$	COMMENTS
COILS				
100mm LIFT - PETROL	2642	1		
100mm LIFT - DIESEL	3047			
SHOCKS				
NITROCHARGER SPORT - MID LENGTH	60066M	2		
NITROCHARGER SPORT - LONG	60066L			
BP-51 SELECTION				
SHOCK: JEEP 4+ FRONT 633	BP5160021	2		Suitable for OMEJK4 Kits
SHOCK: JEEP 4+ FRONT 683	BP5160022			Longer travel front shock (other modifications required)
KIT: JEEP 4+ FRONT	VM80010014	1		
STEERING DAMPER				
STABILISER	OMESD48	1		
COMPONENTS				
CASTER KIT	FK53	1		Front caster only, increases caster by 2°
CASTER & DRIVELINE KIT	FK49			Adjust front caster and rear pinion angle
BRAKELINE RELOCATION KIT (F&R)	FK46			
SWAY BAR LINK DIS-CONNECT KIT (F&R)	FK48			Suits 100mm lift
FRONT SWAY BAR LINK	3460010	2		Link only, suits 100mm lift
SWAY BAR LINK BUSH SET	OMESB3023			Suits Front Sway Bar Link 3460010
FRONT LOWER CONTROL ARM	LCAJKFR	1		Suits SWB and Unlimited Models (1 pair)
FRONT UPPER CONTROL ARM	UCAJKFR			Suits SWB and Unlimited Models (1 pair)
ADJUSTABLE FRONT PANHARD ROD	PANRJK002			LHD, Fabricated, suits LHD only
	PANRJK003			RHD
BUMP STOP EXTENSION KIT (F&R)	FK40			
TRIM PACKER	OMEJKPF10			10mm

REAR	PART NUMBER	QTY	UNIT PRICE \$	COMMENTS
COILS				
100mm LIFT - MEDIUM	2643	1		
100mm LIFT - CONSTANT 300KG	3046			
SHOCKS				
NITROCHARGER SPORT - LONG	60067L	2		
BP-51 SELECTION				
SHOCK: JEEP 4+ REAR 685	BP5160030	2		
KIT: JEEP 4+ REAR	VM80010015	1		
COMPONENTS				
REAR PANHARD BRACKET KIT	FK47	1		LHD, suits 100mm lift
	FK47RHD			RHD, suits 100mm lift
REAR SWAY BAR LINK	3460011	2		Link only, suits 100mm lift
REAR LOWER CONTROL ARM	LCAJKRR	1		Suits SWB & Unlimited Models (1 pair)
REAR UPPER CONTROL ARM	UCAJKRR			Suits SWB & Unlimited Models (1 pair)
TRIM PACKER	OMEJKPR10			

Notification: Modifications for off - road use only

The products listed in this selection chart are deemed by Old Man Emu to be suitable for off road use and their legality for public road use should be certified by the relevant Registration Authority. An Off Road Use Only Disclaimer must be signed by the customer.

Modifications and replacement of other associated components will be required.

Lift increase is approximate and will depend on vehicle weights.

Warranty Implications

The fitter selling these shocks **must** inform the customer there is **no warranty** due to the severe nature of competition racing. The fitter must also note on the customer's receipt "racing application no warranty applies". This will prevent any future misunderstanding.

2012 Models with 3.6L engine will require exhaust or driveshaft modification to avoid contact of driveshaft and exhaust at full droop.

When fitting larger than original diameter tyres, it is a requirement to fit aftermarket wheels (rims) that have a greater offset (less backspacing) to ensure that sufficient clearance is given between the tyre to sway bar, sway bar links and control arms.

RANGER PX 2011 ON⁹

FRONT <i>Estimated Lift: 50mm</i>	DIESEL ENGINE		
	PART NUMBER	QTY	UNIT PRICE \$
SPRING: No Bar	2997	1	
STRUT SPORT	90019 1	2	
SPRING: Bar	2998	1	
STRUT SPORT	*90020 / 90019 1	2	
SPRING: Bar / Winch	2999	1	
STRUT SPORT	90020 1	2	
SPRING: No Bar: 30mm LIFT	3048	1	
STRUT SPORT	90019 1	2	
BP-51 SELECTION: Estimated Lift: 30 - 40mm			
BP-51 COIL OVER FRONT RH	BP5190005R	1	
BP-51 COIL OVER FRONT LH	BP5190005L		
BP FIT KIT FRONT	VM80010011		
TRIM PACKER	FK56 2		
UPPER STRUT BUSHES	OME3135 1	2	
STRUT TOP HAT KIT	OMETH006 7		
REAR <i>Estimated Lift: 50mm</i>	ALL MODELS		
	PART NUMBER	QTY	UNIT PRICE \$
SPRING: MEDIUM LOAD	EL049R 4	2	
NITROCHARGER SPORT	*60101 / 60023		
SPRING: CONSTANT 300 KGS	EL068R 4	2	
NITROCHARGER SPORT	*60102 / 60101		
SPRING: CONSTANT 600 KGS	EL069R 4	2	
NITROCHARGER SPORT	60102		
BP-51 SELECTION			
BP-51 SHOCK REAR RH	BP5160027R	1	
BP-51 SHOCK REAR LH	BP5160027L		
BP FIT KIT REAR	VM80010012		
GREASABLE SHACKLE KIT	OMEGS20	1	
SPRING BUSH KIT	OMESB102 3	2	
	OMESB103		
U BOLTS	OMEU66 4	4	
	OMEU66A 4		
	OMEU66B 4		
DRIVELINE SPACER KIT	FK57 5 8	1	
EXTRA LEAF	EL34XL 6	2	

⁹ Important: Please refer to TSB003.

REMARKS:

- 1** No top mounting bushes supplied, use OME3135. OE bushes may be re-used if in good condition.
- 2** Trim Packer FK56 provides 10mm lift at the wheel.
- 3** OMESB102 suits OE Shackle.
OMESB103 Bush Kit suits OME Greasable Shackle OMEGS20.
- 4** Use OMEU66 when fitting EL049R.
Use OMEU66A when fitting EL068R and EL069R.
Use OMEU66B when fitting EL069R with EL34XL.
- 5** Fitment of Driveline Spacer Kit FK57 is recommended to re-align driveline.
- 6** EL34XL will give approximately 30mm extra lift or increase loading capacity at design height by approximately 300kg.
- 7** Strut Top Hat Kit may be required if original equipment is worn.
- 8** If a TAD102 Frontier tank is installed in the vehicle, when fitting the FK57 spacer kit, the tank will need to be lowered to allow removal of the centre bearing bolts.

RANGER PJ/PK 12/2006 TO 2011 ALL MODELS

(NOT USA MANUFACTURED MODEL)

FRONT	PETROL & DIESEL ENGINES		
	PART NUMBER	QTY	UNIT PRICE \$
TORSION BARS: OVER 60 KGS	303013 ⁴	1	
TORSION BARS	303005		
NITROCHARGER SPORT	60022 ¹	2	
NITROCHARGER	N194 ⁵		
FITTING KIT	FK22 ¹	1	

REAR <i>Estimated Lift: 20mm</i>	ALL MODELS		
	PART NUMBER	QTY	UNIT PRICE \$
SPRING: MEDIUM LOAD	CS056R ^{2 3 6}	2	
NITROCHARGER SPORT	60023		
SPRING: CONSTANT 200 KGS	EL049R ^{2 3 6}	2	
NITROCHARGER SPORT	60023		
SPRING: CONSTANT 400 KGS	CS060R ^{2 3 6}	2	
NITROCHARGER SPORT	*60102 / 60023		
GREASABLE SHACKLE KIT	OMEGS18	1	
U BOLTS	OMEU66 ³	4	
	OMEU66A		
SPRING BUSH KIT	OMESB97		
EXTRA LEAF	D34XL / EL34XL ⁶	2	
CENTRE BOLT	UCB19		

REMARKS:

Note: Some South American Models, built in Argentina, use torsion bars with hexagonal ends. Above OME suspension is not suitable for these Models.

1 FK22 Front Shock Absorber Upper Mount Support Bracket Kit is a **mandatory** fitment.

2 Include tray weight in constant load calculation.

3 Use OMEU66 when fitting CS056R and EL049R. Use OMEU66A when fitting CS060R.

4 For Models with 2.5TD engine measure length of Torsion Bar to determine correct fitment.

303005 - 925mm.
303013 - 1024mm.

5 When remaining stock of N187 and N194 is exhausted no further product will be available.

6 D34XL and UCB19 suits CS056R and CS060R.

EL34XL suits EL049R.

COURIER/RANGER 1 TONNE

1985 TO 2005 ALL MODELS (NOT USA MANUFACTURED MODEL)

FRONT	PETROL & DIESEL ENGINES		
	PART NUMBER	QTY	UNIT PRICE \$
TORSION BARS: OVER 60 KGS	303005	1	
NITROCHARGER SPORT	60022 ¹	2	
NITROCHARGER	N51 ³		
FITTING KIT	FK22 ¹	1	

REAR <i>Estimated Lift: 20mm</i>	ALL MODELS		
	PART NUMBER	QTY	UNIT PRICE \$
SPRING: MEDIUM LOAD	CS026R ²	2	
NITROCHARGER SPORT	60023		
SPRING: CONSTANT 200 KGS	CS027R ²	2	
NITROCHARGER SPORT	60023		
U BOLTS	OMEU65	4	
GREASABLE SHACKLE KIT	OMEGS18	1	
SPRING BUSH KIT	OMESB82		
EXTRA LEAF	D9XL	2	
CENTRE BOLT	UCB17		

REMARKS:

1 FK22 Support Brackets **must** be installed to upper front shock mounting brackets on late 1996 On Models manufactured in Thailand.

2 Include tray weight in constant load calculation.

3 When remaining stock of N51 is exhausted no further product will be available.

EVEREST 2015 ON

FRONT <i>Estimated Lift: 40mm</i>	DIESEL ENGINE		
	PART NUMBER	QTY	UNIT PRICE \$
SPRING: No Bar	3048	1	
STRUT SPORT	90019 [1]	2	
SPRING: Bar	2997	1	
STRUT SPORT	*90020 / 90019 [1]	2	
SPRING: Bar / Winch	2998	1	
STRUT SPORT	90020 [1]	2	
TRIM PACKER	FK56 [2]		
UPPER STRUT BUSHES	OME3135 [1]	2	
STRUT TOP HAT KIT	OMETH006 [3]		

REAR <i>Estimated Lift: 40mm</i>	ALL MODELS		
	PART NUMBER	QTY	UNIT PRICE \$
SPRING: MEDIUM LOAD	3106	1	
NITROCHARGER SPORT	60144 [4]	2	
SPRING: CONSTANT 300 KGS	3107	1	
NITROCHARGER SPORT	*60145 / 60144 [4]	2	

REMARKS:

- 1** No top mounting bushes supplied, use OME3135. OE bushes may be re-used if in good condition.
- 2** Trim Packer FK56 provides 10mm lift at the wheel.
- 3** Strut Top Hat Kit may be required if original equipment is worn. This kit includes rubber bushing.
- 4** Re-use rear OE top damper forged bracket, bushes, dirt shield, bumpstops and fasteners for the assembly of the rear shock.

FORD EXPLORER 1996 TO 2001 REAR LEAF SPRING MODELS

FRONT	V6 PETROL ENGINE		
	PART NUMBER	QTY	UNIT PRICE \$
TORSION BARS	-	1	
NITROCHARGER	N16	2	

REAR <i>Estimated Lift: 40mm</i>			
	PART NUMBER	QTY	UNIT PRICE \$
SPRING: MEDIUM LOAD	CS042R	2	
NITROCHARGER	N17	2	
EXTRA LEAF	D10XL	2	
CENTRE BOLT	UCB5		

REMARKS:

1 Raise or lower front end clearance and trim vehicle by adjusting front torsion bars. **Important:** A minimum of 60mm of droop **must** be maintained.

2 OE spring bushes are required to fit CS042R springs. D10XL extra leaf should be fitted when a constant 200kg plus load is carried.

FORD F250 & F350 2011 TO 2017

FRONT <i>Estimated Lift: 45mm (2 inch)</i>	DIESEL ENGINE		
	PART NUMBER	QTY	UNIT PRICE \$
SPRING: 45MM	2768	1	
NITROCHARGER SPORT	60123	2	
CASTER CORRECTION KIT	FK81	1	

REMARKS:

1 When fitting either 3075 or 3076 it is **mandatory** to fit Bump Spacer Kit FK73 to prevent the coil from being over stressed.

2 OME front shock 60121 is not suitable as an OE replacement. When fitting our longer OME shock 60121 you must fit:

- FK71 Brakeline Kit to extend / drop the brakelines
- FK72 Swaybar Kit to lower the front swaybar
- FK70 Radius Arm Drop Bracket Kit, if not fitted you may over stretch the front brakelines

3 When bull bar and / or winch are fitted use FK74 on both coils to restore nominal lift height.

4 Where the OE rear leaf spring has an overload leaf fitted, this overload leaf is to be fitted to the OME leaf, EL077R is to have its centre bolt replaced with a longer bolt UCB21 and OE spacer blocks are to be reused.

FRONT <i>Estimated Lift: 75 - 100mm (3 inch to 4 inch)</i>	DIESEL ENGINE			
	PART NUMBER	QTY	UNIT PRICE \$	
SPRING: 75MM	3075	1		
NITROCHARGER SPORT	60121	2		
SPRING: 100MM	3076	1		
NITROCHARGER SPORT	60121	2		
PANHARD BRACKET	FK69	1		
RADIUS ARM DROP BRACKET KIT	FK70			
BRAKELINE BRACKET KIT	FK71			
SWAYBAR BRACKET KIT	FK72			
BUMP SPACER KIT	FK73			
TRIM PACKET (10mm)	FK74		3	

5 Use OMEU77 when fitting to a vehicle without an overload leaf.

Use OMEU78 when fitting to a vehicle with an overload leaf.

6 Fitment of a FK81 Caster Correction Kit will provide approximately 3.5 to 4.0 degrees of extra caster. It is advisable to have a front end alignment carried out to determine if a FK81 kit is required.

REAR <i>Estimated Lift: 75mm (3 inch)</i>	ALL MODELS		
	PART NUMBER	QTY	UNIT PRICE \$
SPRING: MEDIUM LOAD	EL077R	2	
SPRING: CONSTANT 450 KGS	EL077R + EL40XL	2 + 2	
NITROCHARGER SPORT	60122	2	
SPRING BUSH KIT	OMESB109	2	
U BOLTS - NO OVERLOAD LEAF	OMEU77	4	
U BOLTS - WITH OVERLOAD LEAF	OMEU78		
EXTRA LEAF	EL40XL	2	
CENTRE BOLT- OVERLOAD ONLY	UCB21		

FORD F250 & F350 2008 TO 2010

FRONT <i>Estimated Lift: 45mm (2 inch)</i>	DIESEL ENGINE		
	PART NUMBER	QTY	UNIT PRICE \$
SPRING: 45MM	2768	1	
NITROCHARGER SPORT	60123	2	
CASTER CORRECTION KIT	FK81 6	1	

FRONT <i>Estimated Lift: 75 - 100mm (3 inch to 4 inch)</i>	DIESEL ENGINE		
	PART NUMBER	QTY	UNIT PRICE \$
SPRING: 75MM	3075 1	1	
NITROCHARGER SPORT	60121 2	2	
SPRING: 100MM	3076 1	1	
NITROCHARGER SPORT	60121 2	2	
PANHARD BRACKET	FK69	1	
RADIUS ARM DROP BRACKET KIT	FK80		
BRAKELINE BRACKET KIT	FK71		
SWAYBAR BRACKET KIT	FK72		
BUMP SPACER KIT	FK73		
TRIM PACKET (10mm)	FK74 3		

REAR <i>Estimated Lift: 75mm (3 inch)</i>	ALL MODELS		
	PART NUMBER	QTY	UNIT PRICE \$
SPRING: MEDIUM LOAD	EL077R 4	2	
SPRING: CONSTANT 450 KGS	EL077R + EL40XL	2 + 2	
NITROCHARGER SPORT	60122	2	
SPRING BUSH KIT	OMESB109	2	
U BOLTS - NO OVERLOAD LEAF	OMEU79	4	
U BOLTS - WITH OVERLOAD LEAF	OMEU80 5		
EXTRA LEAF	EL40XL	2	
CENTRE BOLT - OVERLOAD ONLY	UCB21 4		

REMARKS:

- 1** When fitting either 3075 or 3076 it is **mandatory** to fit Bump Spacer Kit FK73 prevent the coil from being over stressed.
- 2** OME front shock 60121 is not suitable as an OE replacement. When fitting longer OME shock 60121 you must fit:
 - FK71 Brakeline Kit to extend / drop the brakelines
 - FK72 Swaybar Kit to lower the front swaybar
 - FK80 Radius Arm Drop Bracket Kit, if not fitted you may over stretch the front brakelines
- 3** When bull bar and / or winch are fitted use FK74 on both coils to restore nominal lift height.
- 4** Where the OE rear leaf spring has an overload leaf fitted, this overload leaf is to be fitted to the OME leaf, EL077R is to have its centre bolt replaced with a longer bolt UCB21 and OE spacer blocks are to be reused.
- 5** Use OMEU79 when fitting to a vehicle without an overload leaf.
Use OMEU80 when fitting to a vehicle with an overload leaf.
- 6** Fitment of a FK81 Caster Correction Kit will provide approximately 3.5 to 4.0 degrees of extra caster. It is advisable to have a front end alignment carried out to determine if a FK81 kit is required.

FORD F250 & F350 2005 TO 2008 ALL MODELS

FRONT <i>Estimated Lift: 45mm</i>	V8 DIESEL: COIL SPRING		
	PART NUMBER	QTY	UNIT PRICE \$
SPRING: TO 100 KGS	2768	1	
NITROCHARGER	N195	2	
CASTER CORRECTION KIT	FK36 4	1	

REAR <i>Estimated Lift: 50mm</i>	ALL MODELS LEAF SPRING		
	PART NUMBER	QTY	UNIT PRICE \$
SPRING: MEDIUM LOAD	CS048R 1	2	
THIRD STAGE	TSXL01 1		
SPRING: CONSTANT 600+KGS	CS048R 1	2	
XL LEAF	D27XL 2		
CENTRE BOLT	UCB10 1		
NITROCHARGER	N179		
U BOLTS - NO OVERLOAD LEAF	OMEU68	4	
U BOLTS - WITH OVERLOAD LEAF	OMEU67 1		
FITTING KIT	FK31 3	1	
	FK35		
SPACER KIT	OMESK1 3		

REMARKS:

- 1** Springs are supplied with bushes fitted. Where the OE spring has an overload leaf fitted, it must be replaced with a TSXL01 and the CS048R original centre bolt replaced by a UCB10, the original spacing block must also be re-fitted using U Bolts OMEU67.

- 2** To maintain 50mm lift for loads over constant 600kgs add one (1) D27XL Extra Leaf.

- 3** Fitment of Driveline Spacer Kit FK31 for Crew Cab or FK35 for Xtra Cab is recommended to reduce possible driveline vibration. If required, additional spacing down of the centre bearing can be achieved by using an OMESK1 Spacer Kit.

- 4** Fitment of a FK36 Caster Correction Kit will provide approximately 3.5 to 4.0 degrees of extra caster. It is advisable to have a Front End Alignment carried out to determine if an FK36 kit is required.

FORD F250 & F350 1999 TO 2004 ALL MODELS⁷

FRONT <i>Estimated Lift: 50mm</i>	F250 PETROL & DIESEL			F350 PETROL & DIESEL		
	PART NUMBER	QTY	UNIT PRICE \$	PART NUMBER	QTY	UNIT PRICE \$
SPRING: TO 150 KGS	CS018F 1 6	2		CS018F 1 6	2	
NITROCHARGER	N178			N178		
ADJUSTABLE PANHARD ROD	APRF250 1	1		APRF250 1	1	
U BOLTS - USA MODELS	OMEU69	2		OMEU69	4	
	OMEU69A					
	OMEU70					
U BOLTS - BRAZIL MODELS	OMEU70A			-		
				-		

REAR <i>Estimated Lift: 50mm</i>	F250 ALL MODELS			F350 ALL MODELS			
	PART NUMBER	QTY	UNIT PRICE \$	PART NUMBER	QTY	UNIT PRICE \$	
SPRING: TO 600 KGS	CS048R	2		CS048R	2		
THIRD STAGE	-			TSXL01 5			
NITROCHARGER - SINGLE FITMENT	N179	2		N179			
NITROCHARGER - DUAL FITMENT	N179 + N180 2	2 + 2		-			
SPRING: CONSTANT 600 KGS	CS048R 3	2		CS048R 5 3	2		
XL LEAF	D27XL			D27XL			
THIRD STAGE	-			TSXL01 5			
NITROCHARGER - SINGLE FITMENT	N179	2		N179			
NITROCHARGER - DUAL FITMENT	N179 + N180 2	2 + 2		-			
U BOLTS	OMEU68	4		OMEU67	4		
CENTRE BOLT	UCB10	2		UCB10	2		
FITTING KIT	FK31 4	1		FK31 4	1		
	FK35			FK35 4			
STONE GUARD KIT	OME660 2			OME660 2			

REMARKS:

- 1** AFR250 Adjustable Panhard Rod **must** be fitted to allow original axle location to be restored, bushes are supplied in rod.
- 2** For F250 Models with dual shock fitment N179 **must** be fitted rear of the axle, as it is longer than the N180. For both F250 and F350 Models OME660 Stone Shields are also a recommended fitment to the rear shocks.
- 3** To help maintain 50mm lift, add one D27XL Extra Leaf for every 400kgs carried over 600kgs.
- 4** Fitment of FK31 to Crew Cab or FK35 to Xtra Cab Models is recommended to reduce possible driveline vibration.
- 5** As the CS048R has a different spring camber, compared to the original spring, the overload leaf **must** be replaced with a TSXL01. The Original spacing block **must** be refitted. Springs are supplied with bushing.
- 6** Springs are supplied with bushing.
- 7** Incompatible with F350 Dual Axle Model.

JACKAROO/TROOPER & MONTEREY 3/2001 TO 2004 SWB & LWB

FRONT			
	PART NUMBER	QTY	UNIT PRICE \$
TORSION BARS	-	1	
NITROCHARGER SPORT	60031	2	

REAR				
<i>Estimated Lift: 20mm</i>		PART NUMBER	QTY	UNIT PRICE \$
SPRING: MEDIUM LOAD	2919	1		
NITROCHARGER SPORT	60074	2		
SPRING: CONSTANT 100 KGS	2929	1		
NITROCHARGER SPORT	60074	2		

REMARKS:

- 1** Raise or lower front end clearance and trim vehicle by adjusting front torsion bars. **Important:** A minimum of 60mm of droop **must** be maintained.
- 2** Coil **must** be installed with progressive rate to the top.

JACKAROO/TROOPER & MONTEREY 1992 TO 2/2001 SWB & LWB

FRONT			
	PART NUMBER	QTY	UNIT PRICE \$
TORSION BARS	-	1	
NITROCHARGER SPORT	60031	2	

REAR				
<i>Estimated Lift: 25mm</i>		PART NUMBER	QTY	UNIT PRICE \$
SPRING: MEDIUM LOAD	2912	1		
NITROCHARGER SPORT	60074	2		
SPRING: CONSTANT 100 KGS	2919	1		
NITROCHARGER SPORT	60074	2		

REMARKS:

- 1** Raise or lower front end clearance and trim vehicle by adjusting front torsion bars. **Important:** A minimum of 60mm of droop **must** be maintained.
- 2** Coil **must** be installed with progressive rate to the top.

JACKAROO/ISUZU TROOPER 1982 TO 3/1992 ALL MODELS

FRONT			
	PART NUMBER	QTY	UNIT PRICE \$
TORSION BARS: OVER 50 KGS	303004 1	1	
NITROCHARGER SPORT	60031	2	

REAR		ALL MODELS	
<i>Estimated Lift: 20mm</i>			
	PART NUMBER	QTY	UNIT PRICE \$
SPRING: MEDIUM LOAD	CS028R		
NITROCHARGER SPORT	60009 2	2	
	60032 2		
NITROCHARGER	*N42 / N89 2		
SPRING: CONSTANT 200 KGS	CS029R		
NITROCHARGER SPORT	*60063 / 60009 2	2	
	*60064 / 60032 2		
NITROCHARGER	N42 2		
SHOCK BUSH KIT CONVERTER	OMEB11		
SPRING BUSH KITS	OMESB80	2	
U BOLTS	OMEU59A 3	4	
ANTI INVERSION KIT	FK14 4	1	
GREASABLE SHACKLE KIT	OMEGS13		
EXTRA LEAF	D19XL	2	
CENTRE BOLT	UCB16		

REMARKS:

- 1 Raise or lower front end clearance and trim vehicle by adjusting front torsion bars. Torsion Bar 303004 suit Models from 8/88 To 3/92 only.
Important: A minimum of 60mm of droop **must** be maintained.
- 2 60009 / 60063: Suits 11/'86 To 3/'92 Models and requires OMEB11 Bush Kit to convert lower bush from 19mm to 16mm ID.
60064 / 60032 / N42 / N89: Suits Models '82 To 10/'86 (no bush kit required).
- 3 Where the OE spring has 4 leaves OMEU59A U Bolts are required.
- 4 FK14 Anti Inversion Kit **must** be fitted if greasable shackles are not fitted.

GM FRONTERA 5 DOOR 1999 TO 6/2003 (USA - ISUZU RODEO WAGON)

FRONT			
	PART NUMBER	QTY	UNIT PRICE \$
TORSION BARS	-		
NITROCHARGER SPORT	60031	2	

REAR		ALL MODELS	
<i>Estimated Lift: 20mm</i>			
	PART NUMBER	QTY	UNIT PRICE \$
SPRING: MEDIUM LOAD	2913	1	
NITROCHARGER	N102	2	

GM FRONTERA 1995 TO 1998 (USA - ISUZU RODEO WAGON) 2 & 4 DOOR UT MODELS

FRONT	ALL MODELS		
	PART NUMBER	QTY	UNIT PRICE \$
TORSION BARS	-		
NITROCHARGER SPORT	60031	2	

REAR	ALL MODELS		
	PART NUMBER	QTY	UNIT PRICE \$
<i>Estimated Lift: 40mm</i>			
SPRING: MEDIUM LOAD	2912	1	
NITROCHARGER SPORT	60074	2	

TRAILBLAZER 2017 ON COLORADO 7 2013 TO 2016 ALL MODELS MU-X 2013 ON ALL MODELS

FRONT	DIESEL ENGINE		
	PART NUMBER	QTY	UNIT PRICE \$
<i>Estimated Lift: 30mm</i>			
SPRING: No Bar	3057	1	
STRUT - SPORT	90022 1	2	
SPRING: Bar	2883	1	
STRUT - SPORT	*90023 / 90022 1	2	
SPRING: Bar / Winch	2869	1	
STRUT - SPORT	90023 1	2	
TRIM PACKER	OME95PF5		
UPPER STRUT BUSHES	OME3134 1	2	
COIL ISOLATER	OMESB3014 2		
STRUT TOP HAT KIT	OMETH004 3		

REAR	MU-X			COLORADO 7 & TRAILBLAZER		
	PART NUMBER	QTY	UNIT PRICE \$	PART NUMBER	QTY	UNIT PRICE \$
<i>Estimated Lift: 40mm</i>						
SPRING: MEDIUM LOAD	3088	1		3091	1	
NITROCHARGER SPORT	60130	2		60130 4	2	
SPRING: CONSTANT 200 KGS	3089	1		3092	1	
NITROCHARGER SPORT	*60131 / 60130	2		*60131 / 60130 4	2	
SPRING: CONSTANT 400 KGS	3090	1		3093	1	
NITROCHARGER SPORT	60131	2		60131 4	2	

REMARKS:

- 1** No top mounting bushes supplied, use OME3134. OE bushes may be re-used if in good condition. OME struts can only be installed with OME coils.
- 2** Colorado 04/13 To 2016, due to change in top hat OMESB3014 will be required for fitment of OME coils. Please note: Only needed for up to 2015 Models. Not required for Trailblazer 2017 On Models or Isuzu MU-X.
- 3** Strut Top Hat Kit may be required if original equipment is worn.
- 4** 60130 and 60131 **cannot** be used as a shock only OE replacement on Colorado 7/Trailblazer Models. Can be used as an OE replacement for Isuzu MU-X.

DMAX 2012 ON ALL MODELS COLORADO 2012 ON ALL MODELS

FRONT <i>Estimated Lift: 30mm</i>	DIESEL ENGINE		
	PART NUMBER	QTY	UNIT PRICE \$
SPRING: No Bar	3057	1	
STRUT SPORT	90022 1	2	
SPRING: Bar	2883	1	
STRUT SPORT	*90023 / 90022 1	2	
SPRING: Bar / Winch	2869	1	
STRUT SPORT	90023 1	2	
SPRING: Bar, Winch & Accessories	3114	1	
STRUT SPORT	90023 1	2	
TRIM PACKER	OME95PF5		
UPPER STRUT BUSHES	OME3134 1		
COIL ISOLATOR	OMESB3014 6	2	
STRUT TOP HAT KIT	OMETH004 5		

REAR <i>Estimated Lift: 30mm</i>	ALL MODELS		
	PART NUMBER	QTY	UNIT PRICE \$
SPRING: MEDIUM LOAD	EL072R		
NITROCHARGER SPORT	60116	2	
SPRING: CONSTANT 300 KGS	EL073R		
NITROCHARGER SPORT	*60117 / 60116	2	
SPRING: CONSTANT 600 KGS	EL074R 3		
NITROCHARGER SPORT	60117	2	
GREASABLE SHACKLE KIT	OMEGS14	1	
SPRING BUSH KIT	OMESB98		
	OMESB107 2	2	
U BOLTS	OMEU53A		
	OMEU53B 3	4	
EXTRA LEAF	EL39XL 3	2	
HANDBRAKE CABLE FIT KIT	FK66 4		
	FK87	1	

REMARKS:

- 1** No top mounting bushes supplied, use OME3134. OE bushes may be re-used if in good condition. OME struts can only be installed with OME coils.
- 2** OMESB98 Bush Kit suits OME Greasable Shackle, OMEGS14. OMESB107 Bush Kit suits OE Shackle.
- 3** If fitting extra leaf to EL074R, use U Bolt OMEU53B.
- 4** Handbrake Cable Fit Kit FK66 required for Isuzu DMAX cab chassis and LSM Models. FK87 required for Colorado 2016 On Models.
- 5** Strut Top Hat Kit may be required if original equipment is worn.
- 6** Colorado 04/13 onwards, due to change in top hat OMESB3014 will be required for fitment of OME coils. Please note: Only needed for up to 2015 Models. Not required for Colorado 2016 On Models or Isuzu DMAX.

DMAX 2008 TO 2011 ALL MODELS

COLORADO RC 2008 TO 2011 ALL MODELS

RODEO RA 2003 TO 2011 ALL MODELS (NOT USA MANUFACTURED MODEL)

FRONT	PETROL ENGINE			DIESEL ENGINE		
	PART NUMBER	QTY	UNIT PRICE \$	PART NUMBER	QTY	UNIT PRICE \$
TORSION BARS - NO LOAD	303012 ^[1]	1		303012 ^[1]	1	
NITROCHARGER SPORT	60031	2		60031	2	

REAR <i>Estimated Lift: 30 - 50mm</i>	ALL MODELS		
	PART NUMBER	QTY	UNIT PRICE \$
SPRING: MEDIUM LOAD	CS062R ^[2]	2	
NITROCHARGER SPORT	60032		
NITROCHARGER	*N42 / N89		
SPRING: CONSTANT 300 KGS	CS063R ^[2]	2	
NITROCHARGER SPORT	*60064 / 60032		
NITROCHARGER	N42		
SPRING BUSH KIT	OMESB80	2	
U BOLTS	OMEU66	4	
CENTRE BOLT	UCB15	2	
ANTI INVERSION KIT	FK26 ^[3]	1	
GREASABLE SHACKLE KIT	OMEGS13		
EXTRA LEAF	D26XL	2	

REMARKS:

- 1** Raise or lower front end clearance and trim vehicle by adjusting front torsion bars. **Important:** A minimum of 60mm of droop must be maintained. It has been found, due to vehicle manufacturing tolerances, that in some cases front shock absorbers may contact the steering arm when on full lock. Fitter should check for this and where required a small indentation should be made to the body of the shock absorber. 303012 torsion bars have a lighter rate than OE and improve ride comfort for vehicles with no front accessory weight. Due to their heavy rate, the OE torsion bars are suitable for vehicles with front accessory weight.
- 2** Include tray weight in constant load calculation. CS062R and CS063R can be installed to high height 4x2 Models. OME leaf does not fit low height 4x2 Models.
- 3** FK26 only needed if not fitting Greasable Shackle Kit.

RODEO/DMAX TO 2003 ALL MODELS (NOT USA MANUFACTURED MODEL)

FRONT	PETROL & DIESEL ENGINES		
	PART NUMBER	QTY	UNIT PRICE \$
TORSION BARS: OVER 50 KGS	303004 ¹	1	
NITROCHARGER SPORT	60031	2	

REAR <i>Estimated Lift: 20mm</i>	ALL MODELS		
	PART NUMBER	QTY	UNIT PRICE \$
SPRING: MEDIUM LOAD	CS028R ² ³	2	
NITROCHARGER SPORT	60032		
NITROCHARGER	*N42 / N89		
SPRING: CONSTANT 400 KGS	CS029R ² ³	2	
NITROCHARGER SPORT	60064		
NITROCHARGER	N42		
SPRING BUSH KIT	OMESB80	2	
ANTI INVERSION KIT	FK14	1	
GREASABLE SHACKLE KIT	OMECS13 ³		
U BOLTS	OMEU59A ⁴	4	
EXTRA LEAF	D19XL	2	
CENTRE BOLT	UCB16		

REMARKS:

- 1** Raise or lower front end clearance and trim vehicle by adjusting front torsion bars. **Important:** A minimum of 60mm of droop **must** be maintained.
- 2** Include tray weight in constant load calculation.
- 3** FK14 **must** be fitted if OMECS13 greasable shackles are not fitted.
- 4** Vehicles with 4 Leaf OE spring stack require U bolts OMEU59A.

DROVER ALL MODELS (NOT USA MANUFACTURED MODEL)

FRONT <i>Estimated Lift: 40mm</i>			
	PART NUMBER	QTY	UNIT PRICE \$
SPRING: TO 35 KGS	CS012FA / B	1 + 1	
NITROCHARGER	OME015	2	
SPRING: 35 TO 75 KGS	CS013FA / B	1 + 1	
NITROCHARGER	OME015	2	
SPRING BUSH KIT	OMESB19	2	
U BOLTS	OMEU61	4	
	OMEU62 ¹	1	
FITTING KIT	FK06		
TRIM PACKER	TP05		
STEERING DAMPER	OMESD30	1	
EXTRA LEAF	D20XL	2	
CENTRE BOLT	UCB7		

REAR <i>Estimated Lift: 40mm</i>	ALL MODELS		
	PART NUMBER	QTY	UNIT PRICE \$
SPRING: MEDIUM LOAD	CS038R	2	
NITROCHARGER	OME013		
SPRING: CONSTANT 100 KGS	CS039R	2	
NITROCHARGER	OME013		
SPRING BUSH KIT	OMESB19	2	
U BOLTS	OMEU61	4	
TRIM PACKER	TP05		
EXTRA LEAF	D21XL	2	
CENTRE BOLT	UCB7		

REMARKS:

- 1** One only OMEU62 may be required on the right hand side inner, on some Models.

HUMMER

H3

FRONT <i>Estimated Lift: 20mm</i>	ALL MODELS		
	PART NUMBER	QTY	UNIT PRICE \$
TORSION BARS	303014 ¹	1	
NITROCHARGER SPORT	90001	2	

REAR <i>Estimated Lift: 20mm</i>	ALL MODELS		
	PART NUMBER	QTY	UNIT PRICE \$
SPRING: MEDIUM LOAD	CS059R ²	2	
NITROCHARGER SPORT	60045		
EXTRA LEAF	D36XL	2	

REMARKS:

- 1** Raise or lower front end clearance and trim vehicle by adjusting front torsion bars. It is **important** that a minimum of 60mm droop is maintained to prevent topping out of the front shock absorbers.
- 2** Springs supplied with bushings.



HYUNDAI

TERRACAN 2001 ON

FRONT <i>Estimated Lift: 10mm</i>	PETROL & DIESEL ENGINE		
	PART NUMBER	QTY	UNIT PRICE \$
TORSION BARS	-		
NITROCHARGER SPORT	60040	2	

REAR <i>Estimated Lift: 20mm</i>	ALL MODELS		
	PART NUMBER	QTY	UNIT PRICE \$
SPRING: MEDIUM LOAD	2603	1	
NITROCHARGER SPORT	60060	2	
SPRING: CONSTANT 200 KGS	2604	1	
NITROCHARGER SPORT	60060	2	

KIA

SORENTO BL TO 2009

FRONT <i>Estimated Lift: 20mm</i>	ALL MODELS		
	PART NUMBER	QTY	UNIT PRICE \$
SPRING:	2902	1	
SPRING: 20 TO 60 KGS	2601	1	
STRUT	N148S LHS	N147S RHS	1 + 1

REMARKS:

- 1 OME661 Stone Guards are recommended fitment to vehicles driven on dirt roads to prevent stone damage to the shock absorbers.
- 2 N147S fits RHS, N148S fits LHS.
No top mounting bushes supplied, re-use OE bushes.

REAR <i>Estimated Lift: 30mm</i>	LATE 2006 ON MODELS		
	PART NUMBER	QTY	UNIT PRICE \$
SPRING: LIGHT LOAD	-		
NITROCHARGER	-		
SPRING: MEDIUM LOAD	2622	1	
NITROCHARGER	N205	2	

MODELS 2003 TO LATE 2006

PART NUMBER	QTY	UNIT PRICE \$
2602	1	
N149 1	2	
2903	1	
N149 1	2	

LADA

NIVA

FRONT <i>Estimated Lift: 30mm</i>			
	PART NUMBER	QTY	UNIT PRICE \$
SPRING:	2791 1	1	
NITROCHARGER	NOT AVAILABLE		
TRIM PACKER	OMELNF10		

REMARKS:

- 1 2010 On Models front lift less than 30mm.

REAR <i>Estimated Lift: 30mm</i>	ALL MODELS		
	PART NUMBER	QTY	UNIT PRICE \$
SPRING: MEDIUM LOAD	2792	1	
NITROCHARGER	NOT AVAILABLE		

LAND ROVER

DISCOVERY 3 2005 ON ALL COIL MODELS

FRONT <i>Estimated Lift: 50mm</i>	PETROL & DIESEL ENGINES		
	PART NUMBER	QTY	UNIT PRICE \$
SPRING:	2744	1	
SPRING: 100 KGS +	2745		
STRUT	USE OE <input type="checkbox"/> 1		

REAR <i>Estimated Lift: 50mm</i>	ALL MODELS		
	PART NUMBER	QTY	UNIT PRICE \$
SPRING: MEDIUM LOAD	2746	1	
SPRING: CONSTANT 200 KGS	2743		
STRUT	USE OE <input type="checkbox"/> 1		

REMARKS:

- 1** Coils are suitable to be used with original OE struts, OME will not be developing replacement struts.

DISCOVERY 1999 TO 2004 ALL COIL SUSPENSION MODELS

FRONT <i>Estimated Lift: 40mm</i>	PETROL & DIESEL ENGINES		
	PART NUMBER	QTY	UNIT PRICE \$
SPRING: TO 20 KGS	2776 <input type="checkbox"/> 1	1	
NITROCHARGER SPORT	60024	2	
NITROCHARGER	N107 <input type="checkbox"/> 3		
SPRING: 21 TO 50 KGS	2777 <input type="checkbox"/> 1	1	
NITROCHARGER SPORT	60024	2	
NITROCHARGER	N107 <input type="checkbox"/> 3		
SPRING: 51 TO 110 KGS	2779 <input type="checkbox"/> 1	1	
NITROCHARGER SPORT	60024	2	
NITROCHARGER	N107 <input type="checkbox"/> 3		
STEERING DAMPER	OMESD02	1	
COIL PACKER	OMELRCP2 <input type="checkbox"/> 2		

REAR <i>Estimated Lift: 40mm</i>	ALL MODELS		
	PART NUMBER	QTY	UNIT PRICE \$
SPRING: MEDIUM LOAD	2781	1	
NITROCHARGER SPORT	60026	2	
SPRING: CONSTANT 100 KGS	2762	1	
NITROCHARGER SPORT	60025	2	
SPRING: CONSTANT 200 KGS	2763	1	
NITROCHARGER SPORT	60025	2	
COIL PACKER	OMELRCP1 <input type="checkbox"/> 2		

REMARKS:

- 1** On 2003 Models lift will be between 25 to 35mm.
- 2** 8mm Steel Coil Seat Packer, refer to fitting instructions supplied with packer.
Important: To prevent possible over stressing of the spring, only one packer can be fitted under each coil seat.
- 3** When remaining stock of N107 is exhausted no further product will be available.

LAND ROVER

DISCOVERY TO 1998 & RANGE ROVER TO 5/1995³

FRONT <i>Estimated Lift: To 40mm</i>	PETROL ENGINES			DIESEL ENGINES		
	PART NUMBER	QTY	UNIT PRICE \$	PART NUMBER	QTY	UNIT PRICE \$
SPRING: TO 20 KGS: 20mm	2760	1		-		
NITROCHARGER SPORT	60037	2		-		
NITROCHARGER	N45F 4					
SPRING: TO 50 KGS: 30mm	2761	1		2751	1	
NITROCHARGER SPORT	60037	2		60037	2	
NITROCHARGER	N45F 4					
SPRING: 51 TO 110 KGS	2767	1		2767	1	
NITROCHARGER SPORT	60037	2		60037	2	
STEERING DAMPER	OMESD11	1		OMESD11	1	
CASTER KIT	CALR1 1					
	CALR2 1					
COIL PACKER	OMELRCP1 2			OMELRCP1 2		

REAR <i>Estimated Lift: 40mm</i>	ALL MODELS		
	PART NUMBER	QTY	UNIT PRICE \$
SPRING: MEDIUM LOAD	2764	1	
NITROCHARGER SPORT	60038	2	
SPRING: CONSTANT 100 KGS	2762	1	
NITROCHARGER SPORT	60039	2	
SPRING: CONSTANT 200 KGS	2763	1	
NITROCHARGER SPORT	60039	2	
COIL PACKER	OMELRCP1 2		

REMARKS:

- 1 CALR1 : Fits pre '86 Range Rover.
CALR2 : Fits post '86 Range Rover, all Discovery and Defender 130 Dual Cab Utility.
NB: Do not fit to automatic Range Rovers or Discovery due to possible vibration problems.
- 2 8mm Steel Coil Seat Packer, refer to fitting instructions supplied with packer.
Important: To prevent possible over stressing of the spring, only one packer can be fitted under each coil seat.
- 3 Not suitable for Models with air suspension.
- 4 When remaining stock of N45F is exhausted no further product will be available.

LAND ROVER

DEFENDER & COUNTY 110

FRONT <i>Estimated Lift: To 40mm</i>	V8 PETROL ENGINES			3.9 ISUZU DIESEL ENGINES		
	PART NUMBER	QTY	UNIT PRICE \$	PART NUMBER	QTY	UNIT PRICE \$
SPRING: TO 50 KGS: 30mm Lift	2761	1		2766	1	
NITROCHARGER SPORT	60037 ¹	2		60037 ¹	2	
NITROCHARGER	N45F ^{1 5}			N45F ^{1 5}		
SPRING: 51 TO 110 KGS	2751	1		2766	1	
NITROCHARGER SPORT	60037 ¹	2		60037 ¹	2	
STEERING DAMPER	OMESD32			OMESD32		
CASTER KIT	CALR1	1		CALR1	1	
	CALR2 ¹					
COIL PACKER	OMELRCP1 ⁴			OMELRCP1 ⁴		

FRONT <i>Estimated Lift: To 40mm</i>	2.5 DIESEL ENGINES		
	PART NUMBER	QTY	UNIT PRICE \$
SPRING: TO 50 KGS: 30mm Lift	2751	1	
NITROCHARGER SPORT	60037 ¹	2	
NITROCHARGER	N45F ^{1 5}		
SPRING: 51 TO 110 KGS	2767	1	
NITROCHARGER SPORT	60037 ¹	2	
STEERING DAMPER	OMESD32		
CASTER KIT	CALR1	1	
	CALR2 ¹		
COIL PACKER	OMELRCP1 ⁴		

REAR <i>Estimated Lift: To 55mm</i>	ALL MODELS		
	PART NUMBER	QTY	UNIT PRICE \$
SPRING: LIGHT LOAD: 25mm Lift	2752 ²	1	
NITROCHARGER SPORT	60038	2	
SPRING: CONSTANT 300 KGS	2755	1	
NITROCHARGER SPORT	60039	2	
SPRING: CONSTANT 500 KGS	2754 ³	1	
NITROCHARGER SPORT	60039	2	
COIL PACKER	OMELRCP3 ⁴		

REMARKS:

- 1** Caution: Due to altered gearbox mounts on Models after 1998 any lift above OE ride height may cause front driveline vibration that can only be rectified by fitment of front double cardan joints.
Caster Kit will increase caster angle by 2°. Check manufacturer's specifications to determine if Caster Kit is required.
CALR1 suits 38mm wide control arms. CALR2 suits 44mm wide control arms.
- 2** 2752 coil has a softer spring than OE coil. This is to provide improved ride quality with light loads only.
OE springs are designated as medium load springs.
- 3** Original inner helper coil, where fitted, **must** be re-installed with OME Coils.
- 4** 8mm Steel Coil Seat Packer, refer to selection chart supplied with packer.
Important: To prevent possible over stressing of the spring, only one packer can be fitted under each coil seat.
- 5** When remaining stock of N45F is exhausted no further product will be available.

DEFENDER 110 LONG TRAVEL

FRONT <i>Estimated Lift: To 50mm</i>	2.5L DIESEL ENGINES		
	PART NUMBER	QTY	UNIT PRICE \$
SPRING: NO BAR	3062 1	1	
NITROCHARGER SPORT	60018 2	2	
SPRING: BAR / BAR & WINCH	3063 1	1	
NITROCHARGER SPORT	*60070 / 60018 2	2	
STEERING DAMPER	OMESD32	1	
CASTER KIT	CALR1 3		
	CALR2		
COIL PACKER	OMELRCP1 4		

REAR <i>Estimated Lift: To 50mm</i>	ALL MODELS		
	PART NUMBER	QTY	UNIT PRICE \$
SPRING: MEDIUM LOAD	3064 1 2 5	1	
NITROCHARGER SPORT	60018 2	2	
SPRING: CONSTANT 300 KGS	3065 1	1	
NITROCHARGER SPORT	*60070 / 60018 2	2	
SPRING: CONSTANT 500 KGS	3066 2 1	1	
NITROCHARGER SPORT	60070 2	2	
REAR UPPER SHOCK MOUNT	FK64	1	
COIL PACKER	OMELRCP3 4		

FRONT & REAR	FITTING KITS		
	PART NUMBER	QTY	UNIT PRICE \$
BUMP SPACER KIT	FK62	1	
SWAY BAR SPACER KIT	FK63 2		

REMARKS:

Caution: Front driveshaft MUST be replaced / modified with Double Cardan Joints and checked for Uni bind with OME shocks installed at droop. FK62, FK63 & FK64 are mandatory fitment also.

- 1** When fitting coil springs recommended, you **must** use 60018 / 60070 shock absorbers to achieve minimum down travel requirement.
- 2** When fitting 60018 / 60070 the following are **mandatory** requirements:
 - * Fit longer coils 3062 - 3066 for springs to remain trapped with shocks fully extended
 - * Fit FK62 to prevent shock damage
 - * Fit FK63 for front driveshaft clearance and rear extended travel
 - * Fit FK64 which replaces OE upper shock mount when fitting rear shocks
 - * Remove any inner helper coils already fitted
- 3** Caster Kit will increase caster angle by 2°. Check manufacturer's specifications to determine if Caster Kit is required. CALR1 suits 38mm wide control arms. CALR2 suits 44mm wide control arms.
- 4** 8mm Steel Coil Seat Packer, refer to selection chart supplied with packer.
Important: To prevent possible over stressing of the spring, only one packer can be fitted under each coil seat.
- 5** **Important:** 3064 has reduced spring rate from OE to provide improved ride quality for light loads.

DEFENDER 130 MODEL

FRONT <i>Estimated Lift: 20mm</i>	2.5 DIESEL ENGINE		
	PART NUMBER	QTY	UNIT PRICE \$
SPRING: TO 50 KGS	2751	1	
NITROCHARGER SPORT	60037	2	
NITROCHARGER	N45F 5		
SPRING: 51 TO 110 KGS	2767	1	
NITROCHARGER SPORT	60037	2	
STEERING DAMPER	OMESD32	1	
CASTER KIT	CALR1 1		
	CALR2		
COIL PACKER	OMELRCP1 3		

REAR <i>Estimated Lift: To 40mm</i>	DIESEL ENGINE		
	PART NUMBER	QTY	UNIT PRICE \$
SPRING: LIGHT LOAD: 25mm Lift	2755 2	1	
NITROCHARGER SPORT	60039	2	
SPRING: CONSTANT 400 KGS	2754 4	1	
NITROCHARGER SPORT	60039	2	
COIL PACKER	OMELRCP3 3		

REMARKS:

- 1** Caution: Due to altered gearbox mounts on Models after 1998 any lift above OE ride height will cause front driveline vibration that can only be rectified by fitment of front double cardan joints.

Caster Kit will increase caster angle by 2°. Check manufacturer's specifications to determine if Caster Kit is required. CALR1 suits 38mm wide control arms. CALR2 suits 44mm wide control arms.
- 2** **Important:** 2755 has reduced spring rate from OE to provide improved ride quality for light loads. Original inner helper coil, where fitted, **must** be re-installed with OME coils.
- 3** 8mm Steel Coil Seat Packer, refer to selection chart supplied with packer. **Important:** To prevent possible overstressing of the spring, only one packer can be fitted under each coil seat.
- 4** Original inner helper coil, where fitted, must be re-installed with OME coils.
- 5** When remaining stock of N45F is exhausted no further product will be available.

DEFENDER 130 LONG TRAVEL

FRONT <i>Estimated Lift: To 30mm</i>	2.5L DIESEL ENGINES		
	PART NUMBER	QTY	UNIT PRICE \$
SPRING: NO BAR	3062 1	1	
NITROCHARGER SPORT	60018 2	2	
SPRING: BAR / BAR & WINCH	3063 1	1	
NITROCHARGER SPORT	*60070 / 60018 2	2	
STEERING DAMPER	OMESD32	1	
CASTER KIT	CALR1 3		
	CALR2		
COIL PACKER	OMELRCP1 4		

REAR <i>Estimated Lift: To 40mm</i>	ALL MODELS		
	PART NUMBER	QTY	UNIT PRICE \$
SPRING: LIGHT LOAD 25mm Lift	3065 1 2 5	1	
NITROCHARGER SPORT	*60070 / 60018 2	2	
SPRING: CONSTANT 400 KGS	3066 1 2	1	
NITROCHARGER SPORT	60070 2	2	
REAR UPPER SHOCK MOUNT	FK64	1	
COIL PACKER	OMELRCP3 4		

FRONT & REAR	FITTING KITS		
	PART NUMBER	QTY	UNIT PRICE \$
BUMP SPACER KIT	FK62	1	
SWAY BAR SPACER KIT	FK63 2		

REMARKS:

Caution: Front driveshaft MUST be replaced / modified with Double Cardan Joints and checked for Uni bind with OME shocks installed at droop. FK62, FK63 & FK64 are mandatory fitment also.

- 1** When fitting coil springs recommended, it is mandatory use 60018 / 60070 shock absorbers to achieve minimum down travel requirement.
- 2** When fitting 60018 / 60070 the following are mandatory requirements:
 - * Fit longer coils 3062 - 3066 for springs to remain trapped with shocks fully extended
 - * Fit FK62 to prevent shock damage
 - * Fit FK63 for front driveshaft clearance and rear extended travel
 - * Fit FK64 which replaces OE upper shock mount when fitting rear shocks
 - * Remove any inner helper coils already
- 3** Caster Kit will increase caster angle by 2°. Check manufacturer's specifications to determine if Caster Kit is required. CALR1 suits 38mm wide control arms. CALR2 suits 44mm wide control arms.
- 4** 8mm Steel Coil Seat Packer, refer to selection chart supplied with packer.
Important: To prevent possible over stressing of the spring, only one packer can be fitted under each coil seat.
- 5** **Important:** 3065 has reduced spring rate from OE to provide improved ride quality for light loads.

LAND ROVER

90 SERIES

FRONT <i>Estimated Lift: 30mm</i>	PETROL ENGINE			DIESEL ENGINE		
	PART NUMBER	QTY	UNIT PRICE \$	PART NUMBER	QTY	UNIT PRICE \$
SPRING: TO 50 KGS	2761	1		2751	1	
NITROCHARGER SPORT	60037	2		60037	2	
NITROCHARGER	N45F 2			-		
SPRING: 51 TO 110 KGS	2751	1		2767	1	
NITROCHARGER SPORT	60037	2		60037	2	
STEERING DAMPER	OMESD32	1		OMESD32	1	
CASTER KIT	CALR1 1			CALR1 1		
	CALR2			CALR2 1		

REAR <i>Estimated Lift: 45 - 55mm</i>	ALL MODELS		
	PART NUMBER	QTY	UNIT PRICE \$
SPRING: MEDIUM LOAD	2764	1	
NITROCHARGER SPORT	60038	2	
SPRING: CONSTANT 200 KGS	2762	1	
NITROCHARGER SPORT	60039	2	

REMARKS:

- 1** Caution: Due to altered gearbox mounts on Models after 1998 any lift above OE ride height may cause front driveline vibration that can only be rectified by fitment of front double cardan joints.
Caster Kit will increase caster angle by 2°. Check manufacturer's specifications to determine if Caster Kit is required. CALR1 suits 38mm wide control arms. CALR2 suits 44mm wide control arms.
- 2** When remaining stock of N45F is exhausted no further product will be available.

BT-50 2011 ON⁹

FRONT <i>Estimated Lift: 50mm</i>	DIESEL ENGINE		
	PART NUMBER	QTY	UNIT PRICE \$
SPRING: No Bar	2997	1	
STRUT SPORT	90019 1	2	
SPRING: Bar	2998	1	
STRUT SPORT	*90020 / 90019 1	2	
SPRING: Bar / Winch	2999	1	
STRUT SPORT	90020 1	2	
SPRING: No Bar: 30mm LIFT	3048	1	
STRUT SPORT	90019 1	2	
BP-51 SELCTION: Estimated Lift 30 - 40mm			
BP-51 COIL OVER FRONT RH	BP5190005R	1	
BP-51 COIL OVER FRONT LH	BP5190005L		
BP-51 FIT KIT FRONT	VM80010011		
TRIM PACKER	FK56 2		
UPPER STRUT BUSHES	OME3135 1	2	
STRUT TOP HAT KIT	OMETH006 7		
REAR <i>Estimated Lift: 50mm</i>	ALL MODELS		
	PART NUMBER	QTY	UNIT PRICE \$
SPRING: MEDIUM LOAD	EL049R 4	2	
NITROCHARGER SPORT	*60101 / 60023		
SPRING: CONSTANT 300 KGS	EL068R 4	2	
NITROCHARGER SPORT	*60102 / 60101		
SPRING: CONSTANT 600 KGS	EL069R 4	2	
NITROCHARGER SPORT	60102		
BP-51 SELECTION			
BP-51 SHOCK REAR RH	BP5160027R	1	
BP-51 SHOCK REAR LH	BP5160027L		
BP-51 FIT KIT REAR	VM80010012		
GREASABLE SHACKLE KIT	OMEGS20	1	
SPRING BUSH KIT	OMESB102 3	2	
	OMESB103		
U BOLTS	OMEU66 4	4	
	OMEU66A 4		
	OMEU66B 4		
DRIVELINE SPACER KIT	FK57 5 8	1	
EXTRA LEAF	EL34XL 6	2	

8 If a TAD102 Frontier tank is installed in the vehicle, when fitting the FK57 spacer kit, the tank will need to be lowered to allow removal of the centre bearing bolts.

9 **Important:** Please refer to TSB003.

REMARKS:

- 1** No top mounting bushes supplied, use OME3135. OE bushes may be re-used if in good condition.
- 2** Trim Packer FK56 provides 10mm lift at the wheel.
- 3** OMESB102 suits OE Shackle.
OMESB103 Bush Kit suits OME Greasable Shackle OMEGS20.
- 4** Use OMEU66 when fitting EL049R.
Use OMEU66A when fitting EL068R and EL069R.
Use OMEU66B when fitting EL069R with EL34XL.
- 5** Fitment of Driveline Spacer Kit FK57 is recommended to re-align driveline.
- 6** EL34XL will give approximately 30mm extra lift or increase loading capacity at design height by approximately 300kg.
- 7** Strut Top Hat Kit may be required if original equipment is worn.

BT-50 1 TONNE 12/2006 TO 2011 ALL MODELS

FRONT	PETROL & DIESEL ENGINES		
	PART NUMBER	QTY	UNIT PRICE \$
TORSION BARS: OVER 60 KGS	303013 1	1	
NITROCHARGER SPORT	60022 2	2	
NITROCHARGER	N194 4		
FITTING KIT	FK22 2	1	

REAR <i>Estimated Lift: 20mm</i>	ALL MODELS		
	PART NUMBER	QTY	UNIT PRICE \$
SPRING: MEDIUM LOAD	CS056R 3 5	2	
NITROCHARGER SPORT	60023		
SPRING: CONSTANT 200 KGS	EL049R 3 5	2	
NITROCHARGER SPORT	60023		
SPRING: CONSTANT 400 KGS	CS060R 3 5	2	
NITROCHARGER SPORT	*60102 / 60023		
GREASABLE SHACKLE KIT	OMEGS18	1	
U BOLTS	OMEU66 3	4	
	OMEU66A		
SPRING BUSH KIT	OMESB97		
EXTRA LEAF	D34XL / EL34XL 5	2	
CENTRE BOLT	UCB19		

REMARKS:

- 1** Some Latin American 12/2006 On Models use 303005 torsion bars, measuring 925mm in length. The 303013 torsion bars measure 1024mm. Check OE torsion bar length before ordering.
- 2** FK22 Front Shock Absorber Upper Mount Supporting Bracket Kit is a **mandatory** fitment.
- 3** Use OMEU66 when fitting CS056R and EL049R. Use OMEU66A when fitting CS060R. Include tray weight in constant load calculation.
- 4** When remaining stock of N187 and N194 is exhausted no further product will be available.
- 5** D34XL and UCB19 suits CS056R and CS060R. EL034XL suits EL049R.

B SERIES 1 TONNE 1987 TO 2006 ALL MODELS

FRONT	PETROL & DIESEL ENGINES		
	PART NUMBER	QTY	UNIT PRICE \$
TORSION BARS: OVER 60 KGS	303005	1	
NITROCHARGER SPORT	60022 1	2	
NITROCHARGER	N51 3		
FITTING KIT	FK22 1	1	

REAR <i>Estimated Lift: 20mm</i>	ALL MODELS		
	PART NUMBER	QTY	UNIT PRICE \$
SPRING: MEDIUM LOAD	CS026R 2	2	
NITROCHARGER SPORT	60023		
SPRING: CONSTANT 200 KGS	CS027R 2	2	
NITROCHARGER SPORT	60023		
U BOLTS	OMEU65	4	
GREASABLE SHACKLE KIT	OMEGS18	1	
SPRING BUSH KIT	OMESB82		
EXTRA LEAF	D9XL	2	
CENTRE BOLT	UCB17		

REMARKS:

- 1** FK22 Front Shock Absorber Upper Mount Supporting Bracket Kit is a **mandatory** fitment.
- 2** Include tray weight in constant load calculation.
- 3** When remaining stock of N51 is exhausted no further product will be available.

G-WAGON G350 BLUETECH / G55 AMG MODELS

FRONT <i>Estimated Lift: 50mm</i>	ALL MODELS		
	PART NUMBER	QTY	UNIT PRICE \$
SPRING: No Bar	3028	1	
STRUT SPORT	60113	2	
SPRING: Bar Or Winch	3029	1	
STRUT SPORT	60113	2	

REAR <i>Estimated Lift: 50mm</i>	ALL MODELS		
	PART NUMBER	QTY	UNIT PRICE \$
SPRING: MEDIUM LOAD	3030	1	
NITROCHARGER SPORT	60114	2	

PAJERO 2007 ON ALL LWB MODELS (11/2006)

FRONT <i>Estimated Lift: 30 - 40mm</i>	V6 PETROL ENGINE			2.8 & 3.2 DIESEL ENGINES		
	PART NUMBER	QTY	UNIT PRICE \$	PART NUMBER	QTY	UNIT PRICE \$
SPRING: NO BAR	3108	1		2914	1	
STRUT - SPORT	90006 2	2		90006 2	2	
SPRING: BAR ONLY	2914	1		3109	1	
STRUT - SPORT	*90007 / 90006 2	2		*90007 / 90006 2	2	
SPRING: BAR & WINCH	3109	1		2915	1	
STRUT - SPORT	90007 2	2		90007 2	2	
UPPER STRUT BUSHES	OME3101 2	2		OME3101 2	2	
STRUT TOP HAT KIT	OMETH007 3			OMETH007 3		

REAR <i>Estimated Lift: 40 - 50mm</i>	ALL MODELS			REMARKS:
	PART NUMBER	QTY	UNIT PRICE \$	
SPRING: MEDIUM LOAD	3110 1	1		1 It is recommended that a 4 wheel alignment is carried out. 2 No top mounting bushes supplied, use OME3101. OE bushes may be re-used if in good condition. 3 Strut Top Hat Kit may be required if original equipment is worn.
NITROCHARGER SPORT	60019	2		
SPRING: CONSTANT 200 KGS	3111 1	1		
NITROCHARGER SPORT	60033	2		
SPRING: CONSTANT 400 KGS	3112	1		
NITROCHARGER SPORT	60033	2		

PAJERO / MONTERO 2000 TO 2006 ALL LWB MODELS (To 10/06)

FRONT <i>Estimated Lift: 35mm</i>	V6 PETROL ENGINE			2.8 & 3.2 DIESEL ENGINES		
	PART NUMBER	QTY	UNIT PRICE \$	PART NUMBER	QTY	UNIT PRICE \$
SPRING: TO 50 KGS	2914	1		2915	1	
STRUT - SPORT	90006 2	2		90006 2	2	
SPRING: 51 TO 100 KGS	2915	1		2924	1	
STRUT - SPORT	90007 2	2		90007 2	2	
UPPER STRUT BUSHES	OME3101 2			OME3101 2		
STRUT TOP HAT KIT	OMETH007 3			OMETH007 3		

REAR <i>Estimated Lift: 40mm</i>	ALL MODELS			REMARKS:
	PART NUMBER	QTY	UNIT PRICE \$	
SPRING: MEDIUM LOAD	2917 1	1		1 It is recommended that a 4 wheel alignment is carried out. 2 No top mounting bushes supplied, use OME3101. OE bushes may be re-used if in good condition. 3 Strut Top Hat Kit may be required if original equipment is worn.
NITROCHARGER SPORT	60019	2		
SPRING: CONSTANT 200 KGS	2918 1	1		
NITROCHARGER SPORT	60033	2		
SPRING: CONSTANT 300 KGS	2995	1		
NITROCHARGER SPORT	60033	2		

PAJERO / MONTERO 2000 ON ALL SWB MODELS

FRONT <i>Estimated Lift: 35mm</i>	V6 PETROL ENGINE			3.2 DIESEL ENGINE		
	PART NUMBER	QTY	UNIT PRICE \$	PART NUMBER	QTY	UNIT PRICE \$
SPRING: TO 50 KGS	2914	1		2915	1	
STRUT - SPORT	90006 2	2		90006 2	2	
SPRING: 51 TO 100 KGS	2915	1		2924	1	
STRUT - SPORT	90007 2	2		90007 2	2	
UPPER STRUT BUSHES	OME3101			OME3101		
STRUT TOP HAT KIT	OMETH007 3			OMETH007 3		

REAR <i>Estimated Lift: 40mm</i>	ALL MODELS		
	PART NUMBER	QTY	UNIT PRICE \$
SPRING: MEDIUM LOAD	2994 1	1	
NITROCHARGER SPORT	60019	2	
SPRING: CONSTANT 200 KGS	2917 1	1	
NITROCHARGER SPORT	60033	2	

REMARKS:

- 1** It is recommended that a 4 wheel alignment is carried out.
- 2** No top mounting bushes supplied, use OME3101. OE bushes may be re-used if in good condition.
- 3** Strut Top Hat Kit may be required if original equipment is worn.

PAJERO / MONTERO 1991 TO 1999 SWB & LWB REAR LEAF SPRING MODELS

FRONT	PART NUMBER	QTY	UNIT PRICE \$
	TORSION BARS: OVER 50 KGS	303010 1	1
	303011		
NITROCHARGER SPORT	60040	2	
NITROCHARGER	N18 3		

REMARKS:

- 1** Raise or lower front end clearance and trim vehicle by adjusting front torsion bars.

Important: A minimum of 60mm of droop must be maintained.

303010 suits 88 To 90 V6 Models and all Models 91 To 94 - length 1278mm.

303011 suits all Models 95 To 00 - length 1308mm.

- 2** OMESB38 must be used to fit OME springs.
- 3** When remaining stock of N18 is exhausted no further product will be available.

REAR <i>Estimated Lift: 45 - 50mm</i>	ALL MODELS		
	PART NUMBER	QTY	UNIT PRICE \$
SPRING: MEDIUM LOAD	CS022R 2	2	
NITROCHARGER SPORT	60057		
SPRING: CONSTANT 250 KGS	CS023R 2	2	
NITROCHARGER SPORT	*60036 / 60057		
SPRING BUSH KIT	OMESB38 2	2	
GREASABLE SHACKLE KIT	OMEGS16	1	

PAJERO / MONTERO 1991 TO 1999 ALL LWB REAR COIL SPRING MODELS

FRONT			
	PART NUMBER	QTY	UNIT PRICE \$
TORSION BARS: OVER 50 KGS	303010 1	1	
	303011		
NITROCHARGER SPORT	60040	2	
NITROCHARGER	N18 2		

REMARKS:

1 Raise or lower front end clearance and trim vehicle by adjusting front torsion bars.

Important: A minimum of 60mm of droop must be maintained.

303010 suits all Models 91 To 94 with 1278mm length.

303011 suits all Models 95 To 00 with 1308mm length.

2 When remaining stock of N18 is exhausted no further product will be available.

REAR	ALL MODELS		
<i>Estimated Lift: To 20mm</i>	PART NUMBER	QTY	UNIT PRICE \$
SPRING: MEDIUM LOAD	2910	1	
NITROCHARGER SPORT	60041	2	
SPRING: CONSTANT 200 KGS	2938	1	
NITROCHARGER SPORT	60041	2	

PAJERO / MONTERO 1991 TO 1999 ALL SWB REAR COIL SPRING MODELS

FRONT			
	PART NUMBER	QTY	UNIT PRICE \$
TORSION BARS	- 1		
NITROCHARGER SPORT	60040	2	
NITROCHARGER	N18 2		

REMARKS:

1 Raise or lower front end clearance and trim vehicle by adjusting front torsion bars.

Important: A minimum of 60mm of droop must be maintained.

2 When remaining stock of N18 is exhausted no further product will be available.

REAR	ALL MODELS		
<i>Estimated Lift: 20mm</i>	PART NUMBER	QTY	UNIT PRICE \$
SPRING: MEDIUM LOAD	2911	1	
NITROCHARGER SPORT	60041	2	

PAJERO / MONTERO TO 1991 REAR LEAF SPRING MODELS (Hyundai Galloper)

FRONT	4 CYLINDER ENGINE		
	PART NUMBER	QTY	UNIT PRICE \$
TORSION BARS: OVER 50 KGS	303009 1	1	
NITROCHARGER SPORT	60051	2	

REMARKS:

1 Raise or lower front end clearance and trim vehicle by adjusting front torsion bars.

Important: A minimum of 60mm of droop must be maintained.

303009 suits 82 To 90 4 cylinder Models - length 1278mm.

2 OMESB8 must be used with CS022R and CS023R springs.

3 OMEU54 only required on SWB Models.

REAR	ALL MODELS		
<i>Estimated Lift: 45 - 50mm</i>	PART NUMBER	QTY	UNIT PRICE \$
SPRING: MEDIUM LOAD	CS022R 2	2	
NITROCHARGER SPORT	60057		
SPRING: CONSTANT 250 KGS	CS023R 2	2	
NITROCHARGER SPORT	*60036 / 60057		
SPRING BUSH KIT	OMESB8 2	2	
U BOLTS	OMEU54 3	4	
GREASABLE SHACKLE KIT	OMEGS16	1	

PAJERO CHALLENGER 1989 TO 1991

REAR COIL SPRING MODELS (Hyundai Galloper) (USA - MONTERO SPORT)

FRONT			
	PART NUMBER	QTY	UNIT PRICE \$
TORSION BARS: OVER 50 KGS	303010 1	1	
NITROCHARGER SPORT	60051	2	

REAR	ALL MODELS		
	PART NUMBER	QTY	UNIT PRICE \$
<i>Estimated Lift: 15mm</i>			
SPRING: MEDIUM LOAD	2910	1	
NITROCHARGER SPORT	60056	2	

REMARKS:

1 Raise or lower front end clearance and trim vehicle by adjusting front torsion bars.

Important: A minimum of 60mm of droop **must** be maintained.

303010 suits 88 To 90 V6 Models.

TRITON / L200 MQ ALL 4X4 MODELS

FRONT			
	PART NUMBER	QTY	UNIT PRICE \$
<i>Estimated Lift: 25mm</i>			
SPRING: NO BAR	3102	1	
STRUT - SPORT	90031 1	2	
SPRING: BAR	3103	1	
STRUT - SPORT	90033 1	2	
SPRING: BAR / WINCH	3104	1	
STRUT - SPORT	90033 1	2	
SPRING: BAR / WINCH / ACCESSORIES	3105	1	
STRUT - SPORT	90033 1	2	
UPPER STRUT BUSHES	OME3121 1	2	
STRUT TOP HAT KIT	OMETH001 2		

REAR	ALL MODELS		
	PART NUMBER	QTY	UNIT PRICE \$
<i>Estimated Lift: 20mm</i>			
SPRING: MEDIUM LOAD	EL086R	2	
NITROCHARGER SPORT	60138		
SPRING: CONSTANT 300 KGS	EL087R	2	
NITROCHARGER SPORT	*60139 / 60138		
SPRING: CONSTANT 600 KGS	EL088R	2	
NITROCHARGER SPORT	*60140 / 60139 3		
GREASABLE SHACKLE KIT	OMEGS23	1	
SPRING BUSH KIT	OMESB113 4	2	
U BOLTS	OMEU53 5	4	
	OMEU53A		
EXTRA LEAF	EL44XL 6	2	

REMARKS:

1 No top mounting bushes supplied use OME3121. OE bushes may be re-used if in good condition. No dirt shield supplied, please re-use OE.

2 Strut Top Hat Kit OMETH001 may be required if original equipment is worn.

3 Shock absorber 60140 is suited for constant rear loading in excess of 800kgs.

4 OMESB113 suits OE Shackle and OME Greasable Shackle, OMEGS23.

5 Use OMEU53A when fitting EL087R and EL088R.

Use OMEU53 when fitting EL086R.

6 EL44XL will give approximately 10mm extra lift or increase loading capacity at design height by approximately 200kgs.

TRITON / L200 ML & MN 2006 TO 2015 ALL MODELS

FRONT <i>Estimated Lift: 10mm</i>	DIESEL ENGINE			V6 PETROL ENGINE		
	PART NUMBER	QTY	UNIT PRICE \$	PART NUMBER	QTY	UNIT PRICE \$
SPRING: NO BAR	2605	1		2611	1	
STRUT - SPORT	90008	2		90008	2	
STRUT	N186S					
SPRING: BAR ONLY	2606	1		2605	1	
STRUT - SPORT	90008	2		90008	2	
STRUT	N186S					
SPRING: BAR & WINCH	3027	1		2606	1	
STRUT - SPORT	90008	2		90008	2	
STRUT	N186S					
UPPER STRUT BUSHES	OME3121	2		OME3121	2	
STRUT TOP HAT KIT	OMETH001					

REAR <i>Estimated Lift: 20mm</i>	ALL MODELS		
	PART NUMBER	QTY	UNIT PRICE \$
SPRING: MEDIUM LOAD	CS053R [1][2][5]	2	
NITROCHARGER SPORT	60036		
NITROCHARGER	N59		
SPRING: CONSTANT 300 KGS	CS054R [1][2][5]	2	
NITROCHARGER SPORT	60036		
NITROCHARGER	N59		
SPRING: CONSTANT 500 KGS	CS022R [1][2][3][6]	2	
NITROCHARGER SPORT	60036		
NITROCHARGER	N59		
SPRING: CONSTANT 800 KGS	CS023R [1][2][3][6]	2	
NITROCHARGER SPORT	60036		
NITROCHARGER	N59		
U BOLTS	OMEU71 [5]	4	
	OMEU76 [6]		
SPRING BUSH KIT	OMESB38 [2]	2	
GREASABLE SHACKLE KIT	OMEGS16 [1]	1	
EXTRA LEAF	D32XL [7]	2	
CENTRE BOLT	UCB5		

REMARKS:

- 1** OMEGS16 is a **mandatory** fitment to prevent springs from inverting.
- 2** OMESB38 is a **mandatory** fitment to OME springs only. Include tray weight in constant load calculation. Springs can **only** be installed with OME Bush Kit.
- 3** Reverse centre bolt to allow fitment.
- 4** No top mounting bushes supplied, use OME3121. OE bushes may be re-used if in good condition.
- 5** OMEU71 is to be used with CS053R and CS054R.
- 6** OMEU76 is to be used with CS022R and CS023R.
- 7** D32XL suitable for CS054R and CS022R.
- 8** Strut Top Hat Kit may be required if original equipment is worn.

TRITON / L200 MK 10/1996 TO 2006 ALL MODELS

FRONT	PETROL & DIESEL ENGINES		
	PART NUMBER	QTY	UNIT PRICE \$
TORSION BARS: OVER 50 KGS	303006 1	1	
NITROCHARGER SPORT	60040	2	
NITROCHARGER	N18 4		

REAR <i>Estimated Lift: To 40mm</i>	ALL MODELS		
	PART NUMBER	QTY	UNIT PRICE \$
SPRING: MEDIUM LOAD	CS022R 2 3	2	
NITROCHARGER SPORT	60050		
NITROCHARGER	N30E		
SPRING: CONSTANT 200 KGS	CS023R 2 3	2	
NITROCHARGER SPORT	60050		
NITROCHARGER	N30E		
U BOLTS	OMEU57	4	
SPRING BUSH KIT	OMESB38 2	2	
ANTI-INVERSION KIT	FK30	1	
GREASABLE SHACKLE KIT	OMEKS16 3		

REMARKS:

- 1** Raise or lower front end clearance and trim vehicle by adjusting front torsion bars. **Important:** A minimum of 60mm of droop **must** be maintained. Torsion bar 303006 suits 1993 On Models with 39 splines.
- 2** OMESB38 is a **mandatory** fitment to OME springs only. Include tray weight in constant load calculation. Springs can **only** be installed with OME bush kits.
- 3** FK30 Anti-Inversion Kit is a **mandatory** fitment, with or without Greasable Shackle Kit.
- 4** When remaining stock of N18 is exhausted no further product will be available.

TRITON / L200 TO 1996 ALL MODELS

FRONT	PETROL & DIESEL ENGINES		
	PART NUMBER	QTY	UNIT PRICE \$
TORSION BARS: OVER 50 KGS	303006 1	1	
NITROCHARGER SPORT	60051	2	

REAR <i>Estimated Lift: To 40mm</i>	ALL MODELS		
	PART NUMBER	QTY	UNIT PRICE \$
SPRING: MEDIUM LOAD	CS022R 2 3	2	
NITROCHARGER SPORT	60058		
NITROCHARGER	N30E		
SPRING: CONSTANT 200 KGS	CS023R 2 3	2	
NITROCHARGER SPORT	60058		
NITROCHARGER	N30E		
U BOLTS	OMEU57	4	
SPRING BUSH KIT	OMESB38 2	2	
ANTI-INVERSION KIT	FK30	1	
GREASABLE SHACKLE KIT	OMEKS16 3		

REMARKS:

- 1** Raise or lower front end clearance and trim vehicle by adjusting front torsion bars. **Important:** A minimum of 60mm of droop **must** be maintained. Torsion bar 303006 suits 1993 On Models with 39 splines.
- 2** OMESB38 is a **mandatory** fitment to OME springs only. Include tray weight in constant load calculation. Springs can **only** be installed with OME bush kits.
- 3** FK30 Anti-Inversion Kit is a mandatory fitment, with or without Greasable Shackle Kit.

CHALLENGER / MONTERO SPORT KH 2010 ON MODELS

FRONT <i>Estimated Lift: 20mm</i>	V6 PETROL ENGINE			DIESEL ENGINE		
	PART NUMBER	QTY	UNIT PRICE \$	PART NUMBER	QTY	UNIT PRICE \$
SPRING: NO BAR	2611	1		2605	1	
STRUT - SPORT	90008	1		90008	1	
STRUT	N186S			2		
SPRING: BAR ONLY	2605	1		2606	1	
STRUT - SPORT	90008	1		90008	1	
STRUT	N186S			2		
SPRING: BAR & WINCH	2606	1		3132	1	
STRUT - SPORT	90008	1		90008	1	
STRUT	N186S			2		
UPPER STRUT BUSHES	OME3121	1		OME3121	1	
STRUT TOP HAT KIT	OMETH001	2		OMETH001	2	

REAR <i>Estimated Lift: 35mm</i>	ALL MODELS		
	PART NUMBER	QTY	UNIT PRICE \$
SPRING: MEDIUM LOAD	2910	1	
NITROCHARGER SPORT	60076	2	
NITROCHARGER	N116		
SPRING: CONSTANT 200 KGS	2938	1	
NITROCHARGER SPORT	*60075 / 60076	2	
NITROCHARGER	N116		
SPRING: CONSTANT 400 KGS	2838	1	
NITROCHARGER SPORT	60075	2	
NITROCHARGER	N116		

REMARKS:

- 1** No top mounting bushes supplied, use OME3121. OE bushes may be re-used if in good condition.
- 2** Strut Top Hat Kit may be required if original equipment is worn.

CHALLENGER / MONTERO SPORT 2000 TO 2008 LWB (COIL REAR MODELS)

FRONT	V6 PETROL ENGINE		
	PART NUMBER	QTY	UNIT PRICE \$
TORSION BARS: OVER 50 KGS	303011	1	
NITROCHARGER SPORT	60040	2	

REAR <i>Estimated Lift: 40mm</i>	ALL MODELS		
	PART NUMBER	QTY	UNIT PRICE \$
SPRING: MEDIUM LOAD	2911	1	
NITROCHARGER SPORT	60059	2	
NITROCHARGER	N116		
SPRING: CONSTANT 200 KGS	2910	1	
NITROCHARGER SPORT	60059	2	
NITROCHARGER	N116		

REMARKS:

- 1** Raise or lower front end clearance and trim vehicle by adjusting front torsion bars. **Important:** A minimum of 60mm of droop **must** be maintained.

CHALLENGER V6 / MONTERO SPORT WAGON PA 1998 TO 2000 (REAR LEAF SPRING MODELS)

FRONT	V6 PETROL ENGINE		
	PART NUMBER	QTY	UNIT PRICE \$
TORSION BARS: OVER 50 KGS	303011 1	1	
NITROCHARGER SPORT	60040	2	

REAR <i>Estimated Lift: 25mm</i>	ALL MODELS		
	PART NUMBER	QTY	UNIT PRICE \$
SPRING: MEDIUM LOAD	CS040R 2 3	2	
NITROCHARGER SPORT	60057		
SPRING: CONSTANT 200 KGS	CS041R 2 3	2	
NITROCHARGER SPORT	*60036 / 60057		
SPRING BUSH KIT	OMESB83 3	2	
GREASABLE SHACKLE KIT	OMEGB16 2	1	
EXTRA LEAF	D7XL	2	
CENTRE BOLT	UCB5		

REMARKS:

- 1 Raise or lower front end clearance and trim vehicle by adjusting front torsion bars.
Important: A minimum of 60mm of droop **must** be maintained.
 303011 suits all Models with bar - length 1308mm.
- 2 OMEGB16 is a **mandatory** fitment to prevent springs from inverting.
- 3 OMESB83 is a **mandatory** fitment to OME springs only. Include tray weight in constant load calculation. Springs can **only** be installed with OME Bush Kit. The Centre Bolt on CS040R **must** be reversed prior to fitment.

PATROL Y62 2010 ON (NON HBMC MODELS)

FRONT <i>Estimated Lift: 40mm</i>	V8 PETROL ENGINE		
	PART NUMBER	QTY	UNIT PRICE \$
SPRING: No Bar	2977	1	
STRUT - SPORT	90014 2	2	
SPRING: Bar	2978	1	
STRUT - SPORT	*90015 / 90014 2	2	
SPRING: Bar / Winch	2979	1	
STRUT - SPORT	90015 2	2	
BP-51 SELECTION			
COIL OVER PATROL Y62 FRONT LH	BP5190008L	1	
COIL OVER PATROL Y62 FRONT RH	BP5190008R		
BP KIT PATROL Y62 FRONT	VM80010020		

ARMOURD APPLICATION - 4.5T
GVM is available refer page 20 for details

REAR <i>Estimated Lift: 50mm</i>	ALL MODELS		
	PART NUMBER	QTY	UNIT PRICE \$
SPRING: MEDIUM LOAD	2986 1	1	
NITROCHARGER SPORT	60084	2	
SPRING: CONSTANT 200 KGS	2987 1	1	
NITROCHARGER SPORT	60084	2	
SPRING: CONSTANT 400 KGS	2988 1	1	
NITROCHARGER SPORT	60084	2	
BP-51 SELECTION			
SHOCK PATROL Y62 REAR	BP5160019	2	
BP KIT PATROL Y62 REAR	VM80010021	1	

REMARKS:

- 1 It is recommended that a 4 wheel, wheel alignment is carried out.
- 2 No top mounting bushes supplied, re-use OE bushes.

OFF ROAD USE ONLY - NISSAN

PATROL Y60 & Y61 LWB

FRONT	PART NUMBER	QTY	UNIT PRICE \$	COMMENTS
COILS				
75mm LIFT - SPRING TO 50KG	2412	1		250 lbf/in
75mm LIFT - SPRING 51 TO 110KG	3033			320 lbf/in
100mm LIFT - SPRING TO 50KG	2413			250 lbf/in
100mm LIFT - SPRING 51 TO 110KG	3036			320 lbf/in
125mm LIFT - SPRING TO 50KG	2414			250 lbf/in
SHOCKS				
NITROCHARGER SPORT	60013L	2		Suits 75mm & 100mm coils
BP-51 SELECTION				
SHOCK: PATROL GU FRONT LONG	BP5160007	2		Suits 75mm & 100mm coils
BP KIT: GU FRONT	VM80010022	1		
STEERING DAMPER				
STABILISER	OMESD34	1		GQ pre 8/89 models
	OMESD36			GQ 8/89 on models
	OMESD11			GU pre 01/00 models
	OMESD01			GU 01/00 on models
COMPONENTS				
ADJUSTABLE PANHARD ROD	PANR004	1		Pre 01/00 wagon CC models, RHD only
	PAN3097A			Pre 01/00 models, LHD only
ADJUSTABLE PANHARD ROD WITH SPH BEARING	PANR028X			01/00 on models not CC, RHD only
SPHERICAL BEARING TO SUIT PANHARD	OME3098			Suits OE and Adjustable 01/00 on
COIL SPRING TRIM PACKER	OMEGQPF05			5mm
COIL SPRING TRIM PACKER	OMEGQPF10		10mm	
GEARBOX PACKER KIT	GQGK01	1		GQ only
REAR	PART NUMBER	QTY	UNIT PRICE \$	COMMENTS
COILS				
75mm LIFT - MEDIUM	2415	1		290 lbf/in
75mm LIFT - CONSTANT 200KG	3034			300 lbf/in
75mm LIFT - CONSTANT 400KG	3035			470 lbf/in, coil tower reinforcing recommended
100mm LIFT - MEDIUM	2416			290 lbf/in
100mm LIFT - CONSTANT 200KG	3037			300 lbf/in
100mm LIFT - CONSTANT 400KG	3038			470 lbf/in, coil tower reinforcing recommended
125mm LIFT - MEDIUM	2417			290 lbf/in
SHOCKS				
NITROCHARGER SPORT	60015L	2		Suits 75mm & 100mm coils
BP-51 SELECTION				
SHOCK: PATROL GU REAR LONG	BP5160008	2		Suits 75mm & 100mm coils
BP KIT: GU REAR	VM80010023	1		
COMPONENTS				
ADJUSTABLE PANHARD ROD	PANR005	1		Pre 01/00 wagon CC models, RHD & LHD
ADJUSTABLE PANHARD ROD WITH SPH BEARING	PANR029X			01/00 on models not CC, RHD & LHD
SPHERICAL BEARING TO SUIT PANHARD	OME3098			Suits OE and Adjustable 01/00 on
HEAVY DUTY LOWER TRAILING ARMS	LTA3044			Standard Length
ADJUSTABLE UPPER TRAILING ARMS	UTAA106			50mm on car adjustable
TRIM PACKER	OMEGQPR05			5mm
TRIM PACKER	OMEGQPR10			10mm

Notification: Modifications for off - road use only

The products listed in this selection chart are deemed by Old Man Emu to be suitable for off road use and their legality for public road use should be certified by the relevant Registration Authority. An Off Road Use Only Disclaimer must be signed by the customer.

Modifications and replacement of other associated components will be required.

Lift increase is approximate and will depend on vehicle weights.

Warranty Implications

The fitter selling these shocks **must** inform the customer there is **no warranty** due to the severe nature of competition racing. The fitter must also note on the customer's receipt "racing application no warranty applies". This will prevent any future misunderstanding.

PATROL GU Y61 ALL LWB MODELS

FRONT <i>Estimated Lift: 50mm</i>	PETROL 4.5, 4.8 & DIESEL 4.2			DIESEL 2.8 & 3.0 TURBO		
	PART NUMBER	QTY	UNIT PRICE \$	PART NUMBER	QTY	UNIT PRICE \$
SPRING: TO 50 KGS	2970	1		2973	1	
NITROCHARGER SPORT	61012	2		61012	2	
NITROCHARGER	N19			N19		
SPRING: 51 TO 110 KGS	2971	1		2970	1	
NITROCHARGER SPORT	60013	2		60013	2	
NITROCHARGER	N19			N19		
SPRING: 50 KGS: 20mm LIFT	2972	1		2974	1	
NITROCHARGER SPORT	61012	2		61012	2	
NITROCHARGER	N19			N19		
BP-51 SELECTION						
SHOCK PATROL GU FRONT	BP5160005	2		BP5160005	2	
BP KIT PATROL GU FRONT	VM80010022	1		VM80010022	1	
CASTER KIT	OMECA77B 2	1		OMECA77B 2	1	
STEERING DAMPER	OMESD11 5			OMESD11 5		
	OMESD01			OMESD01		
TRIM PACKER	OMEGQPF05 1	1		OMEGQPF05 1	1	
	OMEGQPF10			OMEGQPF10		
OIL PAN PACKER KIT	FK25 2	1		FK25 2	1	
REAR <i>Estimated Lift: 50mm</i>						
	ALL MODELS					
	PART NUMBER	QTY	UNIT PRICE \$			
SPRING: MEDIUM LOAD	2980 4	1				
NITROCHARGER SPORT	61014	2				
NITROCHARGER	N29					
SPRING: CONSTANT 200 KGS	2981 4	1				
NITROCHARGER SPORT	60015	2				
NITROCHARGER	N29					
SPRING: CONSTANT 400 KGS	2985 6	1				
NITROCHARGER SPORT	60015	2				
NITROCHARGER	N29					
SPRING: MEDIUM 30mm LIFT	2982 4	1				
NITROCHARGER SPORT	61014	2				
NITROCHARGER	N29					
BP-51 SELECTION						
SHOCK PATROL GU REAR	BP5160006 7	2				
BP KIT PATROL GU REAR	VM80010023	1				
TRIM PACKER	Do not use Packers					
SWAY BAR EXT KIT	FK18	1				
	FK24 3					

- 5** OMESD11 steering damper fits all Models To 1/2000. OMESD01 fits 2/2000 On Models. To verify correct fitment for individual vehicles compare OE mounts with Steering Stabilisers Specifications on page 166.
- 6** It is highly recommended to reinforce coil towers if fitting heavy rear springs.
- 7** Fitment to vehicle with original exhaust, if larger exhaust fitted some modifications to exhaust may be required.

REMARKS:

- 1** Coil trim packers may be required to trim vehicles. Packers must be installed to the bottom of front coils.
- 2** OMECA77B Caster Kit will increase caster angle by 2°. Check manufacturer's specifications to determine if OMECA77B kit is required. FK25 may be required for some European Models when Caster Kit is fitted.
- 3** FK18: Rear Sway Bar Extension Bracket is **mandatory** fitment to Models with fixed sway bar to prevent damage to sway bar when suspension is at full extension. FK24 suits Models with detachable sway bar.
- 4** **Special Note:** Due to limited clearance between tailshaft and chassis cross member, OME does not recommend fitment of gear box packers.

PATROL GU Y61 SWB MODELS

FRONT <i>Estimated Lift: 40mm</i>	2.8 & 3.0 TURBO DIESEL		
	PART NUMBER	QTY	UNIT PRICE \$
SPRING: TO 50 KGS	2974E	1	
NITROCHARGER SPORT	61012	2	
NITROCHARGER	N19		
SPRING: 51 TO 110 KGS	2972E	1	
NITROCHARGER SPORT	60013	2	
NITROCHARGER	N19		
BP-51 SELECTION			
SHOCK PATROL GU FRONT	BP5160005	2	
BP KIT PATROL GU FRONT	VM80010022	1	
TRIM PACKER	OMEGQPF05		
	OMEGQPF10		
STEERING DAMPER	OMESD01	1	
	OMESD11 ¹		
CASTER KIT	OMECA77B ²		
OIL PAN PACKER KIT	FK25 ³		

REAR <i>Estimated Lift: 40mm</i>	ALL MODELS		
	PART NUMBER	QTY	UNIT PRICE \$
SPRING: LIGHT LOAD	2GQ02A	1	
NITROCHARGER SPORT	61014	2	
NITROCHARGER	N29		
SPRING: MEDIUM LOAD	2GQ02B	1	
NITROCHARGER SPORT	61014	2	
NITROCHARGER	N29		
SPRING: CONSTANT 200 KGS	2GQ02D	1	
NITROCHARGER SPORT	60015	2	
NITROCHARGER	N29		
BP-51 SELECTION			
SHOCK PATROL GU REAR	BP5160006 ⁶	2	
BP KIT PATROL GU REAR	VM80010023	1	
SWAY BAR EXTENSION KIT	FK18	1	
	FK24 ⁴		
GEAR BOX PACKER KIT	GQGK02 ³ ⁵		
TRIM PACKER	OMEGQPR05		
	OMEGQPR10		

REMARKS:

- 1** OMESD01 fits 2/2000 On Models.
OMESD11 fits all Models To 1/2000.
- 2** OMECA77B Caster Kit will increase caster angle by 2°. Check manufacturer's specifications to determine if OMECA77B kit is required.
- 3** FK25 x 2 Oil Pan Kits **must** be installed when OMECA77B Caster Kit or GQGK02 Gear Box Packer Kit are fitted.
- 4** FK18: Rear Sway Bar Extension Bracket is **mandatory** fitment to Models with fixed sway bar to prevent damage to sway bar when suspension is at full extension. FK24 suits Models with detachable sway bar.
- 5** GQGK02 Gear Box Packer Kit is designed to space down the gear box cross member from the chassis to reduce tail shaft flange angle thereby reducing driveline vibration. In some cases two (2) kits may be required.
- 6** Fitment to vehicle with original exhaust, if larger exhaust fitted some modifications to exhaust may be required.

PATROL GU Y61 ALL COIL CAB CHASSIS MODELS

FRONT <i>Estimated Lift: 50mm</i>	ALL 4.2 DIESEL ENGINES			3.0 TURBO DIESEL ENGINE		
	PART NUMBER	QTY	UNIT PRICE \$	PART NUMBER	QTY	UNIT PRICE \$
SPRING: TO 50 KGS	2970	1		2973	1	
NITROCHARGER SPORT	61012	2		61012	2	
NITROCHARGER	N19			N19		
SPRING: 51 TO 110 KGS	2971	1		2970	1	
NITROCHARGER SPORT	60013	2		60013	2	
NITROCHARGER	N19			N19		
BP-51 SELECTION						
SHOCK PATROL GU FRONT	BP5160005	2		BP5160005	2	
BP KIT PATROL GU FRONT	VM80010022	1		VM80010022	1	
STEERING DAMPER	OMESD11	1		OMESD11	1	
CASTER KIT	OMECA77B ¹			OMECA77B ¹		
TRIM PACKER	OMEGQPF05 ²			OMEGQPF05 ²		
	OMEGQPF10 ²			OMEGQPF10 ²		

REAR <i>Estimated Lift: 50mm</i>	ALL MODELS		
	PART NUMBER	QTY	UNIT PRICE \$
SPRING: MEDIUM LOAD	2983	1	
NITROCHARGER SPORT	61014	2	
NITROCHARGER	N29		
SPRING: CONSTANT 200 KGS	2984	1	
NITROCHARGER SPORT	60015	2	
NITROCHARGER	N29		
SPRING: CONSTANT 400 KGS	2985	1	
NITROCHARGER SPORT	60015	2	
NITROCHARGER	N29		
BP-51 SELECTION			
SHOCK PATROL GU REAR	BP5160006 ⁴	2	
BP KIT PATROL GU REAR	VM80010023	1	
SWAY BAR EXTENSION KIT	FK18 ³	1	
TRIM PACKER	Do not use Packers		

REMARKS:

- 1** OMECA77B Caster Kit will increase caster angle by 2°. Check manufacturer's specifications to determine if OMECA77B kit is required.
- 2** Coil trim packers may be required to trim vehicle to a maximum of 15mm. Packers must be installed to the bottom on front coil.
- 3** FK18 Rear Sway Bar Extension Bracket is **mandatory** fitment to prevent damage to sway bar when suspension is at full extension.
- 4** Fitment to vehicle with original exhaust, if larger exhaust fitted some modifications to exhaust may be required.

PATROL GU Y61 CAB CHASSIS

COIL: FRONT / LEAF: REAR

FRONT <i>Estimated Lift: 50mm</i>	ALL 4.2 DIESEL ENGINES			3.0 TURBO DIESEL ENGINE		
	PART NUMBER	QTY	UNIT PRICE \$	PART NUMBER	QTY	UNIT PRICE \$
SPRING: TO 50 KGS	2970	1		2973	1	
NITROCHARGER SPORT	60055	2		60055	2	
NITROCHARGER	N19					
SPRING: 51 TO 110 KGS	2971	1		2970	1	
NITROCHARGER SPORT	60055	2		60055	2	
NITROCHARGER	N19					
STEERING DAMPER	OMESD11	1		OMESD11	1	
CASTER KIT	OMECA77B 2					
TRIM PACKER	OMEGQPF05 1					
	OMEGQPF10 1			OMEGQPF10 1		

REAR <i>Estimated Lift: 50mm</i>	ALL MODELS		
	PART NUMBER	QTY	UNIT PRICE \$
SPRING: MEDIUM LOAD	CS016RA/B 3 4	1 + 1	
NITROCHARGER SPORT	60054	2	
NITROCHARGER	N25		
SPRING: CONSTANT 400 KGS	CS016RA/B 3 4	1 + 1	
NITROCHARGER SPORT	60054	2	
NITROCHARGER	N25		
SPRING BUSH KIT	OMESB64	2	
ANTI INVERSION KIT	FK08 3	1	
GREASABLE SHACKLE KIT	OMEGS1		
GREASABLE SHACKLE FIXED END PIN KIT	OMEGP2		
U BOLT	OMEU64	4	
BRAKE PROPORTIONING BRACKET	FK78	1	
EXTRA LEAF	D15XL	2	
CENTRE BOLT	UCB11		

REMARKS:

- 1 Coil trim packers may be required to trim vehicle to a maximum of 15mm per coil. Packers must be installed to the bottom on front coils.
- 2 OMECA77B Caster Kit will increase caster angle by 2°. Check manufacturer's specifications to determine if OMECA77B kit is required.
- 3 FK08 Anti Inversion Kit is **mandatory** fitment if greasable shackles are not fitted. Refer OME Technical & Fitting Manual.
- 4 For improved ride quality on vehicles carrying medium loads remove the 3rd leaf. Include tray weight in constant load calculation.

PATROL GQ Y60 ALL SWB & LWB MODELS

FRONT <i>Estimated Lift: 40 - 50mm</i>	4.2 ENGINE			2.8 & 3.0 ENGINES		
	PART NUMBER	QTY	UNIT PRICE \$	PART NUMBER	QTY	UNIT PRICE \$
SPRING: TO 50 KGS	2975	1		2974	1	
NITROCHARGER SPORT	61012	2		61012	2	
NITROCHARGER	*N21 / N23F 6			*N21 / N23F 6		
SPRING: 51 TO 110 KGS	2976	1		2972	1	
NITROCHARGER SPORT	60013	2		60013	2	
NITROCHARGER	N21 6			N21 6		
SPRING: 50 KGS: 30mm LIFT	2974	1		NOT APPLICABLE		
NITROCHARGER SPORT	61012	2		-		
NITROCHARGER	*N21 / N23F 6			-		
BP-51 SELECTION			BP-51 SELECTION			
SHOCK PATROL FRONT	BP5160005	2		BP5160005	2	
BP KIT PATROL FRONT	VM80010022	1		VM80010022	1	
TRIM PACKER	OMEGQPF05	1		OMEGQPF05	1	
	OMEGQPF10			OMEGQPF10		
STEERING DAMPER	OMESD36	1		OMESD36	1	
	OMESD34 5			OMESD34 5		
CASTER KIT	OMECA77B 2			OMECA77B 2		

REAR <i>Estimated Lift: 30 - 50mm</i>	LWB MODEL			SWB MODEL		
	PART NUMBER	QTY	UNIT PRICE \$	PART NUMBER	QTY	UNIT PRICE \$
SPRING: LIGHT LOAD	2GQ02C	1		2GQ02CM	1	
NITROCHARGER SPORT	61014	2		61014	2	
SPRING: MEDIUM LOAD	2GQ02AM	1		2GQ02C	1	
NITROCHARGER SPORT	61014	2		61014	2	
NITROCHARGER	N29			N29		
SPRING: CONSTANT 200 KGS	2GQ02J	1		2GQ02G	1	
NITROCHARGER SPORT	60015	2		60015	2	
NITROCHARGER	N29			N29		
LPG CONVERSION			LPG CONVERSION			
SPRING: MEDIUM LOAD	2GQ02LP 4	1		2GQ02LP 4	1	
NITROCHARGER SPORT	61014	2		61014	2	
NITROCHARGER	N29			N29		
BP-51 SELECTION			BP-51 SELECTION			
SHOCK PATROL REAR	BP5160006 7	2		BP5160006 7	2	
BP KIT PATROL REAR	VM80010023	1		VM80010023	1	
TRIM PACKER	Do not use Packers			Do not use Packers		
GEAR BOX PACKER KIT	GQGK01 3	1		GQGK01 3	1	

REMARKS:

- 1 Coil trim packers may be required to trim vehicle to a maximum of 15mm per coil. Packers must be installed to the top on rear coils and to the bottom on front coils.
- 2 OMECA77B Caster Kit will increase caster angle by 2°. Check manufacturer's specifications to determine if OMECA77B kit is required.
- 3 Gearbox Packer Kit is designed to space down the gearbox cross member from the chassis to reduce tail shaft flange angle thereby reducing driveline vibration.
- 4 LPG conversion equated to 100-125 litre rear mounted gas tank and a 70-75 litre mid mounted auxiliary petrol tank.
- 5 OMESD36 fits 8/89 On Models. OMESD34 fits pre 8/89 Models.
- 6 When remaining stock of N21 and N23F is exhausted no further product will be available.
- 7 Fitment to vehicle with original exhaust, if larger exhaust fitted some modifications to exhaust may be required.

PATROL GQ Y60 CAB CHASSIS COIL SPRING MODELS

FRONT <i>Estimated Lift: 50mm</i>	4.2 ENGINES		
	PART NUMBER	QTY	UNIT PRICE \$
SPRING: TO 50 KGS	2975	1	
NITROCHARGER SPORT	61012	2	
NITROCHARGER	N23F 5		
SPRING: 51 TO 110 KGS	2976	1	
NITROCHARGER SPORT	60013	2	
NITROCHARGER	N21 5		
BP-51 SELECTION			
SHOCK PATROL FRONT	BP5160005	2	
BP KIT PATROL FRONT	VM80010022	1	
TRIM PACKER	OMEGQPF05 1		
	OMEGQPF10 1		
STEERING DAMPER	OMESD36	1	
CASTER KIT	OMECA77B 2		

REAR <i>Estimated Lift: 40 - 50mm</i>	ALL MODELS		
	PART NUMBER	QTY	UNIT PRICE \$
SPRING: MEDIUM LOAD 40mm LIFT	2GQ02C 3	1	
NITROCHARGER SPORT	61014	2	
SPRING: CONSTANT 200 KGS	2GQ02J 3	1	
NITROCHARGER SPORT	60015	2	
NITROCHARGER	N29		
BP-51 SELECTION			
SHOCK PATROL REAR	BP5160006 6	2	
BP KIT PATROL REAR	VM80010023	1	
TRIM PACKER	OMEGQPR05 1		
	OMEGQPR10 1		
GEAR BOX PACKER KIT	GQGK01 4	1	

REMARKS:

- 1 Coil trim packers may be required to trim vehicle to a maximum of 15mm per coil. Packers **must** be installed to the top on rear coils and to the bottom on front coils.
- 2 OMECA77B Caster Kit will increase caster angle by 2°. Check manufacturer's specifications to determine if OMECA77B kit is required.
- 3 Include tray weight in constant load calculation.
- 4 Gearbox Packer Kit is designed to space down the gearbox cross member from the chassis to reduce tail shaft flange angle thereby reducing driveline vibration.
- 5 When remaining stock of N21 and N23F is exhausted no further product will be available.
- 6 Fitment to vehicle with original exhaust, if larger exhaust fitted some modifications to exhaust may be required.

PATROL GQ Y60 UTE & CAB CHASSIS LEAF SPRING MODELS

FRONT <i>Estimated Lift: 30mm</i>	4.2 ENGINE		
	PART NUMBER	QTY	UNIT PRICE \$
SPRING: TO 50 KGS	CS003F 1	2	
NITROCHARGER SPORT	60068		
SPRING: 51 TO 110 KGS	CS004F 1	2	
NITROCHARGER SPORT	60068		
SPRING BUSH KIT	OMESB1	2	
GREASABLE SHACKLE KIT	OMEGS2	1	
GREASABLE SHACKLE FIXED END PIN KIT	OMEGP2		
STEERING DAMPER	OMESD22		
CENTRE BOLT SPACER KIT	CBS02 1	2	
EXTRA LEAF	D1XL		
CENTRE BOLT	UCB3		

REMARKS:

- 1** CBS02 x 2 centre bolt spacers required for front spring fitment.
- 2** FK08 Anti Inversion Kit is **mandatory** fitment if greasable shackles are not fitted. Refer OME Technical & Fitting Manual.
- 3** Include tray weight in constant load calculation.
- 4** Remove 3rd leaf for vehicles requiring 400kg constant load springs.

REAR <i>Estimated Lift: 45mm</i>	ALL MODELS		
	PART NUMBER	QTY	UNIT PRICE \$
SPRING: CONSTANT 400 KGS	CS016RA/B 2 3 4	1 + 1	
NITROCHARGER SPORT	60054	2	
NITROCHARGER	N25		
SPRING: CONSTANT 600 KGS	CS016RA/B 2 3	1 + 1	
NITROCHARGER SPORT	60054	2	
NITROCHARGER	N25		
SPRING BUSH KIT	OMESB64	2	
GREASABLE SHACKLE KIT	OMEGS1	1	
GREASABLE SHACKLE FIXED END PIN KIT	OMEGP2		
U BOLTS	OMEU58B	4	
ANTI INVERSION KIT	FK08 2	1	
EXTRA LEAF	D15XL	2	
CENTRE BOLT	UCB11		

PATROL MQ 260 LWB SPANISH BUILT ALL 2.8TD MODELS

FRONT <i>Estimated Lift: 30 - 40mm</i>	PETROL & DIESEL ENGINES		
	PART NUMBER	QTY	UNIT PRICE \$
SPRING: TO 50 KGS	CS016F 1	2	
NITROCHARGER	N19		
SPRING: 51-100 KGS	CS016F	2	
NITROCHARGER	N19		
SPRING BUSH KIT	OMESB3		
	OMESB29		
U BOLTS	OMEU56 2	2	
	OMEU57		
EXTRA LEAF	D30XL		
CENTRE BOLT	UCB17		

REMARKS:

- 1 To improve ride quality remove 3rd leaf from top of spring.
- 2 Front U Bolt:
OMEU56 fits to right hand side.
OMEU57 fits to left hand side.

REAR <i>Estimated Lift: 50mm</i>	ALL MODELS		
	PART NUMBER	QTY	UNIT PRICE \$
SPRING: MEDIUM LOAD	CS011R	2	
NITROCHARGER	N89		
SPRING: CONSTANT 200 KGS	CS012R	2	
NITROCHARGER	*N42 / N89		
SPRING BUSH KIT	OMESB2	2	
	OMESB29		
U BOLTS	OMEU58	4	
EXTRA LEAF	D12XL		
CENTRE BOLT	UCB1	2	

PATROL MQ M60 ALL MODELS

FRONT <i>Estimated Lift: 30 - 40mm</i>	PETROL & DIESEL ENGINES		
	PART NUMBER	QTY	UNIT PRICE \$
SPRING: TO 50 KGS	CS010FA / B 1	1 + 1	
NITROCHARGER	EARLY *N47/N96	2	
	LATE N49		
SPRING: 51 TO 110 KGS	CS011FA / B 1	1 + 1	
NITROCHARGER	EARLY *N47/N96	2	
	LATE N49		
SPRING BUSH KIT	OMESB28 2	2	
	OMESB29		
	OMESB31 2		
	OMESB29		
U BOLTS	OMEU56 4		
	OMEU57		
STEERING DAMPER	OMESD22	1	
EXTRA LEAF	D11XL 5	2	
CENTRE BOLT	UCB5		

REAR <i>Estimated Lift: 50mm</i>	ALL MODELS		
	PART NUMBER	QTY	UNIT PRICE \$
SPRING: MEDIUM LOAD	CS011R	2	
NITROCHARGER	N97		
SPRING: CONSTANT 200 KGS	CS012R	2	
NITROCHARGER	N48		
SPRING BUSH KIT	OMESB2 3	2	
	OMESB29		
U BOLTS	OMEU58	4	
EXTRA LEAF	D12XL	2	
CENTRE BOLT	UCB1		

REMARKS:

- 1 Models with P40 4 litre engine require CS011FA / B springs.
 Individual vehicles fitted with A / B fitment may experience a pronounced trimming problem to right hand side. In these cases fitment of an XL leaf to the right hand side will correct problem.
- 2 Front Spring Bushes:
 Early model (round headlight) require OMESB28 and OMESB29.
 Late model (square headlight) require OMESB31 and OMESB29.
- 3 OME Bush Kits **must** be used to enable springs to be fitted.
- 4 Front U Bolt: OMEU56 fits to right hand side
 OMEU57 fits to left hand side
- 5 D11XL suitable for CS010FA / B.

NAVARA D23 NP300 2015 ON

FRONT <i>Estimated Lift: 20 - 30mm</i>	TWIN TURBO DIESEL			SINGLE TURBO DIESEL		
	PART NUMBER	QTY	UNIT PRICE \$	PART NUMBER	QTY	UNIT PRICE \$
SPRING: No Bar	3099	1		2608	1	
STRUT - SPORT	90032 1	2		90032 1	2	
SPRING: Bar	3100	1		3099	1	
STRUT -SPORT	90032 1	2		90032 1	2	
SPRING: Bar / Winch	3101	1		3100	1	
STRUT -SPORT	90032 1	2		90032 1	2	
UPPER STRUT BUSHES	OME3139 1	2		OME3139 1	2	
STRUT TOP HAT KIT	OMETH005 3			OMETH005 3		
TRIM PACKER	FK84 2			FK84 2		

REAR <i>Estimated Lift: 30mm</i>	COIL SPRING REAR		
	PART NUMBER	QTY	UNIT PRICE \$
SPRING: MEDIUM LOAD	3095	1	
NITROCHARGER SPORT	60136 4	2	
SPRING: CONSTANT 200KG	3096	1	
NITROCHARGER SPORT	*60137 / 60136 4	2	
SPRING: CONSTANT 400KG	3097	1	
NITROCHARGER SPORT	60137 4	2	
SPRING: CONSTANT 600KG	3098	1	
NITROCHARGER SPORT	60137	2	
FITTING KIT - SWAY BAR / BRAKE	FK85	1	

REAR <i>Estimated Lift: 40mm</i>	LEAF SPRING REAR		
	PART NUMBER	QTY	UNIT PRICE \$
SPRING: MEDIUM LOAD	EL092R	2	
NITROCHARGER SPORT	60134		
SPRING: CONSTANT 300KG	EL093R	2	
NITROCHARGER SPORT	*60135 / 60134		
SPRING: CONSTANT 600KG	EL094R	2	
NITROCHARGER SPORT	60135		
GREASABLE SHACKLE KIT	OMEGS24	1	
SPRING BUSH KIT	OMESB114 5	2	
	OMESB115		
U BOLTS	OMEU59A 6	4	
	OMEU59B		
FITTING KIT - BUMP SPACER	FK83 7	1	
EXTRA LEAF	EL43XL 8	2	

REMARKS:

- 1** No top mounting bushes supplied use OME3139. OE bushes may be re-used if in good condition.
- 2** Trim packer FK84 provides approximately 10mm lift at the wheel.
- 3** Stut Top Hat Kit may be required if original equipment is worn.
- 4** Sway Bar/Brake Fitting Kit FK85 is **required** when fitting all OME rear shocks.
- 5** OMESB114 suits OE Shackle. OMESB115 Bush Kit suits OME Greasable Shackle OMEGS24.
- 6** Use OMEU59A when fitting EL092R.

Use OMEU59B when fitting EL093R and EL094R.
- 7** Fitment of Bump Spacer Kit FK83 is **required** when fitting all OME rear leaf springs.
- 8** EL43XL will give approximately 15mm extra lift or increase loading capacity at design height by approximately 300kgs.

NAVARA D40 2005 ON ALL MODELS (USA - NISSAN FRONTIER)

FRONT <i>Estimated Lift: 20 - 30mm</i>	DIESEL & V6 PETROL			V6 TURBO DIESEL		
	PART NUMBER	QTY	UNIT PRICE \$	PART NUMBER	QTY	UNIT PRICE \$
SPRINGS: TO 40 KGS	2607	1		2608	1	
STRUT - SPORT	90003 1	2		90003 1	2	
SPRINGS: 41 TO 80 KGS	2608	1		2631	1	
STRUT - SPORT	90003 1	2		90003 1	2	
UPPER STRUT BUSHES	OME3139 1	2		OME3139 1	2	
STRUT TOP HAT KIT	OMETH005 5			OMETH005 5		

REAR <i>Estimated Lift: 40mm</i>	ALL MODELS		
	PART NUMBER	QTY	UNIT PRICE \$
SPRING: MEDIUM LOAD	CS150R 3	2	
NITROCHARGER SPORT	60017		
NITROCHARGER	N185		
SPRING BUSH KIT	OMESB99	2	
	OMESB100 2		
SPRING: CONSTANT 400 KGS	CS151R 3	2	
NITROCHARGER SPORT	*60110 / 60017		
NITROCHARGER	N185		
SPRING BUSH KIT	OMESB99		2
	OMESB100 2		
GREASABLE SHACKLE KIT	OMEGS15 2	1	
U BOLTS	OMEU53A 4	4	
EXTRA LEAF	D31XL	2	
CENTRE BOLT	UCB19		

REMARKS:

- 1 No top mounting bushes supplied, use OME3139. OE bushes may be re-used if in good condition.
- 2 Use: OME3139 with OE Shackles. OME3139 when installing OMEGS15.
- 3 Include tray weight in constant load calculation.
- 4 OE U bolt plate bolt holes may need to be enlarged when fitting OME U bolts.
- 5 Strut Top Hat Kit may be required if original equipment is worn.

NAVARA D22 10/2002 ON ALL MODELS NP300 2008 TO 2014 ALL MODELS

FRONT	PART NUMBER	QTY	UNIT PRICE \$
TORSION BARS: OVER 50 KGS	303007 1	1	
NITROCHARGER SPORT	60034 2	2	

REMARKS:

- 1 Raise or lower front end clearance and trim vehicle by adjusting front torsion bars. **Important:** A minimum of 60mm of droop **must** be maintained.
- 2 It may be necessary to slightly increase the clearance in the front wishbone to allow shock absorber to fit. Do not modify shock absorber.
- 3 Include tray weight in constant load calculation. For constant 400kg loads, add D18XL to CS031R.
- 4 CS032R has a 25mm lower cambered 2nd stage for improved ride quality, however under heavy load this will cause the ride height to be 25mm lower.
- 5 FK01 U Bolt Thread Spacer Kit required on all cab chassis Models. OME3139 suits OE Shackle.
- 6 OME3139 suits OME Greasable Shackle OMEGS21.

REAR <i>Estimated Lift: 30mm</i>	ALL MODELS		
	PART NUMBER	QTY	UNIT PRICE \$
SPRING: MEDIUM LOAD	CS032R 4	2	
NITROCHARGER SPORT	60035		
SPRING: CONSTANT 200 KGS	CS031R 3	2	
NITROCHARGER SPORT	60035		
NITROCHARGER	N59		
SPRING BUSH KIT	OMESB91	2	
	OMESB105 6		
U BOLTS	OMEU63	4	
U BOLT THREAD SPACER KIT	FK01 5	1	
GREASABLE SHACKLE KIT	OMEGS21 6	1	
EXTRA LEAF	D18XL 3	2	
CENTRE BOLT	UCB14		

NAVARA D21 & D22 TO 8/2002 ALL MODELS

FRONT	PART NUMBER	QTY	UNIT PRICE \$
TORSION BARS: OVER 50 KGS	303007 1	1	
	303008		
NITROCHARGER SPORT	60021 2	2	
STEERING DAMPER	OMESD35 3	1	

REMARKS:

1 Raise or lower front end clearance and trim vehicle by adjusting front torsion bars. 303007 suits D22 & 303008 suits D21 Models.

Important: A minimum of 60mm of droop **must** be maintained.

2 It may be necessary to slightly increase the clearance in the front wishbone to allow shock absorber to fit. Do not modify shock absorber.

3 On later Models steering damper was not fitted. Check vehicle to confirm it does have an original steering damper fitted.

4 For constant 400kg loads, add D18XL to CS031R. Include tray weight in constant load calculation.

REAR <i>Estimated Lift: 30mm</i>	ALL MODELS		
	PART NUMBER	QTY	UNIT PRICE \$
SPRING: MEDIUM LOAD	CS030R	2	
NITROCHARGER SPORT	60035		
SPRING: CONSTANT 200 KGS	CS031R 4	2	
NITROCHARGER SPORT	60035		
NITROCHARGER	N59		
SPRING BUSH KIT	OMESB81	2	
U BOLTS	OMEU63	4	
EXTRA LEAF	D18XL 4	2	
CENTRE BOLT	UCB14		

PATHFINDER R51 2005 TO 2014 (NOT USA MANUFACTURED MODEL)

FRONT <i>Estimated Lift: 30mm</i>	DIESEL & V6 PETROL			V6 TURBO DIESEL		
	PART NUMBER	QTY	UNIT PRICE \$	PART NUMBER	QTY	UNIT PRICE \$
SPRING: TO 40 KGS	2607	1		2608	1	
STRUT - SPORT	90003 1	2		90003 1	2	
SPRING: 41 TO 100 KGS	2608	1		2631	1	
STRUT - SPORT	90003 1	2		90003 1	2	
UPPER STRUT BUSHES	OME3139 1	2		OME3139 1	2	
STRUT TOP HAT KIT	OMETH005 2			OMETH005 2		

REMARKS:

1 A 4 Wheel alignment **must** be carried out after fitment of OME suspension. No top mounting bushes supplied, use OME3139. OE bushes may be re-used if in good condition.

2 Strut Top Hat Kit may be required if original equipment is worn.

REAR <i>Estimated Lift: 30mm</i>	ALL MODELS		
	PART NUMBER	QTY	UNIT PRICE \$
SPRING: MEDIUM LOAD	2609	1	
NITROCHARGER SPORT	60016	2	
SPRING: CONSTANT 200 KGS	2610	1	
NITROCHARGER SPORT	60016	2	

PATHFINDER R50 1996 TO 2005 V6 MODELS

FRONT <i>Estimated Lift: 15mm</i>	V6 MODEL		
	PART NUMBER	QTY	UNIT PRICE \$
SPRING: NO ACCESSORIES	2921	1	
SPRING: TO 50 KGS	2923		
SPRING: 51 TO 100 KGS	2928		
STRUT	N145S + N146S 2 3	1+1	
FITTING KIT	SMP638 2	1	

REAR <i>Estimated Lift: 20mm</i>	ALL MODELS		
	PART NUMBER	QTY	UNIT PRICE \$
SPRING: MEDIUM LOAD	2922	1	
NITROCHARGER	N61	2	
	N104 1		

REMARKS:

- 1** N61: Suit Models To 1/99. N104: Suit Models from 2/99 On.
- 2** Vehicles with ABS will require ABS Bracket Kit SMP638.
- 3** N146S Right Hand Side x 1
N145S Left Hand Side x 1
No top mounting bushes supplied, re-use OE bushes.

PATHFINDER TO LATE 1995 ALL MODELS

FRONT			
	PART NUMBER	QTY	UNIT PRICE \$
TORSION BARS	- 1		
NITROCHARGER SPORT	60031 2	2	
STEERING DAMPER	OMESD35	1	

REAR <i>Estimated Lift: 20mm</i>	ALL MODELS		
	PART NUMBER	QTY	UNIT PRICE \$
SPRING: MEDIUM LOAD	2920	1	
NITROCHARGER SPORT	*60064 / 60032	2	
NITROCHARGER	*N42 / N89		

REMARKS:

- 1** Raise or lower front end clearance and trim vehicle by adjusting front torsion bars.
Important: A minimum of 60mm of drop **must** be maintained.
- 2** It may be necessary to slightly increase the clearance in the front wishbone to allow shock absorber to fit. Do not modify shock absorber.

TERRANO II R20 1996 TO 2005

FRONT	PETROL & DIESEL ENGINES		
	PART NUMBER	QTY	UNIT PRICE \$
TORSION BARS	- 1		
NITROCHARGER SPORT	60031 2	2	

REAR <i>Estimated Lift: 20mm</i>	ALL MODELS		
	PART NUMBER	QTY	UNIT PRICE \$
SPRING: MEDIUM LOAD	2920	1	
NITROCHARGER SPORT	60058	2	

REMARKS:

- 1** Raise or lower front end clearance and trim vehicle by adjusting front torsion bars.
- 2** It may be necessary to slightly increase the clearance in the front wishbone to allow shock absorber to fit. Do not modify shock absorber.

XTERRA 2005 ON MODELS

FRONT <i>Estimated Lift: 30mm</i>	V6 PETROL ENGINE		
	PART NUMBER	QTY	UNIT PRICE \$
SPRINGS: TO 40 KGS	2607	1	
STRUT - SPORT	90003 1	2	
SPRINGS: 41 TO 80 KGS	2608	1	
STRUT - SPORT	90003 1	2	
UPPER STRUT BUSHES	OME3139 1		
STRUT TOP HAT KIT	OMETH005 5		

REAR <i>Estimated Lift: 30mm</i>	ALL MODELS		
	PART NUMBER	QTY	UNIT PRICE \$
SPRING: MEDIUM LOAD	CS061R 4	2	
NITROCHARGER SPORT	60017 3		
NITROCHARGER	N185		
SPRING BUSH KIT	OMESB99 2	2	
	OMESB100		
GREASABLE SHACKLE KIT	OMEGB15 2	1	
U BOLTS	OMEU72	4	
FITTING KIT	FK42 3	1	
EXTRA LEAF	D37XL 4	2	

REMARKS:

- 1 No top mounting bushes supplied, use OME3139. OE bushes may be re-used if in good condition.
- 2 OMESB99 suits factory shackles.
OMESB100 suits OMEGB15 Greasable Shackle Kit.
- 3 FK42 is a **mandatory** fitment to space sway bar link away from shock absorber.
- 4 CS061R with D37XL provides approximately 60mm lift over factory with no additional rear load.
CS061R with D37XL provides approximately 30mm lift over factory with constant 200kg additional rear load.
- 5 Strut Top Hat Kit may be required if original equipment is worn.

SSANGYONG

MUSSO, SPORT UTILITY & KORANDO 1995 TO 2005

FRONT	PETROL & DIESEL ENGINES		
	PART NUMBER	QTY	UNIT PRICE \$
TORSION BARS	-		
NITROCHARGER SPORT	60031	2	

REAR	ALL MODELS		
	PART NUMBER	QTY	UNIT PRICE \$
<i>Estimated Lift: 40mm</i>			
SPRING: MEDIUM LOAD	2937	1	
NITROCHARGER	N118	2	

SUZUKI

GRAND VITARA 8/2005 TO 2015

FRONT	PETROL V6 (2.7) (3.2) DIESEL (1.9)			PETROL 4 CYLINDER (2.0)		
	PART NUMBER	QTY	UNIT PRICE \$	PART NUMBER	QTY	UNIT PRICE \$
<i>Estimated Lift: 20mm</i>						
SPRING: TO 35 KGS	2623	1		2624	1	
STRUT	N217S + N218S ¹	1 + 1		N217S + N218S ¹	1 + 1	

REAR	ALL MODELS		
	PART NUMBER	QTY	UNIT PRICE \$
<i>Estimated Lift: 20mm</i>			
SPRING: MEDIUM LOAD	2625	1	
NITROCHARGER	OME036	2	

REMARKS:

- ¹ N217S Left Hand Side.
N218S Right Hand Side.

GRAND VITARA TO 2005

FRONT	PETROL 4 & 6 CYLINDER ENGINE			DIESEL ENGINE		
	PART NUMBER	QTY	UNIT PRICE \$	PART NUMBER	QTY	UNIT PRICE \$
<i>Estimated Lift: 30mm</i>						
SPRING: TO 35 KGS	2959	1		2962	1	
STRUT	N103S	2		N103S	2	
SPRING: 36 TO 75 KGS	2962	1		2962 ¹	1	
STRUT	N103S	2		N103S	2	
COIL PACKER	OMESJR10			OMESJR10		

REAR	ALL MODELS		
	PART NUMBER	QTY	UNIT PRICE \$
<i>Estimated Lift: 30mm</i>			
SPRING: MEDIUM LOAD	2961	1	
NITROCHARGER	N105	2	

REMARKS:

- ¹ Coil packer OMESJR10 can be used to increase ride height.

VITARA WAGON 1988 TO 2005

FRONT <i>Estimated Lift: 25 - 30mm</i>	V6 PETROL ENGINE		
	PART NUMBER	QTY	UNIT PRICE \$
SPRING: TO 35 KGS	2950	1	
STRUT	N103S	2	
SPRING: 36 TO 75 KGS	2959	1	
STRUT	N103S	2	

REAR <i>Estimated Lift: 30mm</i>	ALL MODELS		
	PART NUMBER	QTY	UNIT PRICE \$
SPRING: LIGHT LOAD	2954	1	
NITROCHARGER	N105	2	
SPRING: MEDIUM LOAD	2955	1	
NITROCHARGER	N105	2	

VITARA WAGON 1988 TO 2005

FRONT <i>Estimated Lift: 30mm</i>	4 CYLINDER PETROL ENGINE		
	PART NUMBER	QTY	UNIT PRICE \$
SPRING: TO 35 KGS	2960	1	
STRUT	N103S	2	
SPRING: 36 TO 75 KGS	2953	1	
STRUT	N103S	2	

REAR <i>Estimated Lift: 30mm</i>	ALL MODELS		
	PART NUMBER	QTY	UNIT PRICE \$
SPRING: LIGHT LOAD	2954	1	
NITROCHARGER	N105	2	
SPRING: MEDIUM LOAD	2955	1	
NITROCHARGER	N105	2	

VITARA SWB TO 2005

FRONT <i>Estimated Lift: 30mm</i>	4 CYLINDER PETROL ENGINE		
	PART NUMBER	QTY	UNIT PRICE \$
SPRING: TO 35 KGS	2951	1	
STRUT	N103S 1	2	

REAR <i>Estimated Lift: 30mm</i>	ALL MODELS		
	PART NUMBER	QTY	UNIT PRICE \$
SPRING: MEDIUM LOAD	2952	1	
NITROCHARGER	N32 2	2	

REMARKS:

- 1** Front strut has 40mm longer travel than original equipment.
- 2** Rear shock has 50mm longer travel than original equipment.

XL7 WAGON 2001 TO 2005

FRONT <i>Estimated Lift: 25mm</i>	PETROL ENGINE			DIESEL ENGINE		
	PART NUMBER	QTY	UNIT PRICE \$	PART NUMBER	QTY	UNIT PRICE \$
SPRING: NO ACCESSORIES	2956	1		2962	1	
STRUT	N103S	2		N103S	2	
BUMP STOP SPACER KIT	FK28	1		FK28	1	

REAR <i>Estimated Lift: 35mm</i>	ALL MODELS		
	PART NUMBER	QTY	UNIT PRICE \$
SPRING: MEDIUM LOAD	2968	1	
NITROCHARGER	N105	2	

REMARKS:

- 1** FK28 Bump Stop Spacer Kit is a **mandatory** fitment with N103S Struts.

EQUATOR (US MARKET ONLY)

FRONT <i>Estimated Lift: 30mm</i>	DIESEL & V6 PETROL		
	PART NUMBER	QTY	UNIT PRICE \$
SPRINGS: TO 40 KGS	2607	1	
STRUT - SPORT	90003	2	
SPRINGS: 41 TO 80 KGS	2608	1	
STRUT - SPORT	90003	2	
UPPER STRUT BUSHES	OME3139		
STRUT TOP HAT KIT	OMETH005	4	

REAR <i>Estimated Lift: 40mm</i>	ALL MODELS		
	PART NUMBER	QTY	UNIT PRICE \$
SPRING: MEDIUM LOAD	CS150R	2	
NITROCHARGER SPORT	60017	2	
NITROCHARGER	N185		
SPRING BUSH KIT	OMESB99 OMESB100		2
SPRING: CONSTANT 400 KGS	CS151R	2	
NITROCHARGER SPORT	60017	2	
NITROCHARGER	N185		
SPRING BUSH KIT	OMESB99 OMESB100		2
GREASABLE SHACKLE KIT	OMECS15	1	
U BOLTS	OMEU53A	4	

REMARKS:

- 1** OE plastic stone shield **must** be refitted. No top mounting bushes supplied, use OME3139. OE bushes may be re-used if in good condition.
- 2** Use: OMESB99 with OE Shackles.
OMESB100 when installing OMECS15.
- 3** OE U Bolt plate bolt holes may need to be enlarged when fitting OME U Bolts.
- 4** Strut Top Hat Kit may be required if original equipment is worn.

SIERRA / SAMURAI ALL LEAF SPRING MODELS (SJ413)

STD TRACK : 1984 - 1988

SJ50 - SWB

SJ51 - LWB

WIDE TRACK : 1988 - 1996

SJ70 - SWB (also fits MG410)

SJ71 - LWB (also fits MG410WT)

Note: MG410 & MG10WT are Indian built LWB Models.

FRONT <i>Estimated Lift: 40mm</i>	1.0 LITRE			1.3 LITRE		
	PART NUMBER	QTY	UNIT PRICE \$	PART NUMBER	QTY	UNIT PRICE \$
SPRING: TO 25 KGS	CS012FA / B [5]	1 + 1		CS012FA / B [5]	1 + 1	
NITROCHARGER	OME015	2		OME025	2	
SPRING: 26 TO 75 KGS	CS013FA / B [5]	1 + 1		CS013FA / B [5]	1 + 1	
NITROCHARGER	OME025	2		OME025	2	
SPRING BUSH	OMESB19	2		OMESB19	2	
	OMESB25 [1]			OMESB25 [1]		
U BOLTS	Required [3]	4		Required [3]	4	
FITTING KIT	FK06 [4]	1		FK06 [4]	1	
TRIM PACKER	TP05			TP05		
STEERING DAMPER	OMESD30	1		OMESD30	1	
EXTRA LEAF	D20XL [6]	2		D20XL [6]	2	
CENTRE BOLT	UCB7			UCB7		

REAR <i>Estimated Lift: 40mm</i>	ALL MODELS		
	PART NUMBER	QTY	UNIT PRICE \$
SPRING: MEDIUM LOAD	CS038R	2	
NITROCHARGER	OME013 [2] N43		
SPRING: CONSTANT 100 KGS	CS039R	2	
NITROCHARGER	OME013 [2] N43		
SPRING BUSH KIT	OMESB19	2	
	OMESB25 [1]		
U BOLTS	Required [3]	4	
TRIM PACKER	TP05		
EXTRA LEAF	D21XL	2	
CENTRE BOLT	UCB7		

REMARKS:

- 1** OMESB19 Bush Kit fits all Models except LJ50. OMESB25 Bush Kit only fits Model LJ50.
- 2** OME013 fits all Models except LJ80 and LJ80 II. N43 fits all LJ80 and LJ80 II Models.
- 3** **88 To '96 1300cc Wide Track Models:**
 Front: D/S OMEU61 x 1, OMEU61B x 1 P/S OMEU60 x 2
 Rear: OMEU60 x 4

84 To '88 1300cc STD Track Models:
 Front: D/S OMEU61 x 1, OMEU61B x 1 P/S OMEU62 x 2
 Rear: OMEU62 x 4

81 To '87 1000cc Models:
 Front: D/S OMEU61 x 1, OMEU61B x 1 P/S OMEU60 x 2
 Rear: OMEU60 x 4
- 4** FK06 kit required for Model with OE stabiliser bar. Refer OME Technical & Fitting Manual.
- 5** **IMPORTANT:** Sierras used in extreme heavy off road conditions eg., station mustering, must have CS013FA + B installed.
- 6** D20XL is suitable for CS012FA / B.

SANTANA SAMURAI TO 2004 SWB & LWB MODELS

FRONT <i>Estimated Lift: 30 - 40mm</i>	1.3 LITRE PETROL			1.9 LITRE DIESEL		
	PART NUMBER	QTY	UNIT PRICE \$	PART NUMBER	QTY	UNIT PRICE \$
SPRING: TO 25 KGS - 40mm	CS012FA / B [2]	1 + 1		CS013FA / B [2]	1 + 1	
NITROCHARGER	OME034	2		OME034	2	
SPRING: 26 TO 75 KGS	CS013FA / B [2] [1]	1 + 1		CS013FA / B [2] [1]	1 + 1	
XL LEAF	D20XL			D20XL		
NITROCHARGER	OME034	2		OME034	2	
SPRING BUSH	OMESB19	2		OMESB19	2	
U BOLTS	OE			OE		
	OMEU60 [2] OMEU61	2+2		OMEU60 [2] OMEU61	4	
	LHS RHS			LHS RHS		
CENTRE BOLT	UCB7	2		UCB7	2	
STEERING DAMPER	OMESD30 [3]	1		OMESD30 [3]	1	
TRIM PACKER	TP05			TP05		

REAR <i>Estimated Lift: 40mm</i>	SWB MODEL			LWB MODEL		
	PART NUMBER	QTY	UNIT PRICE \$	PART NUMBER	QTY	UNIT PRICE \$
SPRING: MEDIUM LOAD	CS038R [2]	2		CS039R [2]	2	
NITROCHARGER	OME035			OME035		
SPRING: CONSTANT 100KGS	CS039R [2]	2		CS039R [2] [4]	2	
XL LEAF	-			D21XL		
NITROCHARGER	OME035	2		OME035		
SPRING BUSH KIT	OMESB19	2		OMESB19	2	
U BOLTS	OE			OE		
	OMEU60 [2]	4		OMEU60 [2]	4	
CENTRE BOLT	-			UCB7	2	
TRIM PACKER	TP05			TP05		

REMARKS:

- Fitment of XL Leaf D20XL is recommended for weight in excess of 26kg on diesel Model and 75kg on petrol Model.
- Front: LHS: OMEU60 x 2, RHS: OMEU61B x 2 required when fitting CS013FA/B
Rear: OMEU60 x 4 required when fitting CS039R
- OMESD30 can be fitted to Models which have an OE steering damper.
- Fitment of XL leaf D21XL is recommended for LWB Models with constant 100kg rear weight or OE hard top.

JIMNY SN413

FRONT <i>Estimated Lift: 40mm</i>	4 CYLINDER PETROL ENGINE			DIESEL ENGINE		
	PART NUMBER	QTY	UNIT PRICE \$	PART NUMBER	QTY	UNIT PRICE \$
SPRING: TO 35 KGS	2963	1		2965	1	
NITROCHARGER	OME028	2		OME028	2	
SPRING: 36 TO 85 KGS	2965	1		2969	1	
NITROCHARGER	OME028	2		OME028	2	

REAR <i>Estimated Lift: 40mm</i>	ALL MODELS		
	PART NUMBER	QTY	UNIT PRICE \$
SPRING:	2966 [1] 2967	1	
NITROCHARGER	OME029	2	
TRIM PACKER	OMESJR10		

REMARKS:

- 2966 suits right hand drive Models with a 20mm higher right hand side coil.
2967 suits left hand drive Models with equal height coils.
If uncertain, compare original coil heights.

LANDCRUISER 200 SERIES WAGON*

** DOES NOT SUIT AHC MODELS **

FRONT <i>Estimated Lift: As Below</i>	ALL V8 DIESEL ENGINES			V8 PETROL ENGINE		
	PART NUMBER	QTY	UNIT PRICE \$	PART NUMBER	QTY	UNIT PRICE \$
SPRING: NO WEIGHT: 25mm LIFT	2700	1		2704	1	
STRUT - SPORT	90017	2		90017	2	
STRUT	N208S	1		N208S	1	
SPRING: 100 KGS: 25mm LIFT	2701	1		2705	1	
STRUT - SPORT	91005	2		91005	2	
STRUT	N208S	1		N208S	1	
SPRING: NO WEIGHT: 50mm LIFT	2702	1		2700	1	
STRUT - SPORT	90017	2		90017	2	
STRUT	N208S	1		N208S	1	
SPRING: 100 KGS: 50mm LIFT	2703	1		2701	1	
STRUT - SPORT	91005	2		91005	2	
STRUT	N208S	1		N208S	1	
UPPER STRUT BUSHES	OME3125	2		OME3125	2	
COIL PACKER	OME95PF5	3		OME95PF5	3	
STRUT TOP HAT KIT	OMETH003	2		OMETH003	2	
BP-51 SELECTION - ALL MODELS						
COIL OVER LC200 FRONT LH	BP5190003L	1		SELECTION HINTS: *For Fitment to Models with Toyota's KDSS (Kinetic Dynamic Suspension System) fitted, please refer to OME's Fitting Hints & Tips (OME Bulletin 70 LC200 KDSS Fitting Hints).		
COIL OVER LC200 FRONT RH	BP5190003R					
BP KIT LC200 FRONT	VM80010003					
REAR <i>Estimated Lift: As Below</i>	ALL MODELS					
PART NUMBER	QTY	UNIT PRICE \$				
SPRING: MEDIUM LOAD: LESS 20mm	2720	1				
NITROCHARGER SPORT	61029	2				
NITROCHARGER	N209					
SPRING: MEDIUM LOAD: NO LIFT	2721	1				
NITROCHARGER SPORT	61029	2				
NITROCHARGER	N209					
SPRING: MEDIUM LOAD: 20mm LIFT	2722	1				
NITROCHARGER SPORT	61029	2				
NITROCHARGER	N209					
SPRING: CONSTANT 200 KGS: 20mm	2723	1				
NITROCHARGER SPORT	61030	2				
SPRING: CONSTANT 400 KGS: 20mm	2724	1				
NITROCHARGER SPORT	61030	2				
SPRING: CONSTANT 600 KGS: 20mm	2725	1				
NITROCHARGER SPORT	61030	2				
TRIM PACKER	OME80PR05					
	OME80PR10					
STONE GUARD KIT	OME661	1				
SWAY BAR UPGRADE (33mm)	OMESTAB5	1				
BP-51 SELECTION						
SHOCK LC200 REAR	BP5160026	2		REMARKS: 1 OME coils and strut can only be installed together due to different winding of the lower coil end to suit the OME coil seat. They are not compatible with the OE Coil Seat. Due to the nature of the KDSS, Models fitted with KDSS may experience a characteristic 10mm to 15mm lean to the front right hand side. 2 No top mounting bushes supplied use OME3125. OE bushes may be re-used if in good condition. 3 To maintain ride height when front accessory weight exceeds 100kgs, OME95PF5 coil packer should be installed, each OME95PF5 will increase ride height by 10mm. 4 OME661 Lower Shock Stone Guards are recommended fitment for protection against stone damage. 5 Not suitable for KDSS Models. 6 Strut Top Hat Kit may be required if original equipment is worn.		
BP KIT LC200 REAR	VM80010004	1				
BP KIT LC200 KDSS REAR	VM80010005					

ARMoured APPLICATION 4.5T is available refer to page 20 for details

LANDCRUISER 100 SERIES INDEPENDENT FRONT SUSPENSION

**** DOES NOT SUIT AHC MODELS ****

FRONT	PETROL & DIESEL ENGINES		
	PART NUMBER	QTY	UNIT PRICE \$
TORSION BARS: OVER 75 KGS	303001	1	
	303002		
NITROCHARGER SPORT	*60001 / 60000	2	
NITROCHARGER	N133		
FITTING KIT	FK27	1	

REMARKS:

1 Raise or lower front end clearance and trim vehicle by adjusting front torsion bars. It is **important** that a minimum of 60mm of droop is maintained to prevent topping out of the front shock absorbers. 303001 suits V8 Models. 303002 suits Turbo Diesel Models.

NB: In some Middle Eastern Countries, 6 Cylinder Petrol LandCruiser 100 Series (IFS) use the longer turbo diesel torsion bars.

REAR <i>Estimated Lift: 10mm</i>	ALL MODELS 10/2000 ON		
	PART NUMBER	QTY	UNIT PRICE \$
SPRING: MEDIUM LOAD	2860	1	
NITROCHARGER SPORT	60002	2	
NITROCHARGER	N101		
SPRING: CONSTANT 200 KGS	2863	1	
NITROCHARGER SPORT	*60003 / 60002	2	
NITROCHARGER	N101		
SPRING: CONSTANT 400 KGS	2864	1	
NITROCHARGER SPORT	60003	2	
SPRING: MEDIUM LOAD	2866		
NITROCHARGER SPORT	2862	1	
	60002		
NITROCHARGER	N101	2	
	OME80PR05		
TRIM PACKER	OME80PR10		
	OME661		
STONE GUARD KIT	OME662	1	

2 Packers must be installed on top of coils.

3 SPORT/NITROCHARGER FITMENT: OME661 or OME662 (suits 40mm diameter control arms). Lower Shock Mount Stone Guard is recommended fitment to rear shocks to protect against severe stone peppering encountered on loose road

4 Original rear rake is 60mm approximately with OE coil rates of 145lbs/in or 25.5N/mm. Customers wishing to lower the rear height but increase the load carrying ability can select from:

2866 - Reduces OE height by 10mm (rates 240 - 300lbs/in, 42 - 52.5N/mm)

2862 - Reduces OE height by 30mm (rates 240lbs/in, 42N/mm)

5 Due to the common problem of the lower control arm cracking when driven under hard conditions, the fitment of a FK27 Lower Control Arm Reinforcing Bracket Kit is strongly recommended.

REAR <i>Estimated Lift: 40mm</i>	10/98 TO 2000 V8 MODELS		
	PART NUMBER	QTY	UNIT PRICE \$
SPRING: MEDIUM LOAD	2865	1	
NITROCHARGER SPORT	60002	2	
NITROCHARGER	N101		
SPRING: CONSTANT 200 KGS	2866	1	
NITROCHARGER SPORT	*60003 / 60002	2	
NITROCHARGER	N101		
TRIM PACKER	OME80PR05		
	OME80PR10		
STONE GUARD KIT	OME661	1	
	OME662		

LANDCRUISER 105 SERIES & 80 SERIES WAGONS LIVE AXLE FRONT SUSPENSION MODELS

FRONT <i>Estimated Lift: 10 - 50mm</i>	PETROL & DIESEL ENGINES			PETROL & DIESEL ENGINES		
	PART NUMBER	QTY	UNIT PRICE \$	PART NUMBER	QTY	UNIT PRICE \$
SPRING: TO 50 KGS - 50mm	2851	1		BP-51 SELECTION - Lift To 50mm		
NITROCHARGER SPORT	60018	2		BP5160012	2	
NITROCHARGER	N73			VM80010025 BP KIT	1	
SPRING: 51 TO 110 KG - 50mm	2850	1				
NITROCHARGER SPORT	*60070 / 60018	2				
NITROCHARGER	N73					
SPRING: TO 110 KGS - 10mm	2861	1				
NITROCHARGER SPORT	60070	2				
NITROCHARGER	N73					
TRIM PACKER	OME80PF05					
	OME80PF10					
STEERING DAMPER	OMESD24	1				
CASTER KIT	OMECA77B					

REAR <i>Estimated Lift: 20 - 50mm</i>	ALL MODELS			ALL MODELS & LPG		
	PART NUMBER	QTY	UNIT PRICE \$	PART NUMBER	QTY	UNIT PRICE \$
SPRING: MEDIUM LOAD	2860	1		BP-51 SELECTION - Lift To 50mm		
NITROCHARGER SPORT	60020	2		BP5160013	2	
NITROCHARGER	N74E			VM80010026 BP KIT	1	
SPRING: CONSTANT 200 KGS	2863	1				
NITROCHARGER SPORT	60020	2				
NITROCHARGER	N74E					
SPRING: CONSTANT 400 KGS	2864	1				
NITROCHARGER SPORT	60071	2				
NITROCHARGER	N74E					
SPRING: CONSTANT 600 KGS	2868	1				
NITROCHARGER SPORT	60071	2				
NITROCHARGER	N74E					
SPRING: MEDIUM 20mm LIFT	2862	1				
NITROCHARGER SPORT	60020	2				
NITROCHARGER	N74E					
TRIM PACKER	OME80PR05					
	OME80PR10					
STONE GUARD KIT	OME661	1				
	OME662					

REAR <i>Estimated Lift: 50mm</i>	LPG CONVERSION		
	PART NUMBER	QTY	UNIT PRICE \$
SPRING: MEDIUM LOAD	2860	1	
NITROCHARGER SPORT	60020	2	
NITROCHARGER	N74E		
SPRING: CONSTANT 200 KGS	2863	1	
NITROCHARGER SPORT	60020	2	
NITROCHARGER	N74E		
TRIM PACKER	OME80PR05		
	OME80PR10		
STONE GUARD KIT	OME661	1	
	OME662		

REMARKS:

- 1** OMECA77B Caster Kit will increase caster angle by 2°. Check manufacturer's specifications to determine if OMECA77B kit is required.
- 2** Packers must be installed on the top of coil springs.
- 3** OME662 or OME661 Lower Shock Mount Stone Guard is recommended fitment to protect against severe stone peppering encountered on loose road surfaces. OME662 will only fit Models with 34mm diameter control arms.

OFF ROAD USE ONLY - TOYOTA

LANDCRUISER 80 & 105 SERIES

FRONT	PART NUMBER	QTY	UNIT PRICE	COMMENTS
COILS				
75mm LIFT - SPRING TO 50KG	2418	1		300 lbf/in
75mm LIFT - SPRING 51 TO 110KG	3039			220 lbf/in
100mm LIFT - SPRING TO 50KG	2419			300 lbf/in
100mm LIFT - SPRING 51 TO 110KG	3051			220 lbf/in
125mm LIFT - SPRING TO 50KG	2420			300 lbf/in
SHOCKS				
NITROCHARGER SPORT	60018L	2		Suits 75mm & 100mm coils
NITROCHARGER SPORT	60070L			Suits 75mm & 100mm coils
BP-51 SELECTION				
SHOCK: LC80/105 FRONT LONG	BP5160014	2		Suits 75mm & 100mm coils
BP KIT: LC80/105 FRONT	VM80010025	1		
STEERING DAMPER				
STABILISER	OMESD24	1		
COMPONENTS				
ADJUSTABLE PANHARD ROD	PANR007	1		RHD only
	PAN3050			LHD only
COIL SPRING TRIM PACKER	OME80PF05			5mm
COIL SPRING TRIM PACKER	OME80PF10			10mm
REAR	PART NUMBER	QTY	UNIT PRICE	COMMENTS
COILS				
75mm LIFT - MEDIUM	2421	1		280 lbf/in
75mm LIFT - CONSTANT 200KG	3040			250 lbf/in
75mm LIFT - CONSTANT 400KG	3049			320 lbf/in
100mm LIFT - MEDIUM	2422			280 lbf/in
100mm LIFT - CONSTANT 200KG	3043			250 lbf/in
100mm LIFT - CONSTANT 400KG	3052			320 lbf/in
125mm LIFT - MEDIUM	2423			280 lbf/in
SHOCKS				
NITROCHARGER SPORT	60020L	2		Suit 75mm & 100mm coils
NITROCHARGER SPORT	60071L			Suit 75mm & 100mm coils
BP-51 SELECTION				
SHOCK: LC80/105 REAR LONG	BP5160015	2		Suits 75mm & 100mm Coils
BP KIT: LC80/105 REAR	VM80010026	1		
COMPONENTS				
ADJUSTABLE PANHARD ROD	PANR008	1		RHD & LHD
HEAVY DUTY LOWER TRAILING ARMS	LTA3043			Standard Length
ADJUSTABLE UPPER TRAILING ARMS	UTA3036			40mm on car adjustable
TRIM PACKER	OME80PR05			5mm, MUST be installed top of coil
	OME80PR10		10mm, MUST be installed top of coil	

Notification: Modifications for off - road use only

The products listed in this selection chart are deemed by Old Man Emu to be suitable for off road use and their legality for public road use should be certified by the relevant Registration Authority. An Off Road Use Only Disclaimer must be signed by the customer.

Modifications and replacement of other associated components will be required.

Lift increase is approximate and will depend on vehicle weights.

Warranty Implications

The fitter selling these shocks **must** inform the customer there is **no warranty** due to the severe nature of competition racing. The fitter must also note on the customer's receipt "racing application no warranty applies". This will prevent any future misunderstanding.

PRADO 150 SERIES 10/2017 ON LWB⁴ COIL SPRUNG MODELS ONLY

FRONT <i>Estimated Lift: 20mm</i>	V6 4.0L PETROL ENGINE			2.8L & 3.0L DIESEL ENGINE		
	PART NUMBER	QTY	UNIT PRICE \$	PART NUMBER	QTY	UNIT PRICE \$
SPRING: NO BAR	2883	[1] 1		2869	[1] 1	
STRUT - SPORT	90010	[2] 2		90010	[2] 2	
SPRING: BAR ONLY	2869	[1] 1		2884	[1] 1	
STRUT - SPORT	90010	[2] 2		90010	[2] 2	
SPRING: BAR AND WINCH	2884	[1] 1		2885	[1] 1	
STRUT - SPORT	90010	[2] 2		90010	[2] 2	
TRIM PACKER	OME95PF5	[1]		OME95PF5	[1]	
UPPER STRUT BUSHES	OME3133	[2]	2	OME3133	[2]	2
STRUT TOP HAT KIT	OMETH002	[5]		OMETH002	[5]	

FRONT <i>Estimated Lift: 40mm</i>	V6 4.0L PETROL ENGINE			2.8L & 3.0L DIESEL ENGINE		
	PART NUMBER	QTY	UNIT PRICE \$	PART NUMBER	QTY	UNIT PRICE \$
SPRING: NO BAR	2884	[1] 1		2885	[1] 1	
STRUT - SPORT	90010	[2] 2		90010	[2] 2	
SPRING: BAR ONLY	2885	[1] 1		2887	[1] 1	
STRUT - SPORT	90010	[2] 2		90010	[2] 2	
SPRING: BAR AND WINCH	2887	[1] 1		2888	[1] 1	
STRUT - SPORT	90010	[2] 2		90010	[2] 2	
TRIM PACKER	OME95PF5	[1]		OME95PF5	[1]	
UPPER STRUT BUSHES	OME3133	[2]	2	OME3133	[2]	2
STRUT TOP HAT KIT	OMETH002	[5]		OMETH002	[5]	
BP-51 SELECTION Estimated Lift: 20 - 40mm NON KDSS MODELS				KDSS MODELS		
BP-51 COIL OVER FRONT LH	BP5190002L		1	BP5190004L		1
BP-51 COIL OVER FRONT RH	BP5190002R			BP5190002R		
BP-51 FIT KIT FRONT	VM80010008			VM80010009		

REAR <i>Estimated Lift: 20mm</i>	LWB MODELS		
	PART NUMBER	QTY	UNIT PRICE \$
SPRING: MEDIUM LOAD	2895E	1	
NITROCHARGER SPORT	60080	[3] 2	
SPRING: CONSTANT 200 KGS	2895	1	
NITROCHARGER SPORT	*60081 / 60080	[3] 2	
SPRING: CONSTANT 400 KGS	2896	1	
NITROCHARGER SPORT	60081	[3] 2	
TRIM PACKER	OME150PR10		
STONE GUARD KIT	OME661	[3] 1	

REAR <i>Estimated Lift: 40mm</i>	LWB MODELS		
	PART NUMBER	QTY	UNIT PRICE \$
SPRING: MEDIUM LOAD	2889	1	
NITROCHARGER SPORT	60080	[3] 2	
SPRING: CONSTANT 200 KGS	2898	1	
NITROCHARGER SPORT	*60081 / 60080	[3] 2	
SPRING: CONSTANT 400 KGS	2899	1	
NITROCHARGER SPORT	60081	[3] 2	
TRIM PACKER	OME150PR10		
STONE GUARD KIT	OME661	[3] 1	
BP-51 SELECTION - ALL MODELS Estimated Lift: 20 - 40mm			
BP-51 SHOCK REAR	BP5160025	2	
BP-51 FIT KIT REAR	VM80010010	1	

REMARKS:

- 1** Vehicles with KDSS, must have 1 x OME95PF5 packer installed on the front right hand side to maintain correct trim.
- 2** No top mounting bushes supplied, use OME3133. OE bushes may be re-used if in good condition.
- 3** OME661 Lower Shock Mount Stone Guard is recommended fitment to rear shocks to protect against severe stone pepping encountered on loose road surfaces.
- 4** For Fitment to Models with Toyota's KDSS (Kinetic Dynamic Suspension System) fitted, please refer to OME's Fitting Hints & Tips (OME Bulletin 70 LC200 KDSS Fitting Hints).
- 5** Strut Top Hat Kit may be required if original equipment is worn.

PRADO 150 SERIES TO 09/2017 LWB⁴ COIL SPRUNG MODELS ONLY

FRONT <i>Estimated Lift: 30mm</i>	V6 4.0L PETROL ENGINE			2.8L & 3.0L DIESEL ENGINE		
	PART NUMBER	QTY	UNIT PRICE \$	PART NUMBER	QTY	UNIT PRICE \$
SPRING: NO BAR	2883 1 5	1		2883 1	1	
STRUT - SPORT	90010 2	2		90010 2	2	
SPRING: BAR ONLY	2883 1	1		2869 1	1	
STRUT - SPORT	90010 2	2		90010 2	2	
SPRING: BAR AND WINCH	2869 1	1		2884 1	1	
STRUT - SPORT	90010 2	2		90010 2	2	
TRIM PACKER	OME95PF5 1			OME95PF5 1		
UPPER STRUT BUSHES	OME3133 2	2		OME3133 2	2	
STRUT TOP HAT KIT	OMETH002 6	2		OMETH002 6	2	

FRONT <i>Estimated Lift: 50mm</i>	V6 4.0L PETROL ENGINE			2.8L & 3.0L DIESEL ENGINE		
	PART NUMBER	QTY	UNIT PRICE \$	PART NUMBER	QTY	UNIT PRICE \$
SPRING: NO BAR	2869 1	1		2884 1	1	
STRUT - SPORT	90010 2	2		90010 2	2	
SPRING: BAR ONLY	2884 1	1		2885 1	1	
STRUT - SPORT	90010 2	2		90010 2	2	
SPRING: BAR AND WINCH	2885 1	1		2887 1	1	
STRUT - SPORT	90010 2	2		90010 2	2	
TRIM PACKER	OME95PF5 1			OME95PF5 1		
UPPER STRUT BUSHES	OME3133 2	2		OME3133 2	2	
STRUT TOP HAT KIT	OMETH002 6	2		OMETH002 6	2	
BP-51 SELECTION Estimated Lift: 30 - 50mm NON KDSS MODELS				KDSS MODELS		
BP-51 COIL OVER FRONT LH	BP5190002L	1		BP5190004L	1	
BP-51 COIL OVER FRONT RH	BP5190002R			BP5190002R		
BP-51 FIT KIT FRONT	VM80010008			VM80010009		

REAR <i>Estimated Lift: 30mm</i>	LWB MODELS		
	PART NUMBER	QTY	UNIT PRICE \$
SPRING: MEDIUM LOAD	2895E	1	
NITROCHARGER SPORT	60080 3	2	
SPRING: CONSTANT 200 KGS	2895	1	
NITROCHARGER SPORT	*60081 / 60080 3	2	
SPRING: CONSTANT 400 KGS	2896	1	
NITROCHARGER SPORT	60081 3	2	
TRIM PACKER	OME150PR10		
STONE GUARD KIT	OME661 3	1	

REAR <i>Estimated Lift: 50mm</i>	LWB MODELS		
	PART NUMBER	QTY	UNIT PRICE \$
SPRING: MEDIUM LOAD	2889	1	
NITROCHARGER SPORT	60080 3	2	
SPRING: CONSTANT 200 KGS	2898	1	
NITROCHARGER SPORT	*60081 / 60080 3	2	
SPRING: CONSTANT 400 KGS	2899	1	
NITROCHARGER SPORT	60081 3	2	
TRIM PACKER	OME150PR10		
STONE GUARD KIT	OME661 3	1	
BP-51 SELECTION - ALL MODELS Estimated Lift: 30 - 50mm			
BP-51 SHOCK REAR	BP5160025	2	
BP-51 FIT KIT REAR	VM80010010	1	

REMARKS:

- 1 Vehicles with KDSS, must have 1 x OME95PF5 packer installed on the front right hand side to maintain correct trim.
- 2 No top mounting bushes supplied, use OME3133. OE bushes may be re-used if in good condition.
- 3 OME661 Lower Shock Mount Stone Guard is recommended fitment to rear shocks to protect against severe stone pepping encountered on loose road surfaces.
- 4 For Fitment to Models with Toyota's KDSS (Kinetic Dynamic Suspension System) fitted, please refer to OME's Fitting Hints & Tips (OME Bulletin 70 LC200 KDSS Fitting Hints).
- 5 When 2883 fitted to Petrol Model ride height increase will be approximately 40mm.
- 6 Strut Top Hat Kit may be required if original equipment is worn.

PRADO 150 SERIES SWB 2009 ON COIL SPRUNG MODELS ONLY

FRONT <i>Estimated Lift: 40mm</i>	V6 4.0L PETROL ENGINE			3.0L DIESEL ENGINE		
	PART NUMBER	QTY	UNIT PRICE \$	PART NUMBER	QTY	UNIT PRICE \$
SPRING: NO BAR	2883	1		2869	1	
STRUT - SPORT	90016 2	2		90016 2	2	
SPRING: BAR ONLY	2869	1		2884	1	
STRUT - SPORT	*90010 / 90016 2	2		*90010 / 90016 2	2	
SPRING: BAR AND WINCH	2884	1		2885	1	
STRUT - SPORT	90010 2	2		90010 2	2	
TRIM PACKER	OME95PF5 1			OME95PF5 1		
UPPER STRUT BUSHES	OME3133 2	2		OME3133 2	2	
STRUT TOP HAT KIT	OMETH002 4	2		OMETH002 4	2	

REAR <i>Estimated Lift: 40mm</i>	WAGON MODELS		
	PART NUMBER	QTY	UNIT PRICE \$
SPRING: MEDIUM LOAD	2895E	1	
NITROCHARGER SPORT	60086 3	2	
SPRING: CONSTANT 200 KGS	2895	1	
NITROCHARGER SPORT	*60080 / 60086 3	2	
SPRING: CONSTANT 400 KGS	2896	1	
NITROCHARGER SPORT	60080 3	2	
TRIM PACKER	OME150PR10		
STONE GUARD KIT	OME661 3	1	

REMARKS:

- 1** Vehicles with KDSS, **must** have 1 x OME95PF5 packer installed on the front right hand side to maintain correct trim.
- 2** No top mounting bushes supplied, use OME3133. OE bushes may be re-used if in good condition.
- 3** OME661 Lower Shock Mount Stone Guard is recommended fitment to rear shocks to protect against severe stone pepping encountered on loose road surfaces.
- 4** Strut Top Hat Kit may be required if original equipment is worn.

PRADO 120 SERIES 4/2003 TO 2009 LWB & SWB EXCEPT TEMS MODEL (ELECTRONICALLY MODULATED SUSPENSION)

FRONT <i>Estimated Lift: 25mm</i>	PETROL & DIESEL ENGINES		
	PART NUMBER	QTY	UNIT PRICE \$
SPRING: TO 50 KGS	2883 1	1	
STRUT - SPORT	*90000 / 90021 4	2	
STRUT	N140S		
SPRING: 51 TO 100 KGS	2884 1	1	
STRUT - SPORT	90000		
STRUT	*N201S / N140S 4 5	2	
SPRING: 101 TO 150 KGS	2885 1	1	
STRUT - SPORT	90000		
STRUT	N201S 4 5	2	
TRIM PACKER	OME95PF5		
UPPER STRUT BUSHES	OME3133 4	2	
STRUT TOP HAT KIT	OMETH002 6	2	
BP-51 SELECTION			
BP-51 COIL OVER PRADO FRONT LH	BP5190002L		
BP-51 COIL OVER PRADO FRONT RH	BP5190002R	1	
BP-51 FIT KIT PRADO 120 FRONT	VM80010029		

REMARKS:

- 1** To maintain front strut droop it is important front coils are selected as shown.
- 2** OME661 Lower Shock Mount Stone Guard is recommended fitment to rear shocks to protect against severe stone peppering encountered on loose road surfaces.
- 3** 2895E suits LWB Models without OE 2nd fuel tank. 2895 suits LWB Models with OE 2nd fuel tank.
- 4** No top mounting bushes supplied, use OME3133. OE bushes may be re-used if in good condition.
- 5** When remaining stock of N201S and N202 is exhausted no further product will be available.
- 6** Strut Top Hat Kit may be required if original equipment is worn.

REAR <i>Estimated Lift: 40mm</i>	LWB MODEL		
	PART NUMBER	QTY	UNIT PRICE \$
SPRING: MEDIUM LOAD	2895E 3	1	
	2895		
NITROCHARGER SPORT	*60004 / 60112 2	2	
NITROCHARGER	N141		
SPRING: 150 KGS - 400 KGS	2896	1	
NITROCHARGER SPORT	*60005 / 60004 2	2	
NITROCHARGER	N202 5		
SPRING: CONSTANT 400 KGS	2897	1	
NITROCHARGER SPORT	60005		
NITROCHARGER	N202 2 5	2	
STONE GUARD KIT	OME661 2	1	
BP-51 SELECTION			
BP-51 SHOCK PRADO REAR	BP5160025	2	
BP-51 FIT KIT PRADO REAR	VM80010010	1	

REAR <i>Estimated Lift: 40mm</i>	SWB MODEL		
	PART NUMBER	QTY	UNIT PRICE \$
SPRING: MEDIUM LOAD	2895E	1	
NITROCHARGER SPORT	*60004 / 60112 2	2	
NITROCHARGER	N141		
SPRING: 150KGS - 250KGS	2895	1	
NITROCHARGER SPORT	*60005 / 60004 2	2	
NITROCHARGER	N202 5		
SPRING: CONSTANT 400 KGS	2896	1	
NITROCHARGER SPORT	60005		
NITROCHARGER	N202 2 5	2	
STONE GUARD KIT	OME661 2	1	
BP-51 SELECTION			
BP-51 SHOCK PRADO REAR	BP5160025	2	
BP-51 FIT KIT PRADO REAR	VM80010010	1	

PRADO 90 SERIES TO 10/2002 LWB

FRONT <i>Estimated Lift: 40mm</i>	V6 PETROL ENGINE			DIESEL ENGINE		
	PART NUMBER	QTY	UNIT PRICE \$	PART NUMBER	QTY	UNIT PRICE \$
SPRING: TO 50 KGS	2880 1	1		2881 1	1	
STRUT - SPORT	90004	2		90004	2	
SPRING: 51 TO 110 KGS	2881 1	1		2882 1	1	
STRUT - SPORT	90004	2		90004	2	
TRIM PACKER	OME95PF5			OME95PF5		

REAR <i>Estimated Lift: 40mm</i>	ALL MODELS			REMARKS:
	PART NUMBER	QTY	UNIT PRICE \$	
SPRING: MEDIUM LOAD	2890	1		<p>1 To maintain front strut droop it is important front coils are selected as shown.</p> <p>2 OME661 Lower Shock Mount Stone Guard is recommended fitment to rear shocks to protect against severe stone pepping encountered on loose road surfaces.</p>
NITROCHARGER SPORT	60028	2		
NITROCHARGER	N86	2		
SPRING: CONSTANT 150 KGS	2891	1		
NITROCHARGER SPORT	*60027 / 60028	2		
NITROCHARGER	N86	2		
SPRING: CONSTANT 300 KGS	2892	1		
NITROCHARGER SPORT	60027	2		
NITROCHARGER	N86	2		
TRIM PACKER	OME80PF05			
	OME80PF10			
STONE GUARD KIT	OME661	2	1	

TUNDRA 2007 ON

FRONT				
<i>Estimated Lift: 60mm</i>		PART NUMBER	QTY	UNIT PRICE \$
SPRING: NO BAR		2612	1	
STRUT SPORT		90018	2	
STRUT		N192S	1	
SPRING: BAR ONLY		2614	1	
STRUT SPORT		90018	2	
STRUT		N192S	1	
SPRING: BAR & WINCH		2613	1	
STRUT SPORT		90018	2	
STRUT		N192S	1	
BP-51 SELECTION				
BP-51 COIL OVER TUNDRA FRONT LH		BP5190010L	1	
BP-51 COIL OVER TUNDRA FRONT RH		BP5190010R		
BP-51 FIT KIT TUNDRA FRONT		VM80010034		
REAR				
<i>Estimated Lift: 60mm</i>		PART NUMBER	QTY	UNIT PRICE \$
SPRING: MEDIUM LOAD		CS055R	2	
NITROCHARGER SPORT		60100	2	
NITROCHARGER		N193	1	
BP-51 SELECTION				
BP-51 SHOCK TUNDRA REAR LH		BP5160020L	1	
BP-51 SHOCK TUNDRA REAR RH		BP5160020R		
BP-51 FIT KIT TUNDRA REAR		VM80010035		
XL LEAF		D28XL	2	
SPRING BUSH KIT		OMESB106		
U BOLTS		OMEU53B	4	
FITTING KIT		FK32	1	
GREASABLE SHACKLE KIT		OMEGS22	1	

REMARKS:

- 1** No top mounting bushes supplied, re-use OE bushes.
- 2** Models with rear sway bar will require end link modifications to retain sway bar in operation.
- 3** FK32 Brake Line and ABS Wire Bracket Relocation Kit is a **mandatory** fitment.
- 4** Please note CS055R is supplied with bushes installed.

FRONT

FRONT				
<i>Estimated Lift: 50mm</i>		PART NUMBER	QTY	UNIT PRICE \$
SPRING: NO ACCESSORIES		2883	1	
NITROCHARGER SPORT		*90010 / 90016 1	2	
SPRING: TO 60 KGS		2884	1	
NITROCHARGER SPORT		90010 1	2	
SPRING: 60 TO 120 KGS		2885	1	
NITROCHARGER SPORT		90010 1	2	
BP-51 SELECTION				
BP-51 COIL OVER FRONT LH		BP5190002L	1	
BP-51 COIL OVER FRONT RH		BP5190002R		
BP-51 FIT KIT FRONT		VM80010008		
TRIM PACKER		OME95PF5		
UPPER STRUT BUSHES		OME3133 1	2	
STRUT TOP HAT KIT		OMETH002 3	2	

REMARKS:

- 1** No top mounting bushes supplied, use OME3133. OE bushes may be re-used if in good condition.
- 2** OME661 lower shock mount guard is recommended fitment to rear shocks to protect against severe stone pepping encountered on loose road surfaces.
- 3** Strut Top Hat Kit may be required if original equipment is worn.

REAR		ALL MODELS		
<i>Estimated Lift: 50mm</i>		PART NUMBER	QTY	UNIT PRICE \$
SPRING: LIGHT LOAD		2895E	1	
NITROCHARGER SPORT		*60080 / 60086 2	2	
SPRING: MEDIUM LOAD		2895	1	
NITROCHARGER SPORT		*60081 / 60080 2	2	
SPRING: CONSTANT 200 KGS		2896	1	
NITROCHARGER SPORT		60081 2	2	
STONE GUARD KIT		OME661 2	1	
BP-51 SELECTION				
BP-51 SHOCK REAR		BP5160025	2	
BP-51 FIT KIT REAR		VM80010010	1	

FJ CRUISER 2006 TO 2010

FRONT <i>Estimated Lift: 50mm</i>	ALL MODELS		
	PART NUMBER	QTY	UNIT PRICE \$
SPRING: NO ACCESSORIES	2883	1	
STRUT - SPORT	*90000 / 90021	2	
STRUT	N140S		
SPRING: TO 60 KGS	2884	1	
STRUT - SPORT	90000	2	
STRUT	N140S		
SPRING: 60 TO 120 KGS	2885	1	
STRUT - SPORT	90000	2	
STRUT	N140S		
TRIM PACKER	OME95PF5		
UPPER STRUT BUSHES	OME3133	1	
STRUT TOP HAT KIT	OMETH002	3	

REMARKS:

- 1** No top mounting bushes supplied, use OME3133. OE bushes may be re-used if in good condition.
- 2** OME661 lower shock mount guard is recommended fitment to rear shocks to protect against severe stone pepping encountered on loose road surfaces.
- 3** Strut Top Hat Kit may be required if original equipment is worn.

REAR <i>Estimated Lift: 50mm</i>	ALL MODELS		
	PART NUMBER	QTY	UNIT PRICE \$
SPRING: LIGHT LOAD	2895E	1	
NITROCHARGER SPORT	*60004 / 60112	2	
NITROCHARGER	N141		
SPRING: MEDIUM LOAD	2895	1	
NITROCHARGER SPORT	*60004 / 60112	2	
NITROCHARGER	N141		
SPRING: CONSTANT 200 KGS	2896	1	
NITROCHARGER SPORT	60081	2	
STONE GUARD KIT	OME661	2	

FORTUNER 2015 ON

FRONT <i>Estimated Lift: 35mm</i>	DIESEL ENGINE		
	PART NUMBER	QTY	UNIT PRICE \$
SPRING: NO BAR	2869	1	
STRUT - SPORT	90028	2	
SPRING: BAR ONLY	2884	1	
STRUT - SPORT	90028	2	
SPRING: BAR & WINCH	2885	1	
STRUT - SPORT	90029	2	
SPRING: BAR, WINCH & ACCESSORIES	2887	1	
STRUT - SPORT	90029	2	
TRIM PACKER	OME95PF5		
UPPER STRUT BUSHES	OME3133	2	
STRUT TOP HAT KIT	OMETH002	3	

REMARKS:

- 1** To maintain coil clearance from the sway Bar, the coil seat must be installed with the helix facing away from the sway bar.
- 2** No top mounting bushes supplied, use OME3133. OE bushes may be re-used if in good condition.
- 3** Strut Top Hat Kit may be required if original equipment is worn.
- 4** FK29 Rear Driveshaft Spacer is a **mandatory** fitment.

REAR <i>Estimated Lift: 25mm</i>	ALL MODELS		
	PART NUMBER	QTY	UNIT PRICE \$
SPRING: MEDIUM LOAD	2802	1	
NITROCHARGER SPORT	60141	2	
SPRING: CONSTANT 200 KGS	2803	1	
NITROCHARGER SPORT	60142	2	
REAR DRIVESHAFT SPACER	FK29	1	

FORTUNER 2004 TO 2015

FRONT <i>Estimated Lift: 40mm</i>			
	PART NUMBER	QTY	UNIT PRICE \$
SPRING: TO 75 KGS	2883	1	
STRUT - SPORT	*90002 / 90011	2	
STRUT	*N167S / N166S 1		
SPRING: 76 TO 120 KGS	2884	1	
STRUT - SPORT	*90002 / 90011	2	
STRUT	N167S 1		
TRIM PACKER	OME95PF5		
UPPER STRUT BUSHES	OME3133 1		
STRUT TOP HAT KIT	OMETH002 2		

REAR <i>Estimated Lift: 40mm</i>	ALL MODELS		
	PART NUMBER	QTY	UNIT PRICE \$
SPRING: MEDIUM LOAD	2802	1	
NITROCHARGER SPORT	60078	2	
NITROCHARGER	N191		
SPRING: CONSTANT 200 KGS	2803	1	
NITROCHARGER SPORT	60077	2	
NITROCHARGER	N191		

REMARKS:

- 1 No top mounting bushes supplied, use OME3133. OE bushes may be re-used if in good condition.
- 2 Strut Top Hat Kit may be required if original equipment is worn.

LANDCRUISER 70 SERIES DUAL CAB¹³

FRONT <i>Estimated Lift: 40mm</i>	PETROL & DIESEL 6 CYLINDER ENGINES			V8 DIESEL ENGINE		
	PART NUMBER	QTY	UNIT PRICE \$	PART NUMBER	QTY	UNIT PRICE \$
SPRING: TO 50 KGS	2856 [6][9]	1		2859 [6][9]	1	
NITROCHARGER SPORT	60008	2		60008	2	
NITROCHARGER	N181 [10]			N181 [10]		
SPRING: 51 TO 120 KGS	2859 [6][9]	1		2853 [6][9]	1	
NITROCHARGER SPORT	60008	2		60008	2	
NITROCHARGER	N181 [10]			N181 [10]		
STEERING DAMPER	OMESD24 [3]	1		OMESD47 [3]	1	
CASTER KIT	OMECA77B [1]			OMECA77B [1]		
SWAY BAR SPACER KIT	FK19 [4]			FK19 [4]		
TRIM PACKER	OME79PF10			OME79PF10		
UPGRADED FRONT SWAY BAR	NOT APPLICABLE	-		OMESTAB3	1	
ABS WIRE BRACKET KIT	FK65 [9]	1		FK65 [9]		
BP-51 SELECTION						
BP-51 SHOCK FRONT	BP5160009	2				
BP-51 FIT KIT FRONT	VM80010006	1				
REAR						
<i>Estimated Lift: All Models: 45mm</i>						
70 SERIES DUAL CAB						
	PART NUMBER	QTY	UNIT PRICE \$			
SPRING: MEDIUM LOAD	EL079R [5][8]	2				
NITROCHARGER SPORT	60010					
SPRING: CONSTANT 300 KGS	EL080R [5][8]	2				
NITROCHARGER SPORT	60011					
SPRING: CONSTANT 500 KGS	EL081R [5][8]	2				
NITROCHARGER SPORT	60011					
SPRING: CONSTANT 700 KGS	EL082R [5][7][8][12]	2				
NITROCHARGER SPORT	60109					
BP-51 SELECTION						
BP-51 SHOCK REAR	BP5160028	2				
BP-51 SHOCK REAR LONG 682 (Suits EL082R Only)	BP5160029	1				
BP-51 FIT KIT REAR	VM80010007	1				
SPRING BUSH KIT	OMESB101 [2]	2				
	OMESB85 [2]					
GREASABLE SHACKLE KIT	OMEGB10	1				
GREASABLE SHACKLE FIXED END PIN KIT	OMEGP7					
U BOLTS	OMEU59B [12]	4				
	OMEU59C [12]					
SWAY BAR	OMESTAB9 [7]	1				
SWAY BAR FIT KIT	FK77 [7]					
	FK76 [7]					
BRAKE PROPORTIONING KIT	FK51 [8]					
	FK58 [8]					
REAR BRAKE LINE DROP 2014 TO 08/16	FK82 [11]					
EXTRA LEAF	EL14XL	2				

- 4** Should the front drive shaft contact the sway bar when the suspension is at full droop, use FK19 Spacer Kit to pack the sway bar down.
- 5** Include tray weight in constant load calculation.
- 6** For heavily loaded applications it may be necessary to step down one spring selection in the front to maintain correct rake.
- 7** OMESTAB9 Sway Bar is highly recommended fitment when 700kg Constant Spring is used. Sway Bar can also be fitted to lighter rated springs to improve road handling. FK76 suits Models with OE axle sway bar mount. FK77 suits Models without OE sway bar provision.
- 8** FK51 and FK58 suit vehicles prior to August 2016 production. FK51 is Brake Proportioning Valve Kit for medium load and 300kg spring. FK58 is for 500kg and 700kg spring. Due to variance in tray clearance on 70 Series Dual Cab please check vehicle before selecting Fit Kit. Not required for BP-51 fitment.
- 9** For vehicles fitted with ABS brakes, an ABS Wire Bracket Kit must be fitted. FK65 suits vehicles prior to August 2016 production. For vehicles post August 2016 production refer to PIB No. 343.

REMARKS:

- 1** OMECA77B Caster Kit will increase caster angle by 2°. Check manufacturer's specifications to determine if OMECA77B kit is required.
- 2** OMESB101: Use on original shackles and pins. OMESB85: Use for all Models when installing OME greasable shackles and pins
- 3** OMESD47 suits 2007 On Models (open length 750mm).
- 10** When remaining stock of N181 is exhausted no further product will be available.
- 11** Required to be fitted to vehicles from 10/14 to 08/16.
- 12** Use OMEU59C if fitting Extra Leaf to EL082R.
- 13** Excludes 1GR-FE Models.

LANDCRUISER 76 SERIES WAGON

FRONT <i>Estimated Lift: 50mm</i>	V8 DIESEL ENGINE		
	PART NUMBER	QTY	UNIT PRICE \$
SPRING: TO 60 KGS	2856 [8][9]	1	
NITROCHARGER SPORT	60008	2	
SPRING: 61 TO 120 KGS	2859 [8][9]	1	
NITROCHARGER SPORT	60008	2	
NITROCHARGER	N181 [11]		
STEERING DAMPER	OMESD47		
CASTER KIT	OMECA77B [1]	1	
SWAY BAR SPACER KIT	FK19 [4]		
UPGRADED FRONT SWAY BAR	OMESTAB3		
ABS WIRE BRACKET KIT	FK65 [8]		
BP-51 SELECTION			
SHOCK LC 76 FRONT	BP5160009	2	
BP KIT LC 76 FRONT	VM80010006	1	

REAR <i>Estimated Lift: 50mm</i>	ALL MODELS		
	PART NUMBER	QTY	UNIT PRICE \$
SPRING: MEDIUM	CS057R	2	
NITROCHARGER SPORT	60010 [5]		
SPRING: CONSTANT 400 KGS	CS058R [7]	2	
NITROCHARGER SPORT	*60111 / 60011 [5]		
SPRING: CONSTANT 800 KGS	CS070R [6][7][10]	2	
NITROCHARGER SPORT	60111 [5]		
SPRING BUSH KIT	OMESB86 [2]	2	
	OMESB85		
GREASABLE SHACKLE KIT	OMEGS19 [3]	1	
GREASABLE SHACKLE FIXED END PIN KIT	OMEGP7		
ANTI-INVERSION KIT	FK38 [3]		
U BOLTS	OMEU59B [10]	4	
	OMEU59D		
CENTRE BOLT	UCB17	2	
STONE GUARD KIT	OME661 [5]	1	
EXTRA LEAF	D35XL	2	
SWAY BAR	OMESTAB9 [6]	1	
SWAY BAR FIT KIT	FK77 [6]		
	FK76		
BRAKE PROPORTIONING BRACKET	FK51 [7]		
	FK58		
REAR BRAKE LINE DROP 2014 TO 08/16	FK82 [12]		
BP-51 SELECTION			
SHOCK LC 76 REAR	BP5160028	2	
BP KIT LC 76 REAR	VM80010007	1	

REMARKS:

- 1** OMECA77B Caster Kit will increase caster angle by 2°. Check manufacturer's specifications to determine if required.
- 2** Be sure to select OME Bush Kits
OMESB85: Use for all Models when installing OME greasable shackles and pins.
OMESB86: Use when original shackles and pins are used.
- 3** To prevent springs from inverting it is **mandatory** that either OMEGS19 Greasable Shackle Kit or FK38 Anti-Inversion Kit be installed.
- 4** Should the front drive shaft contact the sway bar when the suspension is at full droop, use FK19 Spacer Kit to pack the sway bar down.
- 5** OME661 Lower Shock Mount Stone Guard is recommended fitment to rear shocks to protect against severe stone pepping encountered on loose road surfaces.
- 6** FK76 suits Models with OE sway bar mount. FK77 suits Models without sway bar provision. OMESTAB9 Sway Bar is highly recommended when 800kg constant spring is used.
- 7** FK51 and FK58 suit vehicles prior to August 2016 production. FK51 is Brake Proportioning Kit for 400kg spring. FK58 is for the 800kg spring. Not required for BP-51 fitment.
- 8** For vehicles fitted with ABS brakes, an ABS Wire Bracket Kit must be fitted. FK65 suits vehicles prior to August 2016 production. For vehicles post August 2016 production refer to PIB No. 343.
- 9** For heavily loaded applications it may be necessary to step down one spring selection in the front to maintain correct rake.
- 10** Use OMEU59B when fitting CS070R springs.
- 11** When remaining stock of N181 is exhausted no further product will be available.
- 12** Required to be fitted to vehicles from 10/14 To 08/16.

LANDCRUISER 78 SERIES¹²

FRONT <i>Estimated Lift: 40mm</i>	PETROL & DIESEL 6 CYLINDER ENGINES			V8 DIESEL ENGINE		
	PART NUMBER	QTY	UNIT PRICE \$	PART NUMBER	QTY	UNIT PRICE \$
SPRING: TO 50 KGS	2856 [6][9]	1		2859 [6][9]	1	
NITROCHARGER SPORT	60008	2		60008	2	
NITROCHARGER	N181 [10]			N181 [10]		
SPRING: 51 TO 120 KGS	2859 [6][9]	1		2853 [6][9]	1	
NITROCHARGER SPORT	60008	2		60008	2	
NITROCHARGER	N181 [10]			N181 [10]		
STEERING DAMPER	OMESD24 [5]	1		OMESD47	1	
CASTER KIT	OMECA77B [1]			OMECA77B [1]		
SWAY BAR SPACER KIT	FK19 [4]			FK19 [4]		
TRIM PACKER	OME79PF10			OME79PF10		
UPGRADED FRONT SWAY BAR	NOT APPLICABLE	-		OMESTAB3	1	
ABS WIRE BRACKET KIT	FK65 [9]	1		FK65 [9]		
BP-51 SELECTION - ALL MODELS						
SHOCK LC 78 FRONT	BP5160009	2		3 FK34 Sway Bar Extension Bracket Kit must be installed to prevent damage to sway bar mounts, due to increased suspension travel. FK34 not needed if fitting OMESTAB9.		
BP KIT LC 78 FRONT	VM80010006	1				
REAR						
<i>Estimated Lift:</i>						
<i>All Models: 45mm</i>						
78 SERIES TROOP CARRIER						
	PART NUMBER	QTY	UNIT PRICE \$	4 Should the front drive shaft contact the sway bar when the suspension is at full droop, use FK19 Spacer Kit to pack the sway bar down.		
SPRING: CONSTANT 200 KGS	EL079R [3][8]	2		5 OMESD24 suits pre 2007 Models (open length 651mm). OMESD47 suits 2007 On Models (open length 750mm).		
NITROCHARGER SPORT	60010					
SPRING: CONSTANT 400 KGS	EL080R [3][8]	2		6 For heavily loaded applications it may be necessary to step down one spring selection in the front to maintain correct rake.		
NITROCHARGER SPORT	60011					
SPRING: CONSTANT 600 KGS	EL081R [3][8]	2		7 OMESTAB9 Sway Bar is highly recommended fitment when 800kg Constant Spring is used. Sway Bar can also be fitted to lighter rated springs to improve road handling. FK76 suits Models with OE axle sway bar mount. FK77 suits Models without OE sway bar provision.		
NITROCHARGER SPORT	60011					
SPRING: CONSTANT 800 KGS	EL082R [7][8][11]	2		8 FK51 and FK58 suit vehicles prior to August 2016 production. FK51 is Brake Proportioning Valve Kit for 200kg and 400kg spring. FK58 is for 600kg and 800kg spring. Not required for BP-51 fitment.		
NITROCHARGER SPORT	60109					
SPRING BUSH KIT	OMESB86 [2]	2		9 For vehicles fitted with ABS brakes, an ABS Wire Bracket Kit must be fitted. FK65 suits vehicles prior to August 2016 production. For vehicles post August 2016 production refer to PIB No. 343.		
	OMESB85					
GREASABLE SHACKLE KIT	OMEGB19	1		10 When remaining stock of N181 is exhausted no further product will be available.		
GREASABLE SHACKLE FIXED END PIN KIT	OMEGP7					
U BOLTS	OMEU59B [11]	4		11 Use OMEU59C if fitting Extra Leaf to EL082R.		
	OMEU59C					
SWAY BAR	OMESTAB9 [3][7]	1		12 Excludes 1GR-FE Models.		
SWAY BAR FIT KIT	FK77 [7]					
	FK76					
SWAY BAR EXTENSION BRACKET KIT	FK34 [3]					
BRAKE PROPORTIONING KIT	FK51 [8]					
	FK58					
EXTRA LEAF	EL14XL	2				
REAR BRAKE LINE DROP REQUIRED ON MODELS 10/14 TO 08/16	FK82	1				
BP-51 SELECTION						
SHOCK LC 78 REAR	BP5160028	2				
SHOCK LC 78 REAR LONG 682 (Suits EL082R Only)	BP5160029					
BP KIT LC 78 REAR	VM80010007	1				

REMARKS:

- 1** OMECA77B Caster Kit will increase caster angle by 2°. Check manufacturer's specifications to determine if OMECA77B kit is required.
- 2** OMESB85: Use for all Models when installing OME greasable shackles and pins. OMESB86: Use for Troop Carrier Models when original shackles and pins are used.

- 3** FK34 Sway Bar Extension Bracket Kit must be installed to prevent damage to sway bar mounts, due to increased suspension travel. FK34 not needed if fitting OMESTAB9.
- 4** Should the front drive shaft contact the sway bar when the suspension is at full droop, use FK19 Spacer Kit to pack the sway bar down.
- 5** OMESD24 suits pre 2007 Models (open length 651mm). OMESD47 suits 2007 On Models (open length 750mm).
- 6** For heavily loaded applications it may be necessary to step down one spring selection in the front to maintain correct rake.
- 7** OMESTAB9 Sway Bar is highly recommended fitment when 800kg Constant Spring is used. Sway Bar can also be fitted to lighter rated springs to improve road handling. FK76 suits Models with OE axle sway bar mount. FK77 suits Models without OE sway bar provision.
- 8** FK51 and FK58 suit vehicles prior to August 2016 production. FK51 is Brake Proportioning Valve Kit for 200kg and 400kg spring. FK58 is for 600kg and 800kg spring. Not required for BP-51 fitment.
- 9** For vehicles fitted with ABS brakes, an ABS Wire Bracket Kit must be fitted. FK65 suits vehicles prior to August 2016 production. For vehicles post August 2016 production refer to PIB No. 343.
- 10** When remaining stock of N181 is exhausted no further product will be available.
- 11** Use OMEU59C if fitting Extra Leaf to EL082R.
- 12** Excludes 1GR-FE Models.

LANDCRUISER 79 SERIES SINGLE CAB (Excludes 1GR-FE Models)

FRONT <i>Estimated Lift: 40mm</i>	PETROL & DIESEL 6 CYLINDER ENGINES			V8 DIESEL ENGINE		
	PART NUMBER	QTY	UNIT PRICE \$	PART NUMBER	QTY	UNIT PRICE \$
SPRING: TO 50 KGS	2856 [6][9]	1		2859 [6][9]	1	
NITROCHARGER SPORT	60008	2		60008	2	
NITROCHARGER	N181 [11]	2		N181 [11]	2	
SPRING: 51 TO 120 KGS	2859 [6][9]	1		2853 [6][9]	1	
NITROCHARGER SPORT	60008	2		60008	2	
NITROCHARGER	N181 [11]	2		N181 [11]	2	
STEERING DAMPER	OMESD24 [3]	1		OMESD47	1	
CASTER KIT	OMECA77B [1]	1		OMECA77B [1]	1	
SWAY BAR SPACER KIT	FK19 [4]	1		FK19 [4]	1	
TRIM PACKER	OME79PF10	1		OME79PF10	1	
UPGRADED FRONT SWAY BAR	NOT APPLICABLE	-		OMESTAB3	1	
ABS WIRE BRACKET KIT	FK65 [9]	1		FK65 [9]	1	
BP-51 SELECTION - ALL MODELS						
SHOCK LC 79 FRONT	BP5160009	2				
BP KIT LC 79 FRONT	VM80010006	1				
REAR <i>Estimated Lift: All Models: 45mm</i>						
79 SERIES SINGLE CAB						
	PART NUMBER	QTY	UNIT PRICE \$			
SPRING: CONSTANT 200 KGS	EL079R [5][8]	2				
NITROCHARGER SPORT	60010	2				
SPRING: CONSTANT 400 KGS	EL080R [5][8]	2				
NITROCHARGER SPORT	60011	2				
SPRING: CONSTANT 600 KGS	EL081R [5][8]	2				
NITROCHARGER SPORT	60011	2				
SPRING: CONSTANT 800 KGS	EL082R [5][7][8][12]	2				
NITROCHARGER SPORT	60109	2				
SPRING BUSH KIT	OMESB101	2				
	OMESB84 [2]	2				
	OMESB85 [2]	2				
GREASABLE SHACKLE KIT	OMEGB10	1				
GREASABLE SHACKLE FIXED END PIN KIT	OMEGP7	1				
U BOLTS	OMEU59B [12]	4				
	OMEU59C	4				
SWAY BAR	OMESTAB9 [7]	1				
SWAY BAR FIT KIT	FK77 [7]	1				
	FK76 [7]	1				
	FK51 [8]	1				
BRAKE PROPORTIONING KIT	FK58 [8]	1				
REAR BRAKE LINE DROP 2014 TO 08/16	FK82 [10]	1				
EXTRA LEAF	EL14XL	2				
BP-51 SELECTION						
SHOCK LC 79 REAR	BP5160028	2				
SHOCK LC 79 REAR LONG 682 (Suits EL082R Only)	BP5160029	2				
BP KIT LC 79 REAR	VM80010007	1				

3 OMESD24 suits pre 2007 Models (open length 651mm). OMESD47 suits 2007On Models (open length 750mm).

4 Should the front drive shaft contact the sway bar when the suspension is at full droop, use FK19 Spacer Kit to pack the sway bar down.

5 Include tray weight in constant load calculation.

6 For heavily loaded applications it may be necessary to step down one spring selection in the front to maintain correct rake.

7 OMESTAB9 Sway Bar is highly recommended fitment when 800kg Constant Spring is used. Sway Bar can also be fitted to lighter rated springs to improve road handling. FK76 suits Models with OE axle sway bar mount. FK77 suits Models without OE sway bar provision.

8 FK51 and FK58 suit vehicles prior to August 2016 production. FK51 is Brake Proportioning Valve Kit for 200kg and 400kg spring. FK58 is for 600kg and 800kg spring. Due to variance in tray clearance on 79 Series please check vehicle before selecting Fit Kit. Not required for BP-51 fitment.

9 For vehicles fitted with ABS brakes, an ABS Wire Bracket Kit must be fitted. FK65 suits vehicles prior to August 2016 production. For vehicles post August 2016 production refer to PIB No. 343.

10 Required to be fitted to vehicles from 10/14 To 08/16.

11 When remaining stock of N181 is exhausted no further product will be available.

12 Use OMEU59C if fitting Extra Leaf to EL082R.

REMARKS:

1 OMECA77B Caster Kit will increase caster angle by 2°. Check manufacturer's specifications to determine if OMECA77B kit is required.

2 OMESB101: Use on original shackles and pins for 79 Series Models from 07/2009 On. OMESB84: Use on original shackles and pins for 79 Series Models To 06/2009. OMESB85: Use for all Models when installing OME greasable shackles and pins.

LANDCRUISER 75 SERIES⁷

FRONT <i>Estimated Lift: 50mm</i>	PETROL ENGINE			DIESEL ENGINE		
	PART NUMBER	QTY	UNIT PRICE \$	PART NUMBER	QTY	UNIT PRICE \$
SPRING: TO 50 KGS	CS006F 1 2	2		CS006F 2	2	
NITROCHARGER SPORT	60009			60009		
NITROCHARGER	N92 6			N92 6		
SPRING: 51 TO 110 KGS	CS006F 2	2		CS007F 2	2	
NITROCHARGER SPORT	60063			60063		
U BOLTS	OMEU51	4		OMEU51	4	
SPRING BUSH KIT	OMESB1	2		OMESB1	2	
GREASABLE SHACKLE KIT	OMEGS2	1		OMEGS2	1	
GREASABLE SHACKLE FIXED END PIN KIT	OMEGP1			OMEGP1		
STEERING DAMPER	OMESD24			OMESD24		
ANTI INVERSION KIT	FK08 2			FK08 2		
EXTRA LEAF	D16XL 5		2			D16XL 5
CENTRE BOLT	UCB5			UCB5		

REAR <i>Estimated Lift: 50mm</i>	ALL MODELS		
	PART NUMBER	QTY	UNIT PRICE \$
SPRING: MEDIUM LOAD	CS006R 2 4	2	
NITROCHARGER SPORT	60010		
SPRING: CONSTANT 400 KGS	CS007R 2 4	2	
NITROCHARGER SPORT	60011		
SPRING: CONSTANT 600 KGS	CS008R 2 4	2	
NITROCHARGER SPORT	60011		
SPRING BUSH KIT	OMESB16	2	
U BOLTS	OMEU59B	4	
GREASABLE SHACKLE KIT	OMEGS1	1	
GREASABLE SHACKLE FIXED END PIN KITS	OMEGP2 3		
	OMEGP4		
ANTI INVERSION KIT	FK08 2		
EXTRA LEAF	D25XL	2	
CENTRE BOLT	UCB4		

REMARKS:

- 1** Vehicles with no front accessory weight will require the removal of the 4th leaf from the top of the spring stack. This is to maintain good shackle angle by not allowing the bump stop measurement to exceed 100mm.
- 2** Shackles: FK08 Anti Inversion Kit is mandatory fitment front and rear if greasable shackles are not fitted.

Note: Spring Caster Wedge OMECW2 (2° Caster Wedges) may be required to restore positive caster angle. Front end alignment check will indicate required adjustment.
- 3** There can be 2 spigot sizes in the rear fixed end pins on 75 Series LandCruisers.
Check for correct size before ordering greasable pins. Part numbers are:
50mm spigot = OMEGP2.
51mm spigot = OMEGP4.
- 4** Include tray weight in constant load calculation.
- 5** D16XL is suitable for CS006F.
- 6** When remaining stock of N92 is exhausted no further product will be available.
- 7** Excludes 1GR-FE Models.

LANDCRUISER HZJ71 & HZJ74 SWB & MWB MODELS TO 2007

FRONT <i>Estimated Lift: 50mm</i>	DIESEL 4.2 ENGINES		
	PART NUMBER	QTY	UNIT PRICE \$
SPRING: TO 50 KGS	2856	1	
NITROCHARGER SPORT	60008	2	
SPRING: 51 TO 110 KGS	2859	1	
NITROCHARGER SPORT	60008	2	
STEERING DAMPER	OMESD24	1	
CASTER KIT	OMECA77B ¹		

REMARKS:

- 1** OMECA77B caster kit will increase caster angle by 3°. Check manufacturer's specifications to determine if OMECA77B kit is required.
- 2** If rear bump stop measurements exceed 150mm remove 3rd leaf.
- 3** OME greasable shackles OMEGS10 & greasable shackle fixed end pin kit OMEGP7 are **mandatory** fitment. OE shackles cannot be used.
- 4** D2XL extra leaf and UCB2 centre bolt is suitable for CS004RB spring.

REAR <i>Estimated Lift: 60mm</i>	ALL MODELS		
	PART NUMBER	QTY	UNIT PRICE \$
SPRING: MEDIUM LOAD	CS017RB ^{2 3}	2	
NITROCHARGER SPORT	60044		
SPRING: CONSTANT 250 KGS	CS004RB ^{2 3 4}	2	
NITROCHARGER SPORT	60044		
SPRING BUSH KIT	OMESB93	2	
U BOLTS	OMEU59A	4	
GREASABLE SHACKLE KIT	OMEGS10 ³	1	
GREASABLE SHACKLE FIXED END PIN KIT	OMEGP7		
EXTRA LEAF	D2XL ⁴	2	
CENTRE BOLT	UCB2		

LANDCRUISER II WAGON LWB

FRONT <i>Estimated Lift: 30mm</i>			
	PART NUMBER	QTY	UNIT PRICE \$
SPRING: TO 50 KGS	2872	1	
NITROCHARGER SPORT	60089	2	
SPRING: 51 TO 110 KGS	2874	1	
NITROCHARGER SPORT	60089	2	

REAR <i>Estimated Lift: 40mm</i>	ALL MODELS		
	PART NUMBER	QTY	UNIT PRICE \$
SPRING: MEDIUM LOAD	2873	1	
NITROCHARGER SPORT	60090	2	
SPRING: CONSTANT 100 KGS	2875	1	
NITROCHARGER SPORT	60090	2	

BUNDERA RJ70 11/1984 TO 1990

FRONT <i>Estimated Lift: 40mm</i>	PETROL & DIESEL ENGINES		
	PART NUMBER	QTY	UNIT PRICE \$
SPRING: TO 50 KGS	2870	1	
NITROCHARGER SPORT	60094	2	
SPRING: 51 TO 110 KGS	2876	1	
NITROCHARGER SPORT	60094	2	

REAR <i>Estimated Lift: 50mm</i>	ALL MODELS		
	PART NUMBER	QTY	UNIT PRICE \$
SPRING: MEDIUM LOAD	2871	1	
NITROCHARGER SPORT	60095		
	60096		

REMARKS:

- 1** 60095 fits left hand side.
60096 fits right hand side.

LANDCRUISER 70, 73, 74 SERIES SWB & MWB

FRONT <i>Estimated Lift: 50mm</i>	PETROL & DIESEL ENGINES		
	PART NUMBER	QTY	UNIT PRICE \$
SPRING: TO 50 KGS	CS006F 1 3	2	
NITROCHARGER SPORT	60009		
NITROCHARGER	N92 5		
SPRING: 51 TO 110 KGS	CS006F	2	
NITROCHARGER SPORT	60009		
SPRING BUSH KIT	OMESB1	2	
U BOLTS	OMEU51	4	
GREASABLE SHACKLE KIT	OMEGS2	1	
GREASABLE SHACKLE FIXED END PIN KIT	OMEGP1		
STEERING DAMPER	OMESD24		
ANTI INVERSION KIT	FK08 3		

REAR <i>Estimated Lift: 50mm</i>	ALL MODELS		
	PART NUMBER	QTY	UNIT PRICE \$
SPRING: MEDIUM LOAD	CS017RA / B 3	1 + 1	
NITROCHARGER SPORT	60062	2	
SPRING: CONSTANT 200 KGS	CS004RA / B 2 3 6	1 + 1	
NITROCHARGER SPORT	60062	2	
SPRING BUSH KIT	OMESB1	2	
U BOLTS	OMEU59A	4	
GREASABLE SHACKLE KIT	OMEGS2	1	
GREASABLE SHACKLE FIXED END PIN KITS	OMEGP2 4		
	OMEGP4 4		
ANTI INVERSION KIT	FK08 3		
EXTRA LEAF	D2XL 6	2	
CENTRE BOLT	UCB2		

REMARKS:

- 1** Vehicles with no front accessory weight will require the removal of the 4th leaf from the top of the spring stack. This is to maintain good shackle angle by not allowing the bump stop measurement to exceed 100mm.
- 2** If bump stop measurement exceeds 150 - 160mm remove 3rd leaf from top of spring stack to prevent shock absorber from topping out.
- 3** Shackles: FK08 Anti Inversion Kit is **mandatory** fitment front and rear if greasable shackles are not fitted. Note: Spring Caster Wedge OMECW2 (2° Caster Wedges) may be required to restore positive caster angle. Front end alignment check will indicate required adjustment.
- 4** There can be 2 spigot sizes of the rear fixed end pins. Check spigot size before ordering greasable pins.
50mm spigot = OMEGP2
51mm spigot = OMEGP4
- 5** When remaining stock of N85 and N92 is exhausted no further product will be available.
- 6** D2XL extra leaf and UCB2 centre bolt are suitable for CS004RA/B springs.

LANDCRUISER 60, 61 & 62 SERIES

FRONT <i>Estimated Lift: 50mm</i>	PETROL ENGINE			DIESEL ENGINE		
	PART NUMBER	QTY	UNIT PRICE \$	PART NUMBER	QTY	UNIT PRICE \$
SPRING: TO 50 KGS	CS003F 1 2 7			CS004F 1 2 7		
NITROCHARGER SPORT	60009	2		60009	2	
NITROCHARGER	N92 8			-	-	
SPRING: 51 TO 110 KGS	CS004F 1 2 7			CS005F 1 2		
NITROCHARGER SPORT	60063	2		60063	2	
SPRING BUSH KIT	OMESB1	2		OMESB1	2	
U BOLTS	OMEU51	4		OMEU51	4	
GREASABLE SHACKLE KIT	OMEGS2	1		OMEGS2	1	
GREASABLE SHACKLE FIXED END PIN KIT	OMEGP1			OMEGP1		
STEERING DAMPER	OMESD24			OMESD24		
ANTI INVERSION KIT	FK08 2			FK08 2		
EXTRA LEAF	D1XL 7	2		D1XL 7	2	
CENTRE BOLT	UCB3			UCB3		

REAR <i>Estimated Lift: 50mm</i>	ALL MODELS		
	PART NUMBER	QTY	UNIT PRICE \$
SPRING: RIDE/LIGHT LOAD	CS017RA / B 2 5	1 + 1	
NITROCHARGER SPORT	60032 3	2	
NITROCHARGER	N94 3 8		
SPRING: MEDIUM LOAD	CS004RA / B 2 5 6	1 + 1	
NITROCHARGER SPORT	*60064 / 60032 3	2	
	*60065 / 60062		
NITROCHARGER	N90 8 3		
	*N42 / N89		
FITTING KIT	FK0422 4	1	
	FK0411		
SPRING: CONSTANT 200 KGS	CS005RA / B 2 5 6	1 + 1	
NITROCHARGER SPORT	60064 3	2	
	60065		
NITROCHARGER	N90 8 3		
	N42		
FITTING KIT	FK0418 4	1	
SPRING BUSH KIT	OMESB1	2	
U BOLTS	OMEU59B	4	
GREASABLE SHACKLE KIT	OMEGS1	1	
GREASABLE SHACKLE FIXED END PIN KIT	OMEGP1		
ANTI INVERSION KIT	FK08 2		
EXTRA LEAF	D2XL 6	2	
CENTRE BOLT	UCB2		

REMARKS:

- 1** Front bump stop measurement must not exceed 100mm to ensure good shackle angle. To reduce bump stop gap, remove the 4th leaf from the top of the spring. OMECW2 Caster Wedge Kit may be required to restore correct caster angle.
- 2** Shackles: FK08 Anti Inversion Kit is **mandatory** fitment if greasable shackles are not fitted. Refer OME Technical & Fitting Manual.
- 3** Post 1986 vehicles have a 19mm mounting pin and suit shock part no's N94⁸, N90⁸, N85⁸, 60062 & 60065. Pre 1986 vehicles have a 16mm mounting pin and suit shock part no's N95⁸, N42, N89, 60032 & 60064.
- 4** Fitting Kit is only required on vehicles with rubber insulators around rear springs. Refer OME Technical & Fitting Manual Section 7 GFI: LandCruiser 60 Series page 7 selection chart.
- 5** Barn door Models may require A/A or B/B spring fitment. USA LHD Models require A/A or B/B spring fitment.
- 6** D2XL only suitable for CS004RA/B & CS005RA/B.
- 7** D1XL only suitable for CS003F & CS004F.
- 8** When remaining stock of N85, N90, N92, N94 and N95 is exhausted no further product will be available.

LANDCRUISER 45, 47 SERIES ALL LWB MODELS

FRONT <i>Estimated Lift: 35mm</i>	PETROL & DIESEL ENGINES		
	PART NUMBER	QTY	UNIT PRICE \$
SPRING: TO 50 KGS	CS001F 1		
NITROCHARGER SPORT	60097	2	
NITROCHARGER	N81		
SPRING: 51 TO 110 KGS	CS002F 1		
NITROCHARGER SPORT	60097	2	
NITROCHARGER	*N41 / N81		
SPRING BUSH KIT	See Chart Below	2	
U BOLTS - 25mm Eye Spring	OMEU59A	3	
	OMEU59B	1	
U BOLTS - 35mm Eye Spring	OMEU59A	3	
	OMEU55	1	
GREASABLE SHACKLE KITS	See Chart Below		
STEERING DAMPER	OMESD23		
ANTI INVERSION KIT	FK08 1	1	
EXTRA LEAF	D3XL		
CENTRE BOLT	UCB8	2	

REMARKS:

- 1** FK08 Anti Inversion Kit is **mandatory** fitment front and rear if greasable shackles are not fitted.
- 2** Remove 3rd leaf from CS003R spring stack to reduce spring rate for light duty application. Include tray weight in constant load calculation.

REAR <i>Estimated Lift: 50mm</i>	ALL MODELS		
	PART NUMBER	QTY	UNIT PRICE \$
SPRING: MEDIUM LOAD	CS003R 1 2		
NITROCHARGER SPORT	60032	2	
NITROCHARGER	N42		
SPRING: CONSTANT 400 KGS	CS003R 1 2		
NITROCHARGER SPORT	60064	2	
NITROCHARGER	N42		
SPRING BUSH KIT	See Chart Below	2	
U BOLTS	OMEU59B	4	
TRIM PACKER	TP02		
GREASABLE SHACKLE KITS	See Chart Below		
ANTI INVERSION KIT	FK08 1	1	
EXTRA LEAF	D8XL		
CENTRE BOLT	UCB4	2	

GREASABLE SHACKLES						
FRONT	KIT PART NO.	QTY	UNIT PRICE \$	COMPATIBLE BUSH KIT	QTY	UNIT PRICE \$
18mm Shackle Pins & 35mm Hanger Bracket	OMEGS2	1		OMESB1	2	
	OME GP1					
15mm Shackle Pins & 25mm Hanger Bracket	OMEGS8	1		OMESB30	2	
	OME GP8					
REAR						
18mm Shackle Pins & 30mm Hanger Bracket	OMEGS17	1		OMESB79	2	
	*GSP02	2				
15mm Shackle Pins & 25mm Hanger Bracket	OMEGS9	1		OMESB30	2	
	OME GP8					

* GSP02 is only a greasable pin replacement for original pin.

LANDCRUISER 40, 42 SERIES SWB

FRONT <i>Estimated Lift: 35mm</i>	PETROL & DIESEL ENGINES		
	PART NUMBER	QTY	UNIT PRICE \$
SPRING: TO 50 KGS	CS001F [2]		
NITROCHARGER SPORT	60097	2	
NITROCHARGER	N81		
SPRING: 51 TO 110 KGS	CS002F [2]		
NITROCHARGER SPORT	60097	2	
NITROCHARGER	N41		
SPRING BUSH KIT	OMESB30	2	
	OMESB1		
U BOLTS - 25mm Eye Spring	OMEU59A	3	
	OMEU59B	1	
U BOLTS - 35mm Eye Spring	OMEU59A	3	
	OMEU55	1	
GREASABLE SHACKLE KITS	See Chart Below		
STEERING DAMPER	OMESD23		
ANTI INVERSION KIT	FK08	1	
EXTRA LEAF	D3XL	2	
CENTRE BOLT	UCB8		

REMARKS:

- 1** OMESB30 suits 35mm spring eye and 25mm hanger bracket with 15mm shackle pin hole.
- OMESB1 suits 35mm spring eye and hanger bracket with 18mm shackle pin hole.
- 2** FK08 Anti Inversion Kit is mandatory fitment front and rear if greasable shackles are not fitted.
- 3** 1975 and newer FJ 40's may need to use N76 shocks in rear:
Pre 1975 shock eye in the top of the axle housing: Use N89 / N95⁴ / 60032 / 60064
Post 1975 lower shock eye is below leaf spring: Use N76 with OMEB11 Bush Kit
- 4** When remaining stock of N95 is exhausted no further product will be available.

REAR <i>Estimated Lift: 50mm</i>	ALL MODELS		
	PART NUMBER	QTY	UNIT PRICE \$
SPRING: MEDIUM LOAD	CS001R [2]		
NITROCHARGER SPORT	60032	2	
NITROCHARGER	N89		
SPRING: CONSTANT 150 KGS	CS002R [2]		
NITROCHARGER SPORT	*60064 / 60032	2	
NITROCHARGER	N89		
U BOLTS	OMEU59A	4	
SPRING BUSH KIT	OMESB30	2	
	OMESB1		
GREASABLE SHACKLE KITS	See Chart Below		
ANTI INVERSION KIT	FK08	1	
EXTRA LEAF	D4XL	2	
CENTRE BOLT	UCB8		

GREASABLE SHACKLES						
FRONT	KIT PART NO.	QTY	UNIT PRICE \$	COMPATIBLE BUSH KIT	QTY	UNIT PRICE \$
18mm Shackle Pin	OMEGS2	1		OMESB1	2	
	OMEGP1					
15mm Shackle Pin	OMEGS8	1		OMESB30	2	
	OMEGP8					
REAR						
18mm Shackle Pin	OMEGS1	1		OMESB1	2	
	OMEGP1					
15mm Shackle Pin	OMEGS9	1		OMESB30	2	
	OMEGP8					

TACOMA 2016 ON

FRONT				
<i>Estimated Lift: 50mm</i>		PART NUMBER	QTY	UNIT PRICE \$
SPRING: NO BAR		2887	1	
STRUT SPORT		90021 1	2	
SPRING: BAR ONLY		2888	1	
STRUT SPORT		*90000 / 90021 1	2	
SPRING: BAR & WINCH		2886	1	
STRUT SPORT		90000 1	2	
TRIM PACKER		OME95PF5		
UPPER STRUT BUSHES		OME3133 1		
STRUT TOP HAT KIT		OMETH002 2		
BP-51 SELECTION				
COIL OVER TACOMA FRONT LH		BP5190006L	1	
COIL OVER TACOMA FRONT RH		BP5190006R		
BP KIT TACOMA FRONT		VM80010016		
REAR				
<i>Estimated Lift: 50mm</i>		PART NUMBER	QTY	UNIT PRICE \$
SPRING: MEDIUM LOAD		EL095R	2	
NITROCHARGER SPORT		60091		
SPRING: CONSTANT 300 KGS		EL096R	2	
NITROCHARGER SPORT		60091		
EXTRA LEAF		EL46XL	2	
U BOLT		OMEU53B	4	
SPRING BUSH KIT		OMESB108	2	
DRIVESHAFT SPACER KIT		FK29	1	
BP-51 SELECTION				
SHOCK ABSORBER TACOMA REAR LH		BP5160011L	1	
SHOCK ABSORBER TACOMA REAR RH		BP5160011R		
BP KIT TACOMA REAR		VM80010017		

REMARKS:

- 1** No top mounting bushes supplied, use OME3133. OE bushes may be re-used if in good condition.
- 2** Strut Top Hat Kit may be required if original equipment is worn.

TACOMA V6 2005 TO 2015

FRONT			
<i>Estimated Lift: 50mm</i>		PART NUMBER	QTY
		UNIT PRICE \$	
SPRING: TO 50 KGS	2885	1	
NITROCHARGER SPORT	*90000 / 90021 1	2	
STRUT	N140S		
SPRING: 51 TO 100 KGS	2886	1	
NITROCHARGER SPORT	90000 1	2	
STRUT	N140S		
UPPER STRUT BUSHES	OME3133 1		
STRUT TOP HAT KIT	OMETH002 2		
BP-51 SELECTION			
COIL OVER TACOMA FRONT LH	BP5190006L	1	
COIL OVER TACOMA FRONT RH	BP5190006R		
BP KIT TACOMA FRONT	VM80010016		

REMARKS:

- 1** No top mounting bushes supplied, use OME3133. OE bushes may be re-used if in good condition.
- 2** Strut Top Hat Kit may be required if original equipment is worn.

REAR		ALL MODELS	
<i>Estimated Lift: 50mm</i>		PART NUMBER	QTY
		UNIT PRICE \$	
SPRING: MEDIUM LOAD	EL095R	2	
NITROCHARGER SPORT	60091		
SPRING: CONSTANT 300 KGS	EL096R	2	
NITROCHARGER SPORT	60091		
EXTRA LEAF	EL46XL	2	
CENTRE BOLT	UCB17		
U BOLT	OMEU53B	4	
SPRING BUSH KIT	OMESB108	2	
DRIVESHAFT SPACER KIT	FK29	1	
BP-51 SELECTION			
SHOCK ABSORBER TACOMA REAR LH	BP5160011L	1	
SHOCK ABSORBER TACOMA REAR RH	BP5160011R		
BP KIT TACOMA REAR	VM80010017		

TACOMA V6 & 4 CYLINDER 1998 TO 2004

FRONT			
<i>Estimated Lift: 45mm</i>		PART NUMBER	QTY
		UNIT PRICE \$	
SPRING: TO 50 KGS	2880	1	
NITROCHARGER SPORT	90004	2	
STRUT	N91SC 3		
SPRING: 51 TO 100 KGS	2881	1	
NITROCHARGER SPORT	90004	2	

REMARKS:

- 1** OMESB88 **must** be used with OMEGS12 greasable shackles.
OMESB89 **must** be used with original shackles.
- 2** FK21 Exhaust Bracket is **mandatory** fitment to ensure exhaust system clears springs.
- 3** When remaining stock of N85 and N91SC is exhausted no further product will be available.

REAR		ALL MODELS	
<i>Estimated Lift: 55mm</i>		PART NUMBER	QTY
		UNIT PRICE \$	
SPRING: MEDIUM LOAD	CS046RA / B 2	1 + 1	
NITROCHARGER SPORT	*60065 / 60062	2	
EXTRA LEAF	D43XL	2	
SPRING BUSH KIT	OMESB88 1		
	OMESB89		
GREASABLE SHACKLE KIT	OMEGS12 1	1	
EXHAUST BRACKET KIT	FK21 2		

HILUX 2015 ON ALL MODELS

FRONT <i>Estimated Lift: 40mm</i>	DIESEL ENGINES		
	PART NUMBER	QTY	UNIT PRICE \$
SPRING: NO BAR	2869 1	1	
STRUT - SPORT	90028 2	2	
SPRING: BAR ONLY	2884 1	1	
STRUT - SPORT	90028 2	2	
SPRING: BAR & WINCH	2885 1	1	
STRUT - SPORT	90029 2	2	
SPRING: BAR, WINCH & ACCESSORIES	2887 1	1	
STRUT - SPORT	90029 2	2	
TRIM PACKER	OME95PF5		
UPPER STRUT BUSHES	OME3133 2		
STRUT TOP HAT KIT	OMETH002 5		
BP-51 SELECTION			
COIL OVER 2015 HILUX FRONT RH	BP5190007R	1	
COIL OVER 2015 HILUX FRONT LH	BP5190007L		
BP KIT HILUX 2015 FRONT	VM80010018		

8

Use OMEU53A for EL089R and EL090R.

Use OMEU53B for EL090R with extra leaf and EL091R.

9

When adding Extra Leaf to EL091R please add UCB19.

REAR <i>Estimated Lift: 40mm</i>	ALL MODELS		
	PART NUMBER	QTY	UNIT PRICE \$
SPRING MEDIUM	EL089R 3 7 8	2	
NITROCHARGER SPORT	60132		
SPRING: CONSTANT 300 KGS	EL090R 3 7 8	2	
NITROCHARGER SPORT	*60133 / 60132		
SPRING: CONSTANT 600 KGS	EL091R 3 7 8 9	2	
NITROCHARGER SPORT	60133		
SPRING BUSH KIT	OMESB98	2	
U BOLTS	OMEU53A 8	4	
	OMEU53B		
GREASABLE SHACKLE KIT	OMEGS25	1	
EXTRA LEAF	EL45XL 4 9	2	
CENTRE BOLT FOR EL091R	UCB19		
HALOGEN HEADLAMP LEVELLING BRACKET	FK86 6	1	
LEAF SPRING FRONT EYE BOLT	6151539 7		
BP-51 SELECTION			
SHOCK ABSORBER 2015 HILUX REAR RH	BP5160018R	1	
SHOCK ABSORBER 2015 HILUX REAR LH	BP5160018L		
BP KIT HILUX 2015 REAR	VM80010019		

REMARKS:

- 1** To maintain coil clearance from the sway bar, the coil seat must be installed with the helix facing away from the sway bar.
- 5** No top mounting bushes supplied use OME3133. OE bushes may be re-used if in good condition.
- 3** Include tray weight in constant load calculation.
- 4** EL45XL will give approximately 20mm extra lift or increase loading capacity at design height by approximately 200kgs.
Strut Top Hat Kit may be required if original equipment is worn.
- 6** The Halogen Headlamp Levelling Bracket is a mandatory fitment for SR5 versions only.
- 7** Leaf Spring front eye bolt 6151539 required for fuel tank side and is available as a spare part. Refer to the Spare Parts Price List for pricing.

HILUX/VIGO 2005 TO 2015 ALL MODELS

FRONT <i>Estimated Lift: 30mm</i>	DIESEL ENGINES			PETROL ENGINES		
	PART NUMBER	QTY	UNIT PRICE \$	PART NUMBER	QTY	UNIT PRICE \$
SPRING: NO BAR	2883 1	1		3058 1	1	
STRUT - SPORT	*90002 / 90011 2	2		*90002 / 90011 2	2	
STRUT	*N167S / N166S			*N167S / N166S		
SPRING: BAR ONLY	2884 1	1		2883 1	1	
STRUT - SPORT	90002 2	2		*90002 / 90011 2	2	
STRUT	N167S			*N167S / N166S		
SPRING: BAR & WINCH	2885 1	1		2884 1	1	
STRUT - SPORT	90002 2	2		90002 2	2	
STRUT	N167S			N167S		
TRIM PACKER	OME95PF5			OME95PF5		
UPPER STRUT BUSHES	OME3133 2	2		OME3133 2	2	
STRUT TOP HAT KIT	OMETH002 5	2		OMETH002 5	2	
BP-51 SELECTION - ALL MODELS						
COIL OVER HILUX FRONT LH	BP5190001L	1				
COIL OVER HILUX FRONT RH	BP5190001R					
BP KIT HILUX FRONT	VM80010001					
REAR <i>Estimated Lift: 45mm</i>	ALL MODELS					
	PART NUMBER	QTY	UNIT PRICE \$			
SPRING: LOW LIFT 20mm	CS043R-15 3	2				
NITROCHARGER SPORT	60006					
NITROCHARGER	N168					
SPRING: LIGHT LOAD	EL043R 3	2				
NITROCHARGER SPORT	60006					
NITROCHARGER	N168					
SPRING: MEDIUM LOAD	EL044R 3	2				
NITROCHARGER SPORT	60006					
NITROCHARGER	*N169 / N168 6					
SPRING: CONSTANT 400 KGS	EL045R 3	2				
NITROCHARGER SPORT	60007					
NITROCHARGER	N169 6					
SPRING: CONSTANT 600 KGS	EL071R 3	2				
NITROCHARGER SPORT	60007					
NITROCHARGER	N169 6					
SPRING BUSH KIT	OMESB98	2				
U BOLTS	OMEU53A	4				
GREASABLE SHACKLE KIT	OMEKS14 7	1				
BRAKE PROPORTIONING BRACKET	FK59					
EXTRA LEAF	EL13XL 4	2				
BP-51 SELECTION						
SHOCK ABSORBER HILUX REAR LH	BP5160024L	1				
SHOCK ABSORBER HILUX REAR RH	BP5160024R					
BP KIT HILUX REAR	VM80010002					

REMARKS:

- 1 To maintain coil clearance from the sway bar, the coil seat **must** be installed with the helix facing away from the sway bar.
- 2 No top mounting bushes supplied, use OME3133. OE bushes may be re-used if in good condition.
- 3 Include tray weight in constant load calculation.
- 4 EL13XL will give approximately 22mm extra lift or increase loading capacity at design height by approximately 200kgs.
- 5 Strut Top Hat Kit may be required if original equipment is worn.
- 6 When remaining stock of N169 is exhausted no further product will be available.
- 7 Vehicles with Long Range fuel tank may have clearance problems if OME Greasable Shackle Kits are installed. Additional installation charges may be incurred.

HILUX/TIGER 1997 TO 2004 ALL MODELS

FRONT	PETROL & DIESEL ENGINES		
	PART NUMBER	QTY	UNIT PRICE \$
TORSION BARS: OVER 50 KGS	303003 1	1	
NITROCHARGER SPORT	60042	2	
STEERING DAMPER	OMESD33	1	

REAR <i>Estimated Lift: 50mm</i>	ALL MODELS		
	PART NUMBER	QTY	UNIT PRICE \$
SPRING: MEDIUM LOAD	CS018R 3 5	2	
NITROCHARGER SPORT	60043 + 60044 2	1 + 1	
SPRING: CONSTANT 120 KGS	CS019R 3 5	2	
NITROCHARGER SPORT	60043 + 60044 2	1 + 1	
SPRING: CONSTANT 250 KGS	CS020R 3 5	2	
NITROCHARGER SPORT	60043 + 60044 2	1 + 1	
SPRING: CONSTANT 400 KGS	CS021R 3 5	2	
NITROCHARGER SPORT	60043 + 60044 2	1 + 1	
SPRING BUSH KIT	OMESB43	2	
GREASABLE SHACKLE KIT	OMECS7 3	1	
ANTI INVERSION KIT	FK15		
U BOLT	OMEU53A	4	
FITTING KIT	FK01 4	1	
EXTRA LEAF	D6XL 6	2	
CENTRE BOLT	UCB6		

REMARKS:

- 1** Raise or lower front end clearance and trim vehicle by adjusting front torsion bars.
- 2** 60043 is longer in length and **must** be fitted to right hand side only. Fitment to left hand side may cause damage to shock absorber and vehicle.
- 3** **Mandatory** Fitment: Either OMECS7 or FK15 Anti Inversion Kit required to prevent possible spring inversion.
- 4** Fitment of FK01 Spacer Washers to U bolts is **required** to ensure correct tension is obtained on U bolts.
- 5** Include tray weight in constant load calculation.
- 6** D6XL suitable for CS019R, CS020R and CS021R.

HILUX & 4 RUNNER PRE 1997 ALL LEAF SPRING MODELS

FRONT <i>Estimated Lift: 45mm</i>	PETROL ENGINES			DIESEL ENGINES		
	PART NUMBER	QTY	UNIT PRICE \$	PART NUMBER	QTY	UNIT PRICE \$
SPRING: TO 50 KGS	CS008FA / B 1 2 3	1 + 1		CS009FA / B 1 2 3	1 + 1	
NITROCHARGER SPORT	60061	2		60061	2	
SPRING: 51 TO 110 KGS	CS009FA / B 1 2 3	1 + 1		CS009FA / B 1 2 3	1 + 1	
NITROCHARGER SPORT	60061	2		60061	2	
SPRING BUSH KIT	OMESB5	2		OMESB5	2	
U BOLTS	OMEU52 + 3	1 +		OMEU52 + 3	1 +	
	OMEU53 +	2 +		OMEU53 +	2 +	
	OMEU53B	1		OMEU53B	1	
FITTING KIT	FK03 2	1		FK10 2	2	
GREASABLE SHACKLE KIT	OMEGS4			OMEGS4	1	
GREASABLE SHACKLE FIXED END PIN KIT	OMEGP3			OMEGP3		
STEERING DAMPER	OMESD21			OMESD21		
EXTRA LEAF	D17XL 9		2		D17XL 9	2
CENTRE BOLT	UCB7			UCB7		

REAR <i>Estimated Lift: 50mm</i>	ALL MODELS		
	PART NUMBER	QTY	UNIT PRICE \$
SPRING: MEDIUM LOAD	CS009R 4 6 7	2	
NITROCHARGER SPORT	*60064 / 60032 5		
	*60065 / 60062 5		
NITROCHARGER	N94 8	2	
	N89 5		
SPRING: CONSTANT 250 KGS	CS010R 4 6 7	2	
NITROCHARGER SPORT	60064 5		
	60065 5		
NITROCHARGER	N89 5		
U BOLTS	OMEU53	4	
SPRING BUSH KIT	OMESB6	2	
GREASABLE SHACKLE KIT	OMEGS3	1	
GREASABLE SHACKLE FIXED END PIN KIT	OMEGP3		
TRIM PACKER	TP04 4		
ANTI INVERSION KIT	FK09 6	1	
	FK13		
EXTRA LEAF	D5XL	2	
CENTRE BOLT	UCB6		

REMARKS:

- 1 A/A spring fitment may be needed on some vehicles for trimming purposes.
- 2 Petrol HiLux may require FK03 (Saddle Correction Plates) if the spring seats are distorted. FK10 must be fitted to all Diesel & Petrol Models used off road. Refer OME Technical & Fitting Manual.
- 3 OMEU52 is required when fitting OME springs to stop the U bolt contacting the drag link. Refer OME Technical & Fitting Manual. OMEU52 and OMEU53B for drivers side. OMEU53 for passenger side.
- 4 A trim packer may be required to trim vehicle. Only to be used on rear springs.
- 5 Post 1984 vehicles have a 19mm mounting pin and suit shock part numbers: N85⁸, N94⁸, 60062 and 60065. Pre 1984 vehicles have a 16mm mounting pin and suit shock part numbers: N89, N95⁸, 60032 and 60064.
- 6 If greasable shackles are not fitted Anti Inversion Kits must be fitted. FK09 fits all pre 1984 Models. FK13 fits all 1985 Models On.
- 7 Include tray weight in constant load calculation. To provide correct shackle angle, 1985 - 89 automatic 4 Runner Models require the 3rd leaf to be removed to reduce spring rate.
- 8 When remaining stock of N85, N94 and N95 is exhausted no further product will be available.
- 9 Only Suits CS008FA/B. **Do not** fit to CS009FA/B.

HILUX PRE 1997 EXTRA CAB & DUAL CAB SR5 IFS & REAR LEAF MODELS

FRONT	PETROL & DIESEL ENGINES		
	PART NUMBER	QTY	UNIT PRICE \$
TORSION BARS: 50 KGS	303003 1	1	
NITROCHARGER SPORT	60072	2	
STEERING DAMPER	OMESD33	1	

REAR <i>Estimated Lift: 50mm</i>	ALL MODELS		
	PART NUMBER	QTY	UNIT PRICE \$
SPRING: MEDIUM LOAD	CS019R 2 3	2	
NITROCHARGER SPORT	60065		
NITROCHARGER	N94 4		
SPRING: CONSTANT 200 KGS	CS020R 2 3	2	
NITROCHARGER SPORT	60065		
NITROCHARGER	N94 4		
SPRING BUSH KIT	OMESB43	2	
U BOLTS	OMEU53 2	4	
	OMEU53B		
GREASABLE SHACKLE KIT	OMECS7	1	
EXTRA LEAF	D6XL	2	
CENTRE BOLT	UCB6		

REMARKS:

- 1** Raise or lower front end clearance and trim vehicle by adjusting front torsion bars.
- 2** Compare original spring stack height to OME spring stack to decide whether OMEU53 or OMEU53B U bolts are required.
- 3** Include tray weight in constant load calculation.
- 4** When remaining stock of N85 and N94 is exhausted no further product will be available.

4 RUNNER 2010 ON (USA MODEL)

FRONT <i>Estimated Lift: 50mm</i>	V6 4.0L PETROL ENGINE		
	PART NUMBER	QTY	UNIT PRICE \$
SPRING: NO BAR	2883	1	1
STRUT - SPORT	90010	2	2
SPRING: BAR ONLY	2884	1	1
STRUT - SPORT	90010	2	2
SPRING: BAR AND WINCH	2885	1	1
STRUT - SPORT	90010	2	2
TRIM PACKER	OME95PF5	1	
UPPER STRUT BUSHES	OME3133	2	
STRUT TOP HAT KIT	OMETH002	4	
BP-51 SELECTION - NON KDSS MODELS			
BP-51 COIL OVER FRONT RH	BP5190002R	1	
BP-51 COIL OVER FRONT LH	BP5190002L		
BP-51 FIT KIT FRONT	VM80010028		
BP-51 SELECTION - KDSS MODELS			
BP-51 COIL OVER FRONT LH	BP5190004L	1	
BP-51 COIL OVER FRONT RH	BP5190002R		
BP-51 FIT KIT FRONT	VM80010009		
REAR <i>Estimated Lift: 50mm</i>	LWB MODEL		
	PART NUMBER	QTY	UNIT PRICE \$
SPRING: MEDIUM LOAD	2895	1	1
NITROCHARGER SPORT	60080	2	
SPRING: CONSTANT 200 KGS	2896	1	1
NITROCHARGER SPORT	*60081 / 60080	2	
SPRING: CONSTANT 400 KGS	2897	1	1
NITROCHARGER SPORT	60081	2	
TRIM PACKER	OME150PR10	3	
STONE GUARD KIT	OME661	1	
BP-51 SELECTION			
BP-51 SHOCK REAR	BP5160025	2	
BP-51 FIT KIT REAR	VM80010010	1	

REMARKS:

- 1** Vehicles with KDSS, must have 1 x OME95PF5 packer installed on the front right hand side to maintain correct trim.
- 2** No top mounting bushes supplied, use OME3133. OE bushes may be re-used if in good condition.
- 3** OME661 Lower Shock Mount Stone Guard is recommended fitment to rear shocks to protect against severe stone peppering encountered on loose road surfaces.
- 4** Strut Top Hat Kit may be required if original equipment is worn.

4 RUNNER 2003 TO 2010 (USA MODEL)

FRONT <i>Estimated Lift: 25-50mm</i>			
	PART NUMBER	QTY	UNIT PRICE \$
SPRING: NO BAR	2884 1	1	
STRUT - SPORT	90000 2	2	
STRUT	N140S		
SPRING: TO 75 KGS	2885 1	1	
STRUT - SPORT	90000 2	2	
STRUT	N140S		
TRIM PACKER	OME95PF5		
UPPER STRUT BUSHES	OME3133 2		
STRUT TOP HAT KIT	OMETH002 3		

REAR <i>Estimated Lift: 50mm</i>			
	PART NUMBER	QTY	UNIT PRICE \$
SPRING: MEDIUM LOAD	2895	1	
NITROCHARGER SPORT	60004	2	
NITROCHARGER	N141		
SPRING: CONSTANT 150 KGS	2896	1	
NITROCHARGER SPORT	*60005 / 60004	2	
SPRING: CONSTANT 300 KGS	2897	1	
NITROCHARGER SPORT	60005	2	
STONE GUARD KIT	OME661	1	

REMARKS:

- 1** OME front coils can only be installed with OME Nitrocharger strut and coil seats.
- 2** No top mounting bushes supplied, use OME3133. OE bushes may be re-used if in good condition.
- 3** Strut Top Hat Kit may be required if original equipment is worn.

4 RUNNER/TOYOTA SURF 1996 TO 2002 (USA MODEL)

FRONT <i>Estimated Lift: 30mm</i>	PETROL & DIESEL ENGINES		
	PART NUMBER	QTY	UNIT PRICE \$
SPRING: TO 50KGS	2880	1	
SPRING: 51 TO 100KGS	2881	1	
NITROCHARGER SPORT	90004	2	

REAR <i>Estimated Lift: 50mm</i>	ALL MODELS		
	PART NUMBER	QTY	UNIT PRICE \$
SPRING: MEDIUM LOAD	2906	1	
SPRING: CONSTANT 250KGS	2890	1	
NITROCHARGER SPORT	*60027 / 60028	2	
NITROCHARGER	N86		

4 RUNNER 1990 TO 1996 (TO 1995 IN USA)

IFS REAR COIL SPRING MODELS

FRONT	PETROL & DIESEL ENGINES		
	PART NUMBER	QTY	UNIT PRICE \$
TORSION BARS: OVER 50 KGS	303003 1	1	
NITROCHARGER SPORT	60072	2	
STEERING DAMPER	OMESD33	1	

REMARKS:

- 1 Raise or lower front end clearance and trim vehicle by adjusting front torsion bars.
- 2 When remaining stock of N72F is exhausted no further product will be available.

REAR <i>Estimated Lift: 40mm</i>	ALL MODELS		
	PART NUMBER	QTY	UNIT PRICE \$
SPRING: MEDIUM LOAD	2900	1	
NITROCHARGER SPORT	60073	2	
NITROCHARGER	N72F 2		
SPRING: CONSTANT 150 KGS	2901	1	
NITROCHARGER SPORT	60073	2	
NITROCHARGER	N72F 2		

4 RUNNER 1986 TO 1990 (TO 1989 IN USA)

IFS REAR LEAF SPRING MODELS

FRONT	PETROL & DIESEL ENGINES		
	PART NUMBER	QTY	UNIT PRICE \$
TORSION BARS: OVER 50 KGS	303003 1	1	
NITROCHARGER SPORT	60072	2	
STEERING DAMPER	OMESD33	1	

REMARKS:

- 1 Raise or lower front end clearance and trim vehicle by adjusting front torsion bars.
- 2 Compare original spring stack height to OME spring stack to decide whether OMEU53 or OMEU53B U bolts are required.
- 3 Install OE caster wedges from OE spring stack onto OME springs. Ensure wedges are fitted as per original position.
- 4 When remaining stock of N85 and N94 is exhausted no further product will be available.

REAR <i>Estimated Lift: 50mm</i>	ALL MODELS		
	PART NUMBER	QTY	UNIT PRICE \$
SPRING: MEDIUM LOAD	CS009R 2 3	2	
NITROCHARGER SPORT	60065		
NITROCHARGER	N94 4		
SPRING: CONSTANT 200 KGS	CS010R 2 3	2	
NITROCHARGER SPORT	60065		
SPRING BUSH KIT	OMESB6	2	
U BOLTS	OMEU53 2	4	
	OMEU53B		
GREASABLE SHACKLE KIT	OMEGS3	1	
GREASABLE SHACKLE FIXED END PIN KIT	OMEGP3		
EXTRA LEAF	D5XL	2	
CENTRE BOLT	UCB6		

AMAROK 2010 ON ALL MODELS

FRONT <i>Estimated Lift: 20mm</i>	4 CYLINDER DIESEL ENGINE			V6 DIESEL ENGINE		
	PART NUMBER	QTY	UNIT PRICE \$	PART NUMBER	QTY	UNIT PRICE \$
SPRING: NO BAR	3079	1		3080	1	
STRUT - SPORT	90012 1 2 7	2		90013 1 2 7	2	
SPRING: BAR	3080	1		3115	1	
STRUT - SPORT	90013 1 2 7	2		90013 1 2 7	2	
SPRING: BAR & WINCH	3080 6	1		3116	1	
STRUT - SPORT	90013 1 2 7	2		90013 1 2 7	2	
TRIM PACKER	OME95PF5 2 6			OME95PF5 2		

REAR <i>Estimated Lift: 20mm</i>	DIESEL ENGINE		
	PART NUMBER	QTY	UNIT PRICE \$
SPRING: MEDIUM LOAD	CS064R 3	2	
NITROCHARGER SPORT	60082 4		
SPRING: CONSTANT 400 KGS	CS065R 3	2	
NITROCHARGER SPORT	60083 4		
SPRING BUSH KIT	OMESB104 3	2	
STONE GUARD KIT	OME665 4	1	
U BOLTS	- MEDIUM SPRING - CONSTANT 400KGS SPRING	4	
	OMEU59A OMEU59B		
EXTRA LEAF	D38XL 5	2	
CENTRE BOLT	UCB17		

REMARKS:

- 1** Top mount bump stop and bushes not supplied, re-use OE items.
- 2** For trimming purposes only, maximum 1 packer per strut.
- 3** Workshop fitting kit FK33 recommended for easier bush install (note: one FK33 kit required per workshop).
- 4** OME665 Lower Shock Mount Stone Guard is **mandatory** fitment to rear shocks to protect against severe stone peppering encountered on loose road surfaces.
- 5** D38XL will give approximately 12mm extra lift or increase loading capacity at design height by approximately 160kgs.
- 6** To achieve 20mm lift for bar and winch, OME95PF5 will need to be fitted with 3080 coil.
- 7** Volkswagen Service Manual quotes that driveshaft bolts are a one use only. It is recommended to replace bolts. Replacement bolts Volkswagen Part Number **N90991102** are to be sourced separately.

Fitting Time: Due to the complexity of installation allow 5 hours for complete install.

SUSPENSION BUSH KIT SELECTION

MODEL	YEAR	LOCN	DESCRIPTION	OME P/NO.	KITS REQ	BUSHES IN KITS	DIAGRAM #	NOTE
DAIHATSU								
F Series All Models	5/93 on	F	Sway bar - link lower	¹ OMESB2360	1	4	7	
		R	Sway bar - link upper	¹ OMESB2360	1	4	7	
Feroza All Models	10/88 on	F	Sway bar - link inner/outer	¹ OMESB2360	2	4	7	
Rocky All Models	4/84 to 93	F	Sway bar - link eye	OMESB0052	1	4	7	
FORD								
Courier All Models	1/87 on	F	Sway bar - link	OMESB2361	1	4	2	
		R	Spring bush	OMESB82	2	6	4	
Maverick SWB & Wagon Models	8/87 to 9/93	F	Caster Kit	OMECA77B	1	4	8	
			Coil Packer - 5mm	OMEGQPF05			8	
			Coil Packer - 10mm	OMEGQPF10			8	
			Control arm - to diff front/centre (std)	OMESB0055	1	8	8	
			Control arm - to chassis	OMESB0056	1	4	8	
			Panhard rod	OMESB0054	1	4	8	
			Sway bar - D mount (15mm)	OMESB2365	1	2	8	
			Sway bar - link	OMESB2379	1	8	8	
		R	Coil Packer - 5mm	OMEGQPR05	1		9	
			Coil Packer - 10mm	OMEGQPR10	1		9	
			Control arm - upper	OMESB0062	1	8	9	
			Control arm - lower	OMESB0061	1	8	9	
			Panhard rod	OMESB0054	1	4	9	
			Sway bar - link	OMESB2379	1	8	9	
Maverick Single Cab Models Leaf Springs			Spring & shackle bush kit	OMESB64	2	6	4	Suits OME springs only
GMH / ISUZU								
Drover	2/85 on	F	Spring bush	OMESB19	2	6	4	
		R	Spring bush	OMESB19	2	6	4	Suits OE & OME springs
Jackaroo / Trooper Models								
UBS 16 & 17	8/85 to 91	R	Spring & shackle bush kit	OMESB90	2	6	4	Suits OE & OME springs
Rodeo - Isuzu Pick Up Models								
All Models	81 to 87	R	Spring bush	OMESB80	2	6	4	Suits OE & OME springs
V6 Models Only	88 on	R	Spring bush	OMESB80	2	6	4	Suits OE & OME springs
LADA								
Niva	ALL	F	Coil Packer - 10mm	OMELNF10				
LAND ROVER								
Defender 90, 110 & 130, 110 Long Travel, 130 Long Travel Models	92 on	F	Caster kit	CALR2	1	4	8	Suits 44mm wide control arms
County 110 Model	84 to 92	F	Caster kit	CALR1	1	4	8	Suits 38mm wide control arms
Discovery All Models	89 to 99	F	Caster kit	CALR2	1	4	8	Suits 44mm wide control arms
Range Rover	72 to 86	F	Caster kit	CALR1	1	4	8	Suits 38mm wide control arms
Range Rover	86 to 95	F	Caster kit	CALR2	1	4	8	Suits 44mm wide control arms
MAZDA								
B2500 & B2600	3/87 to 98	F	Sway bar - link	OMESB2361	1	4	7	
B2500 & B2600		R	Spring bush	OMESB82	2	6	4	
MITSUBISHI								
Challenger PA Wagon (Rear Leaf Springs)	98 to 5/00	R	Spring bush	OMESB83	2	6	4	
Pajero								
NG	9/89 to 5/91	F	Sway bar - link inner	OMESB2361	1	4	2	Suits V6 & intercooled diesel models
NA, NB, NC, ND, NE, NF & NG	83 to 5/91	F	Sway bar - link inner/outer	¹ OMESB2360	2	4	2	Suits 4 cyl petrol & diesel models not intercooled
All Leaf Spring Models	5/91 on	R	Spring bush	OMESB8	2	6	4	
Triton								
Club Cab Model Only		F	Sway bar - link inner/outer	¹ OMESB2360	2	4	2	
		R	Spring bush	OMESB38	2	6	4	
MK Models	10/96 on	R	Spring & shackle bush kit	OMESB38	2	6	4	

1. When remaining stock of OMESB2360 is exhausted, no further product will be available.

cont.

SUSPENSION BUSH KIT SELECTION

MODEL	YEAR	LOCN	DESCRIPTION	OME P/NO.	KITS REQ	BUSHES IN KITS	DIAGRAM #	NOTE
NISSAN								
Navara D21 All	9/85 to 97	F	Sway bar - link	OMESB2379	1	8	1	
		R	Spring & shackle bush kit	OMESB81	2	6	4	
Navara D22 All	2/97 on		Sway bar - link upper	OMESB2379	1	8	1	
		R	Spring & shackle bush kit	OMESB81	2	6	4	Suits models to 8/02
		R	Spring & shackle bush kit	OMESB91	2	6	4	Suits models 10/02 on
Pathfinder All	8/86 to 94	F	Sway bar - link	OMESB2379	1	8	1	
Patrol								
MQ (Round Head Lights)	80 to 8/84	F	Spring (front eye) bush kit	OMESB28	2	2	4	Use with OMESB29/OE springs use OMESB3
MQ (Square Head Lights)	8/84 to 87	F	Spring (front eye) bush kit	OMESB31	2	2	4	Use with OMESB29 suits OME springs
MQ All Models	80 to 87	F	Spring (rear eye) bush kit	OMESB29	2	1	4	
		R	Spring & shackle bush kit	OMESB2	2	4	4	Suits OE & OME springs
			Spring bush	OMESB29	2	1	4	Suits OME springs
Y60, GQ	11/87 to 97	F	Body mount - bumper area	¹ OMESB9090	1	4		Suits wagon & hardtops, no kit available for CC
		F	Body mount - cab front	¹ OMESB9091	1	4		Suits all wagon to 11/94 & all hardtop models
		F	Body mount - cab centre	OMESB9092	1	4		Suits all wagon & hardtop models
		F	Body mount - cab front & centre	OMESB9092	2	4		Suits pick up & CC models
		F	Caster kit - Control arm	OMECA77B	1	4	8	
		F	Control arm - to axle	OMESB0055	1	8	8	
		F	Control arm - to chassis	OMESB0056	1	4	8	
		F	Spring - eye front/rear & shackle	OMESB1	2	6	4	Suits leaf spring models
		F	Panhard rod - bush	OMESB0054	1	4	8	
		F	Sway bar - link	OMESB2379	1	8	8	Suits coil spring models
		F	Coil Packer - 5mm	OMEGQPF05				
		F	Coil Packer - 10mm	OMEGQPF10				
		R	Body mount - cab rear to axle	OMESB9092	2	4		Suits all wagon models
		R	Body mount - cab rear to axle	OMESB9092	1	4		Suits all hardtop models
		R	Panhard rod - bush	OMESB0054	1	4	9	Not suitable before 9/89
		R	Spring - eye front/rear & shackle	OMESB64	2	6	4	Leaf spring models
		R	Sway bar - link	OMESB2379	1	8	9	Suits CC models with coil suspension
		R	Control arm - lower	OMESB0061	1	8	9	
		R	Control arm - upper	OMESB0062	1	8	9	
		R	Coil Packer - 5mm	OMEGQPR05				
			Coil Packer - 10mm	OMEGQPR10				
Y61, GU	10/97 on	F	Body mount - bumper area	¹ OMESB9090	1	4		Suits wagon & hardtop, no kit available for CC
		F	Body mount - cab front	¹ OMESB9091	1	4		Suits all wagon & hardtop models
			Body mount - cab centre	OMESB9092	1	4		Suits all wagon & hardtop models
		F	Body mount - cab front & centre	OMESB9092	2	4		Suits all CC models
		F	Caster kit - Control arm - to axle	OMECA77B	1	4	8	
		F	Control arm - to axle	OMESB0055	1	8	8	
		F	Control arm - to chassis	OMESB0056	1	4	8	
	10/97 on	F	Panhard rod - bush	OMESB0054	1	4	8	Suits CC all models & wagon to 02/00
		F	Sway bar - link	OMESB2379	1	8	8	Suits coil spring models to 2001
		F	Sway bar - mount 15mm	OMESB2365	1	2	8	Does not suit ZD30 wagon
		R	Body mount - cab centre to axle	OMESB9092	2	4		Suits all wagon models
			Body mount - cab centre to axle	OMESB9092	1	4		Suits all hardtop models
		R	Panhard rod - bush	OMESB0054	1	4	9	
		R	Trailing arm - lower	OMESB0061	1	8	9	

1. When remaining stock of OMESB9090 and OMESB9091 is exhausted, no further product will be available.

cont.

SUSPENSION BUSH KIT SELECTION

MODEL	YEAR	LOCN	DESCRIPTION	OME P/NO.	KITS REQ	BUSHES IN KITS	DIAGRAM #	NOTES
NISSAN (Continued)								
Patrol - cont.								
Y61, GU - cont.	10/97 on	R	Sway bar - link	OMESB2379	1	8	9	Suits CC models with coil suspension.
		R	Trailing arm - upper	OMESB0062	1	8	9	
		R	Coil Packer - 5mm	OMEGQPR05				
			Coil Packer - 10mm	OMEGQPR10				
SUZUKI								
Jimny SN413		R	Coil Packer - 10mm	OMESJR10				
LJ50	74 to 6/78	F	Spring Bush	OMESB25	2		4	Suits OE & OME springs
	74 to 6/78	R	Spring Bush	OMESB25	2		4	Suits OE & OME springs
LJ80	7/78 to 12/81	F	Spring Bush	OMESB19	2		4	Suits OE & OME springs
		R	Spring Bush	OMESB19	2		4	Suits OE & OME springs
Sierra SJ410 & SJ413	7/81 to 95	F	Spring Bush	OMESB19	2		4	Suits OE & OME springs
		R	Spring Bush	OMESB19	2		4	Suits OE & OME springs
TOYOTA								
4 Runner Leaf Spring Front & Rear								
4 Runner (Surf) LN60, YN60	7/84 to 10/85	F	Spring - bush kit	OMESB5	2	6	4	Suits OE & OME springs
		R	Spring - bush kit	OMESB6	2	6	4	Suits OE & OME springs
4 Runner IFS Front Leaf Spring Rear								
4 Runner (Surf) LN61, YN63	11/85 to 9/89	R	Spring - bush kit	OMESB6	2	6	4	Suits OE & OME springs
HiLux IFS Front & Coil Spring Rear								
4 Runner (Surf) LN130, RN130, VZN130, YN130	10/89 to 6/96	F	Sway bar - mount 25mm	OMESB0049	1	2	12	
		R	Sway bar - link	OMESB2915	1	8	7	Suits LN130, RN130 models
		R	Sway bar - link	OMESB3010	1	4	7	Suits VZN130, YN130 models
HiLux 4WD Leaf Spring Front & Rear								
HiLux (Surf) LN36, 46 RN36, 46	4/79 to 10/83	F	Spring - bush kit	OMESB5	2	6	4	Suits OE & OME springs
		F	Sway bar - link	OMESB2915	1	8	4	
		R	Spring - bush kit	OMESB6	2	6	4	Suits OE & OME springs
HiLux (Surf) LN65, YN 65, 67	11/83 to 9/88	F	Spring - bush kit	OMESB5	2	6	4	Suits OE & OME springs
		R	Spring - bush kit	OMESB6	2	6	4	Suits OE & OME springs
HiLux (Surf) RN105, LN106	10/88 to 11/97	F	Spring - bush kit	OMESB5	2	6	4	Suits OE & OME springs
		F	Sway bar - mount 25mm	OMESB0049	1	2	4	
		R	Spring - spring bush	OMESB6	2	6	4	Suits OE & OME springs
HiLux 4WD IFS Front & Leaf Spring Rear								
HiLux (Surf) LN107, 111, RN106, 110, 111	10/88 to 12/97	F	Sway bar - mount 25mm	OMESB0049	1	2	1	
		R	Spring - bush kit	OMESB43	2	6	4	Suits OME springs only
LN167, 172, RZN169, 174	11/97 on	F	Sway bar - link	OMESB2915	1	8	1	
		F	Sway bar - mount 25mm	OMESB0049	1	2	1	
		R	Spring - bush kit	OMESB43	2	6	4	Suits OME springs only
KZN165	12/99 on	F	Sway bar - link	OMESB3010	1	4	1	
		F	Sway bar - mount 25mm	OMESB0049	1	2	1	
		R	Spring - bush kit	OMESB43	2	6	4	Suits OME springs only
LandCruiser 40 Series								
BJ40, 42, FJ40, 45, JH45, 47	1969 to 12/84	F	Spring - bush kit-to suit 15mm ID	OMESB30	2	6	4	Suits 35mm spring eye
		F	Spring - bush kit-to suit 18mm ID	OMESB1	2	6	4	Suits 35mm spring eye
		R	Spring - bush kit-to suit 15mm ID	OMESB30	2	6	4	Suits 35mm spring eye
		R	Spring - bush kit-to suit 18mm ID	OMESB79	2	6	4	Suits 35mm spring eye & 30mm hanger bracket
		R	Spring - bush kit-to suit 18mm ID	OMESB1	2	6	4	Suits 35mm spring eye
LandCruiser 60 Series								
FJ60, 62, HJ60, 62	11/80 to 8/87	F	Spring - bush kit	OMESB1	2	6	4	
		F	Sway bar - link	OMESB2915	1	8	4	
		R	Spring - bush kit	OMESB1	2	6	4	Suits OE & OME springs
		R	Sway bar - mount 23mm	OMESB2327	1	2	4	
FJ62, HJ60, 61	8/87 to 12/91	F	Spring - bush kit	OMESB1	2	6	4	Suits OE & OME springs
		F	Sway bar - link	OMESB2915	1	8	4	

cont.

SUSPENSION BUSH KIT SELECTION

MODEL	YEAR	LOCN	DESCRIPTION	OME P/NO.	KITS REQ	BUSHES IN KITS	DIAGRAM #	NOTES
TOYOTA (continued)								
LandCruiser 60 Series - cont.								
FJ62, HJ60, 61 - cont.	8/87 to 12/91	F	Sway bar - mount 23mm	OMESB2327	1	2	4	Suits models to 1/90
		R	Spring - bush kit	OMESB1	2	6	4	Suits OE & OME springs
		R	Sway bar - mount 23mm	OMESB2327	1	2	4	
LandCruiser 70 Series								
Bundera (Prado NZ) LJ70, RJ70	1/85 to 12/91	F	Panhard rod - bush	¹ OMESB8133	1	4	10	Suits models to 8/87
		F	Sway bar - link	OMESB2361	2	8	10	
		F	Sway bar - mount 23mm	OMESB2327	1	2	10	Suits models 8/87 - 1/90
		F	Sway bar - mount 25mm	OMESB0049	1	2	10	
BJ70, 73, 74	1/85 to 3/90	F	Spring - bush kit	OMESB1	2	6	4	Suit OE & OME springs
		F	Sway bar - link	OMESB2361	2	8	4	
		F	Sway bar - mount 23mm	OMESB2327	1	2	4	Suits models to 5/86
		F	Sway bar - mount 23mm	¹ OMESB0063	1	2	4	Suits models 6/86 on
		R	Spring - bush kit	OMESB1	2	6	4	Suits OE & OME springs
HJ75	1/85 to 3/90	F	Spring - bush kit	OMESB1	2	6	4	Suits OE & OME springs
		F	Sway bar - link	OMESB2361	2	8	4	
		F	Sway bar - mount 23mm	OMESB2327	1	2	4	Suits models to 5/86
		F	Sway bar - mount 23mm	¹ OMESB0063	1	2	4	Suits models 6/86 on
		R	Spring - bush kit	OMESB16	2	6	4	
FJ70, 73, 75	1/85 to 10/92	F	Spring - bush kit	OMESB1	2	6	4	Suits OE & OME springs
		F	Sway bar - link	OMESB2361	2	8	4	
		F	Sway bar - mount 23mm	OMESB2327	1	2	4	Suits models to 5/86
		F	Sway bar - mount 23mm	¹ OMESB0063	1	2	4	Suits models 6/86 on
		F	Sway bar - mount 25mm	OMESB0049	1	2	4	Suits FJ75 models to 8/91
		R	Spring - bush kit	OMESB16	2	6	4	Suits FJ70, 73 models
		R	Spring - bush kit	OMESB1	2	6	4	
		R	Sway bar - mount 25mm	OMESB0095	1	2	4	Suits bracket height = 38mm
FZJ70, 75, HZJ70, 73, 75	1/88 to 11/99	F	Spring - bush kit	OMESB1	2	6	4	Suits OE & OME springs
		F	Sway bar - link	OMESB2361	2	8	4	
		F	Sway bar - mount 23mm	¹ OMESB0063	1	2	4	Suits HZJ75 models to 4/91
		F	Sway bar - mount 25mm	OMESB0049	1	2	4	Suits HZJ75 models to 4/91
		F	Sway bar - mount 25mm	OMESB0095	1	2	4	Suits 4/91 on bracket height = 38mm
		R	Spring - bush kit	OMESB16	2	6	4	Suits FJ75 models
		R	Spring - bush kit	OMESB1	2	6	4	Suits HZJ70 & 73 models
		R	Sway bar - mount 25mm	OMESB0095	1	2	4	Suits 4/91 on bracket height = 38mm
PZJ70, 73	3/90 to 2/91	F	Spring - bush kit	OMESB1	2	6	4	Suits OE & OME springs
		F	Sway bar - link	OMESB2361	1	8	4	
		R	Spring - bush kit	OMESB1	2	6	4	Suits OE & OME springs
FZJ78, 79, HDJ78, 79, HZJ78, 79	8/99 on	F	Caster kit	OMECA77B	1	4	10	Caster align offset 3 degree
		F	Control arm - to chassis	OMESB0050	1	4	10	
		F	Sway bar - link outer	OMESB2413	1	2	10	Contains new bolts, nuts & crush tubes
		F	Sway bar - mount 31mm	OMESB2414	1	2	10	
		F	Panhard rod - bush	OMESB0046	1	4	10	
		R	Sway bar - link inner	OMESB3010	1	4	8	
		R	Sway bar - link outer lower	OMESB0052	1	4	4	
		R	Sway bar - link outer upper	OMESB3010	1	4	4	
			Sway bar - mount 25mm	OMESB0095	1	2	4	Suits bracket height = 38mm
			Spring - bush kit	OMESB86	2	6	4	Suits FZJ / HDJ / HZJ78 models with OME springs
			Spring - bush kit	OMESB84	2	6	4	Suits FZJ / HDJ / HZJ79 models with OME springs

1. When remaining stock of OMESB8133 and OMESB0063 is exhausted, no further product will be available.

cont.

SUSPENSION BUSH KIT SELECTION

MODEL	YEAR	LOCN	DESCRIPTION	OME P/NO.	KITS REQ	BUSHES IN KITS	DIAGRAM #	NOTES
TOYOTA (continued)								
LandCruiser 70 Series - cont.								
FZJ78, 79, HDJ78, 79, HZJ78, 79 - cont.	8/99 on		Spring - bush kit	OMESB85	2	6	4	Suits all models with OME springs & greasable shackles
LandCruiser 80 Series								
FJ80, FZJ80, HDJ80, HZJ80	1/90 to 2/98	F	Caster kit	OMECA77B	1	4	10	Caster align offset 3 degree
		F	Control arm - to chassis only	OMESB0050	1	4	10	
		F	Panhard rod - bush	OMESB0046	1	4	10	
		F	Control arm - complete kit	OMESB0045	2	6	10	
		F	Sway bar - link upper	OMESB0051	1	4	10	
		F	Sway bar - link lower	OMESB0044	1	4	10	
		F	Sway bar - mount 24mm	¹ OMESB0063	1	2	10	Suits bracket height = 35mm
		F	Sway bar - mount 26mm	¹ OMESB0094	1	2	10	Suits bracket height = 35mm
		F	Sway bar - mount 26mm	¹ OMESB0091	1	2	10	Suits bracket height = 38mm
		F	Sway bar - mount 29mm	OMESB0092	1	2	10	Suits bracket height = 38mm
		F	Coil Packer - 5mm	OME80PF05			10	
		F	Coil Packer - 10mm	OME80PF10			10	
		R	Panhard rod - bush	OMESB0053	1	4	8	
		R	Sway bar - link lower	OMESB0052	1	4	8	
		R	Sway bar - link upper	OMESB3010	1	4	8	
		R	Sway bar - mount 25mm	OMESB0049	1	2	8	Suits bracket height = 35mm
		R	Sway bar - mount 25mm	OMESB0095	1	2	8	Suits large bracket height = 38mm
		R	Control arm - lower	OMESB0047	1	8	8	
		R	Control arm - upper	OMESB0048	1	8	8	
LandCruiser 100 Series								
FZJ105, HZJ105 Solid Axle	3/98 on	F	Caster kit	OMECA77B	1	4	10	Caster align offset 3 degree
		F	Control arm - complete kit	OMESB0045	2	6	10	STD replacement
		F	Control arm - to chassis only	OMESB0050	1	4	10	
		F	Panhard rod - bush	OMESB0046	1	4	10	
		F	Sway bar - link lower	OMESB0044	1	2	10	
		F	Coil Packer - 5mm	OME80PF05				
		F	Coil Packer - 10mm	OME80PF10				
		F	Sway bar - mount 29mm	OMESB0092	1	2	10	Suits large bracket height = 38mm
		R	Sway bar - link upper	OMESB3010	1	4	8	
		R	Sway bar - link lower	OMESB0052	1	4	8	
		R	Panhard rod - bush	OMESB0053	1	4	9	
		R	Sway bar - mount 25mm	OMESB0095	1	2	8	Suits bracket height = 38mm
		R	Control arm - lower	OMESB0047	1	8	8	
		R	Control arm - upper	OMESB0048	1	8	8	
		R	Coil Packer - 5mm	OME80PR05				
		R	Coil Packer - 10mm	OME80PR10				
LandCruiser Lexus								
HDJ100, UZJ100 (Lexus) IFS	3/98 on	F	Sway bar - link upper	OMESB2361	1	4	7	
		R	Sway bar - link	OMESB2915	1	8	7	
Tacoma	2016 On	R	Spring - bush kit	OMESB108	2	4	4	
Tacoma V6	2005 To 2015	R	Spring - bush kit	OMESB108	2	4	4	
Tacoma V6 & 4 Cylinder	1998 To 2004	R	Spring bush	OMESB88	2	4	4	Suits OMEGS12 greasable shackles
		R	Spring bush	OMESB89	2	4	4	Suits original shackles only

1. When remaining stock of OMESB0063, OMESB0091 and OMESB0094 is exhausted, no further product will be

cont.

SUSPENSION BUSH KIT SELECTION

SWAY BARS	D BUSH	EYE BUSH	LINK	LINK BUSH
OMESTAB2	OMESB3020 (PR)		OMESB3012 (PR)	
OMESTAB3	OMESB3013 (PR)	OMESB3016 (PR)	N/A	N/A
OMESTAB4	OMESB3017 (PR)		N/A	N/A
OMESTAB5	OMESB3018 (PR)	OMESB3016 (PR)	OMESB3019 (EA)	OMESB3021 (PR)
OMESTAB6	OMESB3017 (PR)	OMESB3016 (PR)	OMESB3019 (EA)	OMESB3021 (PR)
OMESTAB7				
OMESTAB8				
OMESTAB9	OMESB3020 (PR)		OMESB3012 (PR)	
		OMESB3016 (PR)	OMESB3019 (EA)	OMESB3021 (PR)

PANHARD RODS	D BUSH	EYE BUSH	UNIT	LINK	LINK BUSH
PANRJK002	N/A	OMESB3015 (2pk)		N/A	N/A
PANRJK003	N/A	OMESB3015 (2pk)		N/A	N/A
PANR004	N/A	OMESB0054	2 EYELETS	N/A	N/A
PAN3097A	N/A	OMESB0054	2 EYELETS	N/A	N/A
PANR005	N/A	OMESB0054	2 EYELETS	N/A	N/A
PANR028X	N/A	OME3098 x 1 OMESB0054 x 1	1 SPHERICAL 1 EYELET	N/A	N/A
PANR029X	N/A	OME3098 x 1 OMESB0054 x 1	1 SPHERICAL 1 EYELET	N/A	N/A
PANR007	N/A	OMESB0046	2 EYELETS	N/A	N/A
PANR008	N/A	OMESB0053	2 EYELETS	N/A	N/A
PAN3050	N/A	OMESB0046	1 EYELET	N/A	N/A

CONTROL ARMS	OME P/NO.	UNIT
LCAJKFR	OMESB3024	SINGLE
LCAJKRR	OMESB3024	SINGLE
LTA3043	OMESB3029	PAIR
LTA3044	OMESB3028	PAIR
UCAJKFR	OMESB3025	SINGLE
UCAJKRR	OMESB3026	SINGLE
UTA3036	OMESB3027	PAIR
UTAA106	OMESB3027	PAIR

1. When remaining stock of OMESTAB2 is exhausted, no further product will be available.

DIAGRAM REFERENCE FOR SUSPENSION BUSH KITS

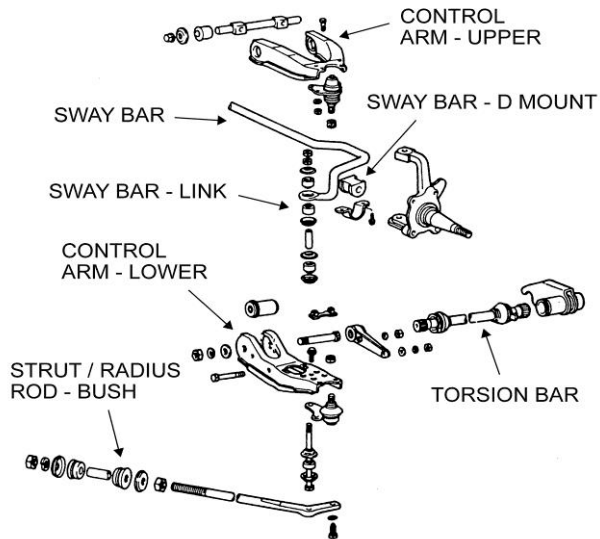

Diagram 1.

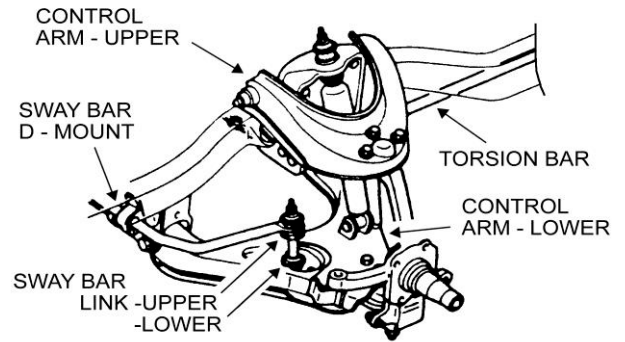

Diagram 2.

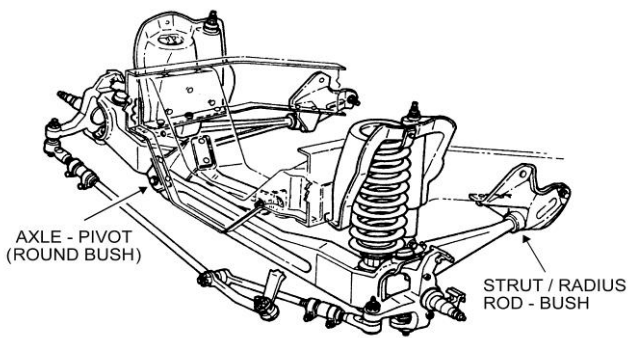

Diagram 3.

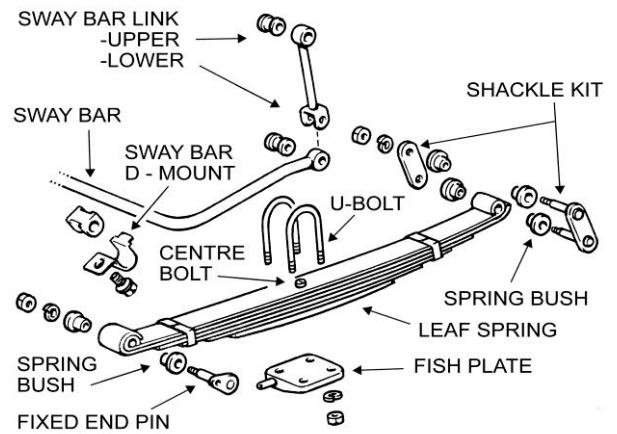

Diagram 4.

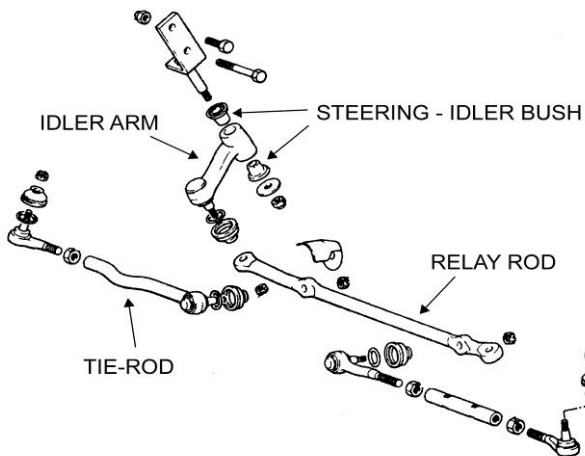

Diagram 5.

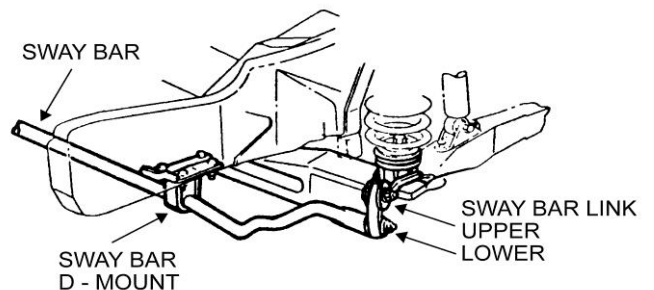

Diagram 6.

DIAGRAM REFERENCE FOR SUSPENSION BUSH KITS

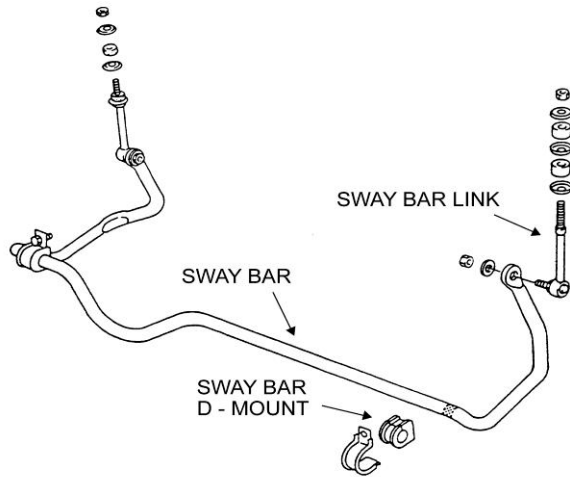

Diagram 7.

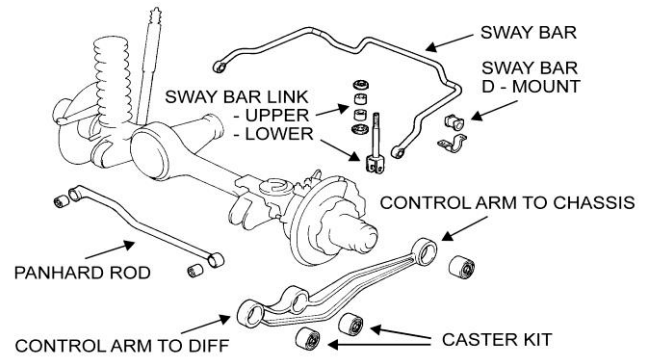

Diagram 8.

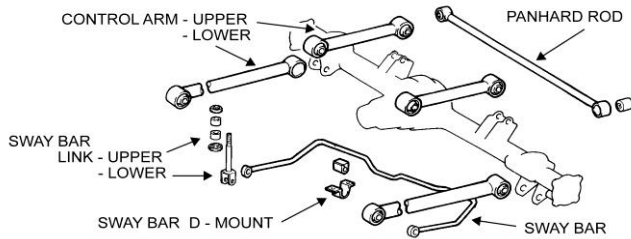

Diagram 9.

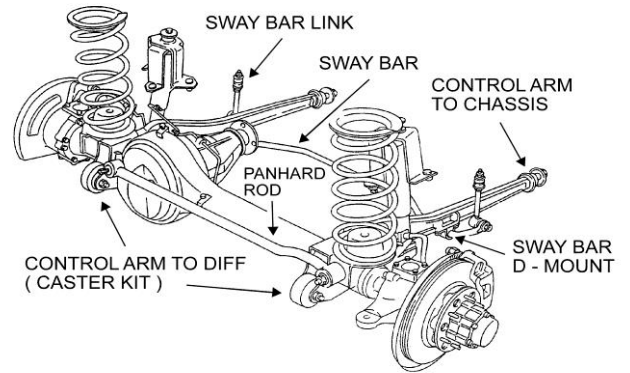

Diagram 10.

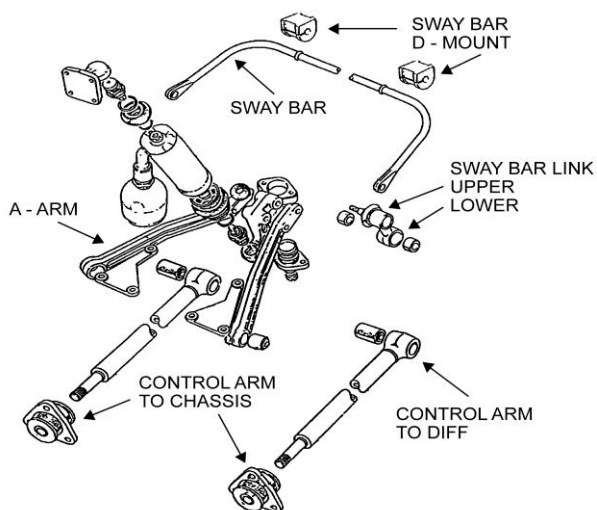

Diagram 11.

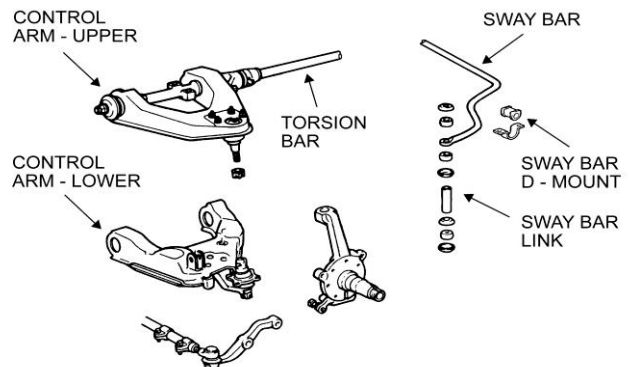

Diagram 12.

APPLICATIONS - SPECIFICATIONS - BUSH KITS

NUMERICAL SPRING & SHOCK / STRUT BUSH

Kit No.	Component Description	Qty	To Fit
OMESB1	spring bush PT260	6	Toyota 35mm spring eye, 18mm pin OE & OME Series F/H/B, J/ZJ: 75, 74, 73, 70, 60, 47, 45, 42, 40 Nissan GQ Patrol leaf spring models OME only
OMESB2	spring bush PT280 spring bush PT281	2 2	Nissan MQ Patrol all models - rear OE spring
OMESB3	spring bush PT282	2	Nissan MQ Patrol round headlight models-front OE spring eye
¹ OMESB4	spring bush PT230 spring bush PT229	4 2	OBSOLETE
OMESB5	spring bush PT240 spring bush PT231	2 4	Toyota HiLux all models (except IFS front)
OMESB6	spring bush PT231	6	Toyota HiLux all models (except SR5 & extra cab rear)
¹ OMESB7	OBSOLETE	6	Toyota FJ55 all models front & rear, 45 Series rear only OE springs 30mm eye
OMESB8	spring bush PT290 spring bush PT291 spring bush PT292	2 2 2	Mitsubishi Pajero leaf spring models & L200 models
¹ OMEB9	shock bush SP1178 / 19	4	Small eye bush with 19mm bore
OMEB10	shock bush SP056 (cotton reel type)	2	Small eye shock mount
OMEB11	shock bush OME066 / 16	4	Converts large eye 19mm bore to a 16mm bore
¹ OMEB12	shock bush kit	4	Pin 12 x 60 replacement bush
OMEB13	shock bush SP091	4	Pin 10 x 60 replacement bush
OMEB14	shock bush OME1178 / 16	4	Small eye with 16mm bore
OMEB15	shock bush OME066 / 19	4	Large eye with 19mm bore
OMESB16	spring bush PT270	6	40mm spring eye for Toyota 75 series rear springs
OMEB17	shock bush OME066 / 22 sleeve B17S 22 x 16 x 33	2 2	Large eye tapered bush with sleeve
¹ OMEB18	OBSOLETE	2	Converts small eye bush to suit 19mm bore with sleeves
OMESB19	spring bush PT301 spring bush PT302 sleeve B19S 16 x 13 x 65	2 4 1	Suzuki Sierra all models except LJ50 front & rear springs
OMESB20	spring bush PT229	6	Toyota LandCruiser 40 series 25mm OE spring front & rear. Toyota 45 series OE front spring only 25mm eye.
OMESB25	spring bush PT301 spring bush PT302 spring bush PT303 sleeve 16 x 13 x 65	2 2 2 1	Suzuki LJ50 front & rear
OMEB27	sleeve 16 x 13.2 x 33	2	N41 & N81 being converted for fitment to CJ Jeep and Cherokee wagon 83 on front bottom mount. Mahindra front & rear bottom mount.
OMESB28	spring bush PT284	2	Nissan MQ Patrol early model (round headlights) - front spring, front eye (to be fitted with OMESB29)
OMESB29	spring bush PT285 & sleeve	1	Nissan MQ Patrol all models - front spring, rear eye (to be fitted with OMESB28)
OMESB30	spring bush PT261 spring bush PT229	4 2	Toyota LandCruiser 45/47 Series front spring with 35mm spring eye and hanger bracket with 15mm pin hole
OMESB31	spring bush PT283	2	Nissan MQ Patrol late model (square headlights) - front spring, front eye (to be fitted with OMESB29)
OMEB36	shock bush OME066 / 19	2	large eye 19mm bore
OMESB38	spring bush PT292 spring bush PT291 spring bush PT305 sleeve 19 x 14.2 x 81	2 2 2 1	All Triton to 1997 and L200 - rear - suits OME springs only
OMEB40	shock bush OME 066-19MGQ	2	N101, ¹ N22F & N29 Patrol GQ lower mount - rear shock
OMEB42	shock bush 305IY	8	pin 14 x 70 replacement

1. When remaining stock is exhausted no further product will be available.

cont.

APPLICATIONS - SPECIFICATIONS - BUSH KITS

NUMERICAL SPRING & SHOCK / STRUT BUSH

Kit No.	Component Description	Qty	To Fit
OMESB43	spring bush PT304 spring bush PT309 spring bush PT231 sleeve 19 x 14.1 x 68	2 2 2 1	Toyota HiLux IFS extra cab & SR5 dual cab models being fitted with OME18 ¹ series spring
OMESB57	spring bush PT306 spring bush PT307 sleeve 19 x 15 x 73	4 2 1	Jeep Wrangler - front & rear to suit OE shackles
OMESB64	spring bush PT270 spring bush PT260	4 2	Nissan Patrol GQ leaf spring cab chassis OME spring - rear
¹ OMESB75	spring bush LA118 spring bush LA119 sleeve 19 x 14.3 x 91 sleeve 19 x 15 x 70	2 4 1 2	Land Rover Series III 88" & 109" spring & shackle bushes OE replacement - front
¹ OMESB76	spring bush kit	6 3	Land Rover series III 88" & 109" spring & shackle bushes OE replacement - rear
¹ OMEB77	shock bush kit	4	Land Rover Series III 88" & 109" lower shock bush - rear
¹ OMEB78	steering damper bush kit	4	Pin 10 x 60mm steering stabiliser mount
OMESB79	spring bush PT308 spring bush PT231A	4 2	LandCruiser F/HJ45, 47 LWB models - OME spring
OMESB80	spring bush PT304 spring bush PT231 sleeve 19 x 14 x 68	2 4 1	Holden / Isuzu Rodeo 1 tonne rear spring to suit OE & OME springs
OMESB81	spring bush PT310 spring bush PT311 sleeve 22 x 18 x 70	4 2 1	Nissan Navara 1 tonne rear spring to suit OE & OME springs
OMESB82	spring bush PT281 spring bush PT314 spring bush PT315 sleeve 22 x 17 x 68	2 2 2 1	Mazda / Ford 1 Tonne 4x4 1987 on rear spring OME only
OMESB83	spring bush PT291 spring bush PT292 spring bush PT316 sleeve 22 x 16 x 80	2 2 2 1	Mitsubishi Challenger / Montero rear spring to suit OME19 ¹ only
OMESB84	spring bush PT317 spring bush PT318 sleeve 20 x 14 x 86	2 4 2	Toyota LandCruiser 79 Series cab chassis & utility model only suit OME springs only
OMESB85	spring bush PT270 spring bush PT317	4 2	Toyota LandCruiser 78 & 79 Series must be used with OME springs & greasable shackle kit only
OMESB86	spring bush PT327 spring bush PT318 spring bush PT319 sleeve 20 x 14 x 86	2 2 2 1	Toyota LandCruiser 76 & 78 Series Rear suit OME springs with OE shackles.
OMESB87	spring bush PT307 spring bush PT320 spring bush PT321 sleeve 19 x 15 x 73	2 2 2 1	Jeep YJ Wrangler front and rear Use only with greasable shackle OMEGS11
OMESB88	spring bush PT322 spring bush PT323	2 2	Toyota Tacoma rear shackle bushes only Use with OME springs & OMEGS12 greasable shackles.
OMESB89	spring bush PT322 spring bush PT323 sleeve 18 x 14 x 69	2 2 1	Toyota Tacoma rear shackle bushes for OEM shackles
OMESB90	spring bush PT231 spring bush PT282	4 2	Holden/Isuzu Jackaroo Trooper 1982-92 rear OME spring
OMESB91	spring bush PT310 spring bush PT311 spring bush PT326	2 2 2	Nissan Navara D22 model - rear spring to suit OE & OME springs

1. When remaining stock is exhausted no further product will be available.

cont.

APPLICATIONS - SPECIFICATIONS - BUSH KITS

NUMERICAL SPRING & SHOCK / STRUT BUSH

Kit No.	Component Description	Qty	To Fit
OMESB91 (cont.)	sleeve 22 x 18 x 70	1	Nissan Navara D22 model - rear spring to suit OE & OME springs
OMESB93	spring bush PT260 spring bush PT317	4 2	Toyota LandCruiser HZJ71 & HZJ74
¹ OMESB95	spring bush PT326 spring bush PT331	2 2	Nissan D40 Navara suits OE shackle kit only
¹ OMESB96	spring bush PT324 spring bush PT325	2 2	Nissan D40 Navara suits OME greasable shackle kit only
OMESB97	spring bush PT281 spring bush PT314 spring bush PT333 sleeve 19 x 14 x 72	2 2 2 1	Mazda BT50 / Ford Ranger 2006 on
OMESB98	spring bush PT328 spring bush PT329 spring bush PT333 sleeve 19 x 14 x 72	2 2 2 1	Toyota HiLux 2005 on to suit OE & OME springs. Holden Colorado 12 on / Isuzu DMAX 12 on suits OME Greasable Shackle, OMEGS14.
OMESB99	spring bush PT282 spring bush PT326 spring bush PT331 sleeve 18 x 14 x 69	2 2 2 1	Nissan Navara D40 suits original shackle kit only.
OMESB100	spring bush PT282 spring bush PT324 spring bush PT325 sleeve 18 x 14 x 69	2 2 2 1	Nissan Navara D40 suits OME greasable shackle kit: OMEGS15
OMESB101	spring bush PT319 spring bush PT327	4 2	Toyota LandCruiser 79 Series suits original shackle & pin from 07/2009 on
OMESB102	spring bush PT310 spring bush PT333 spring bush PT336 sleeve 19 x 14 x 72	2 2 2 1	Ford Ranger PX 2011 on / Mazda BT-50 2011 on suits OE shackle
OMESB103	spring bush PT335 spring bush PT333 spring bush PT281 sleeve 19 x 14 x 72	2 2 2 1	Ford Ranger PX 2011 on / Mazda BT-50 2011 on suits OME greasable shackle kit OMEGS20
OMESB104	bush leaf spring VW-007 bush leaf spring VW-008	1 1	Volkswagen Amarok
OMESB105	spring bush PT324 spring bush PT311 sleeve 22 x 18 x 70	4 2 1	Nissan Navara D22 suits OME greasable shackle
OMESB106	spring bush PT317 spring bush PT282 spring bush PT333 sleeve 19 x 14 x 72	2 2 2 1	Toyota Tundra suits OME greasable shackle
OMESB107	spring bush PT333 spring bush PT337 spring bush PT338 sleeve 19 x 14 x 72	2 2 2 1	Holden Colorado / Isuzu DMAX suits OE shackle
OMESB108	spring bush PT333 sleeve 19 x 14 x 72	4 2	Toyota Tacoma 2016 On / Tacoma V6 05 to 15 suits OE shackle
OMESB109	spring bush PT341 sleeve 26 x 20 x 89 sleeve 26 x 16 x 89	4 1 1	Ford F250, F350 2011 To 2017 F250, F350 2008 To 2010
OMESB113	spring bush PT345 spring bush PT291 spring bush PT344 sleeve 19 x 14 x 78	2 2 2 1	Mitsubishi Triton MQ
OMESB114	spring bush PT346 spring bush PT282 sleeve 18 x 14 x 69	4 2 1	Nissan Navara NP300 suits OE shackles

1. When remaining stock is exhausted no further product will be available.

cont.

APPLICATIONS - SPECIFICATIONS - BUSH KITS

NUMERICAL SPRING & SHOCK / STRUT BUSH

Kit No.	Component Description	Qty	To Fit
OMESB115	spring bush PT324	4	Nissan Navara NP300 suits OME greasable shackle
	spring bush PT282	2	
	Sleeve 18 x 14 x 69	1	
OME3101	upper bush 3101A	1	Mitsubishi Pajero 2000 on
	lower bush 3010B	1	
	crush tube F0043	1	
OME3121	upper bush 67257	1	Mitsubishi Triton ML / Triton MN / Challenger 2010 on
	lower bush 67258	1	
	washer 5w327	2	
	F1528 16 x 10.2 x 36	1	
OME3125	upper bush 68509A-2	1	Toyota Landcruiser 200 Series
	lower bush 68510-2	1	
	washer 5w327	2	
OME3133	upper bush 68351	1	Toyota HiLux 05 on / Prado 150 / Prado 120 / FJ Cruiser / Fortuner / 4 Runner / Tacoma
	lower bush 68352	1	
	washer 5w327	2	
OME3134	upper bush 68201	1	Holden Trailblazer 2017 on / Colorado 7 2013 to 2016 /Colorado 2012 on / Isuzu DMAX 2012 on / MU-X2013 on
	lower bush 68202	1	
	washer 5w327	2	
OME3135	upper bush 68168	1	Ford Ranger PX 2011 on / Mazda BT-50 2011 on
	lower bush 68169	1	
	washer 5w327	2	
	crush tube F1281	1	
OME3139	upper bush 67496	1	Nissan Navara D40 2005 on, Pathfinder R51 2005 to 2014, Xterra 2005 on Suzuki Equator
	lower bush 67496	1	
	washer 5w327	2	
	crush tube F0055	1	

SPECIFICATIONS - BUSH KITS

OLD MAN EMU POLYURETHANE SPRING BUSH DIMENSIONS

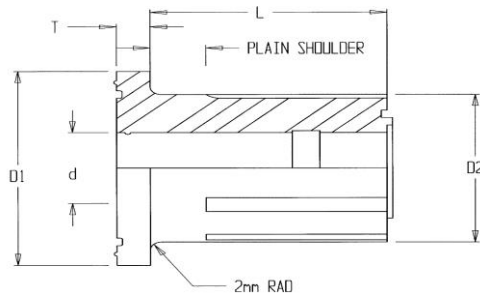

Dimensions						
Part No.	D1	D2	d	T	L	Number of Splines
PT229	32.0	24.9	15.0	4.5	35.0	9
PT230	32.0	24.9	15.0	3.0	35.0	9
PT231	36.0	30.0	18.0	3.6	30.0	9
PT240	36.0	30.0	18.0	4.0	48.0	9
PT260	45.0	35.0	18.0	5.5	35.0	11
PT261	45.0	35.0	15.0	4.0	35.0	9
PT270	50.0	40.0	18.0	5.4	35.0	13
PT280	44.0	32.7	18.0	5.2	43.0	11
PT281	44.0	32.7	18.0	4.5	30.0	11
PT282	52.0	40.0	18.0	4.4	30.0	13
PT283	44.0	32.7	18.0	5.8	28.5	13
PT285	32.7	None	22.0	None	60.0	0
PT290	45.0	31.5	18.0	4.4	35.0	11
PT291	40.0	28.0	16.0	5.0	44.0	9
PT292	40.0	27.5	16.0	4.2	34.0	9
PT301	50.0	40.0	16.0	6.9	25.0	13
PT302	40.0	30.0	13.0	4.4	25.0	9
PT304	52.0	40.0	19.0	4.0	30.0	9
PT305	43.0	31.5	19.0	5.5	35.0	0
PT306	44.0	31.4	18.1	6.0	30.0	9
PT307	50.0	37.6	18.1	6.0	30.0	0
PT309	40.0	30.0	18.0	4.0	40.5	0
PT310	42.0	32.6	20.1	4.0	30.0	0
PT311	52.0	40.0	22.2	4.5	30.0	9
PT314	44.0	32.0	18.0	4.5	40.0	0
PT315	40.0	32.7	22.2	4.0	30.0	9
PT316	43.0	31.5	22.2	5.0	35.0	0
PT317	52.0	39.8	18.0	6.0	43.5	9
PT318	52.0	39.8	20.0	8.0	35.5	9
PT319	52.0	40.0	18.0	9.5	35.5	9
PT320	44.0	31.8	18.0	6.5	31.5	9
PT321	44.0	31.8	18.0	4.3	32.7	9
PT322	40.0	32.0	18.0	4.0	45.5	9
PT323	40.0	30.0	18.0	4.5	35.5	9
PT324	42.0	33.0	19.0	4.0	30.0	9
PT325	42.0	33.0	19.0	4.0	44.5	9
PT326	42.0	33.0	20.1	4.0	30.0	9
PT327	52.0	39.8	18.0	8.0	42.5	9
PT328	39.0	30.0	19.0	4.0	30.0	9
PT329	39.0	30.0	19.0	4.0	44.5	9
PT330	54.0	39.5	19.0	6.0	30.0	9
PT331	42.0	33.0	20.1	4.0	44.5	9
PT333	52.0	39.9	19.0	6.0	30.0	9
PT335	45.0	32.0	18.0	4.5	49.0	9
PT336	42.0	32.0	20.0	4.0	49.0	9
PT337	38.0	30.0	18.0	5.0	30.0	9
PT338	38.0	30.0	18.0	5.0	45.0	9
PT341	50.0	42.0	26.0	6.0	38.0	9
PT344	52.0	39.9	19.0	9.5	29.0	9

SPECIFICATIONS - FITTING KITS

SUSPENSION FITTING KITS

Part No.	Contains	Vehicle	Position	Refer to:
FK01	16 x Flat Washer	Toyota LC 60 Series	Front	Manual Sec. 4 GFI - Front suspension installation
FK03	2 x Saddle Correction Plate	Toyota HiLux Petrol	Front	Manual Sec. 4 GFI - Front suspension installation
FK0411	4 x Retainer Spacer 11mm	Toyota LC 60 Series	Rear	Manual Sec. 4 GFI
FK0418	4 x Retainer Spacer 18mm	Toyota LC 60 Series	Rear	Manual Sec. 4 GFI
FK0422	4 x Retainer Spacer 22mm	Toyota LC 60 Series	Rear	Manual Sec. 4 GFI - Rear suspension installation
FK047	4 x Retainer Spacer 7mm	Toyota LC 60 Series	Rear	Manual Sec. 4 GFI - Rear suspension installation
FK06	2 x Stabiliser Bar Packer 3mm	Suzuki	Front	Manual Sec. 4 GFI - Front suspension installation
FK08	2 x Anti-Inversion Plate	Toyota LC 60, 75 Series All 40 & 70 Series, Nissan GQ Patrol, Ford Maverick ute & c/c	Front & Rear	Manual Sec. 8 Technical - Shackle Modification
FK09	2 x Anti-Inversion Plate	Toyota HiLux all models	Rear	Manual Sec. 8 Technical - Shackle Modification
FK10	2 x Short Gussett Plate 2 x Long Gussett Plate	Toyota HiLux all models	Front	Manual Sec. 8 Technical - HiLux Front Springs
FK13	2 x Anti-Inversion Side Plate	Toyota HiLux all models	Rear	Manual Sec. 4 GFI
FK14	2 x Anti-Inversion Plate	Isuzu 1 Tonne P/Up	Rear	Fitting instructions supplied with kit
FK15	2 x Anti-Inversion Side Plate	HiLux 1997 to 2004	Rear	Fitting instructions supplied with kit
FK16	2 x 20mm Bump Stop Spacer	Jeep Wrangler TJ	Rear	Fitting instructions supplied with kit
FK18	2 x Bracket 3 x Bolt 3 x Washer 3 x Nut	Nissan GU Patrol	Rear Sway Bar	Fitting instructions supplied with kit
FK19	4 x Spacer Plate 4 x 35mm Bolt 4 x Spring Washer	LandCruiser 70S DC, 76S Wagon, 78S & 79S SC Models	Front Sway Bar	Fitting instructions supplied with kit
¹ FK20	6 x Spacer Plate 8 x Bolt M8 x 1.25 x 35mm 8 x Flat Washer	Land Rover Discovery 1999 on Models	Front Cross Member	Fitting instructions supplied with kit
FK21	1 x Bracket 2 x Bolt M8 2 x Flat Washer 2 x Hex Nut	Toyota Tacoma V6 & 4 cylinder 1998 to 2004	Rear Exhaust Bracket	
FK22	2 x Shock Tower Support 2 x Captive Nut 4 x Bolt M10 x 1.5 x 30mm 4 x Flat Washer 4 x Spring Washer	Mazda / Ford 1 tonne pickup	Front	Fitting instructions
FK23	1 x Strut Adaptor	Toyota RAV 4 1998 to 2000	Front	Fitting instructions
FK24	2 x Bracket 6 x Bolt 11 x Flat Washer 6 x Nut Nyloc	Nissan Y61 Patrol with stabiliser bar release	Rear Sway Bar	Fitting instructions
FK25	2 x Spacer Block 4 x Bolt 4 x Flat Washer 4 x Spring Washer	Nissan Y61 Patrol Oil Pan Kit	Front	Fitting instructions
FK26	2 x Side Plate	Isuzu DMAX & Holden Colorado RC 08 to 11 Holden Rodeo 03 to 08	Rear	Fitting instructions supplied with kit
FK27	2 x Support Bracket	Toyota LandCruiser 100 Series IFS	Torsion Bar Locating Bracket	Fitting instructions supplied with kit
FK28	2 x Spacer 2 x Stud	Suzuki XL7	Front	Fitting instructions supplied with kit
FK29	2 x Spacer 2 x Bolt M10 x 1.25 x 35mm 2 x Flat Washer M10 x 25mm 2 x Spring Washer M10 x 1/8	Toyota Fortuner 2015 on Toyota Tacoma 2016 on Toyota Tacoma V6 2005 to 2015	Rear Drive Shaft	Fitting Instructions

1. When remaining stock is exhausted no further product will be available.

cont.

SPECIFICATIONS - FITTING KITS

SUSPENSION FITTING KITS

Part No.	Contains	Vehicle	Position	Refer to:
FK30	2 x Anti-Inversion Bracket	Mitsubishi	Rear	Fitting Instructions
FK31	1 x Bracket 6 x Bolt 4 x Nut x M10 2 x Nut x M10 Caged 3.3 6 x Spring Washer 10 x Flat Washer	Ford F250, F350 1999 to 2004 Dual Cab Models	Rear	Fitting instructions
FK32	1 x 3199908 Bracket 1 x 3199909 Kit 2 x Bolt M8 x 1.25 x 20 2 x Hex Nyloc Nut 4 x Flat Washer	Toyota Tundra 2007 on	Front	Fitting instructions
FK33	Spring Bush Installation Tool	Volkswagen VK Amarok	Front	Fitting Instructions
FK34	2 x Bracket	Toyota LandCruiser 78 Series	Rear Sway Bar Mounts	Fitting Instructions
FK35	1 x Spacer 2 x Bolt 2 x Nut 2 x Washer	Ford F250, F350 1999 to 2004 Xtra Cab	Rear	Fitting Instructions
FK36	4 x Bracket 8 x Bolt M8 x 1.25 x 20 8 x Nut M8 x 1.25 16 x Washer	Ford F350 2005 to 2008	Front	Fitting instructions supplied with kit
FK37	1 x Bracket 2 x Bump Stop Spacer 1 x Extension Plate 4 x Packer 2 x Bolt M14 x 1.5 2 x Nut M14 x 1.5 8 x Washer 2 x Bolt M12 x 1.25 2 x Nut M12 x 1.25 4 x Bolt M8 x 1.25 x 20 4 x Flanged Nuts M8 x 1.25	Jeep Wrangler JK LHD	Rear	Fitting instructions supplied with kit
FK38	2 x Anti-Inversion Plate	Toyota LandCruiser 76 Series	Rear	Fitting instructions supplied with kit
FK39	1 x Bracket 2 x Bump Stop Spacer 1 x Extension Plate 4 x Packer 2 x Bolt M14 x 1.5 2 x Nut M14 x 1.5 8 x Washer 2 x Bolt M12 x 1.25 2 x Nut M12 x 1.25 4 x Bolt M8 x 1.25 x 20 4 x Flanged Nut M8 x 1.25	Jeep Wrangler JK RHD	Rear	Fitting instructions supplied with kit
FK40	4 x Bump Stop Spacer 2 x Bolt M10 x 1.5 x 75 4 x Bolt M8 x 1.25 x 70 4 x Washer 2 x Flanged Nut 4 x Nut Nyloc	Jeep Wrangler JK	Front & Rear	Fitting instructions supplied with kit
FK41	2 x Bracket Assembly Bump Stop Spacer	Nissan GU Patrol - Leaf Sprung	Rear	Fitting instructions supplied with kit
FK42	2 x Sway Bar Packer 4 x Bolt M10 x 1.25 x 35 4 x Flat Washer M10 4 x Spring Washer M10	Nissan Xterra 2005 on	Rear	Fitting instructions supplied with kit

cont.

SPECIFICATIONS - FITTING KITS

SUSPENSION FITTING KITS

Part No.	Contains	Vehicle	Position	Refer to:
FK43	4 x Backing Plate 4 x Backing Plate Wear Clip 4 x Bolt M8 x 1.25 4 x Nyloc Hex Lock Nut 4 x Tube Spacer	Nissan Y61 Patrol - Leaf Sprung	Rear	Fitting instructions supplied with kit
¹ FK44	2 x Saddle Bracket 2 x HD Bar Bracket (1 x RH, 1 x LH) 10 x Flat Washer M8 x 17 10 x Bolt M8 x 1.25 x 25 10 x M8 Spring Washer	Toyota LandCruiser 76/78/79 Series	Rear	Fitting instructions supplied with kit
¹ FK45	2 x Axle Mount Bracket (1 x RH, 1 x LH) 1 x OMEU74 U Bolt 1 x OMEU75 U Bolt 2 x Saddle Bracket 1 x Brake Line Bracket 2 x Dropper Bracket (1 x RH, 1 x LH) 3 x Spacer Wing Mount 1 x Grub Screw M10 x 1.25 x 10 1 x M10 Flat Washer 1 x Nut Flange M10 x 1.25 9 x Flat Washer M8 x 17 9 x BZ Bolt M8 x 1.25 x 25 9 x Spring Washer M8 x 3/32 x 3/32	Toyota LandCruiser 76/78/79 Series	Rear	Fitting instructions supplied with kit
FK46	2 x Front Brake Line Bracket (1 x RH, 1 x LH) 2 x Rear Brake Line Bracket (1 x RH, 1 x LH) 1 x Hand Brake Bracket 6 x Bolt M6 x 1.0 x 20 8.8BZ 10 x Washer M6 x 20 16G 5 x Nyloc Nut M6 x 1 2 x Spring Washer M6 x 2.5 x 1.6 2 x Caged Nut M6 1.7 - 2.5	Jeep Wrangler JK	Front Rear	
FK47	1 x Track Bar Bracket 1 x Track Bracket Spacer 2 x U Bolt 1 x Bolt M14 x 1.5PX80 2 x Spacing Washer M14 x 23.5 x 5mm 1 x Nyloc Nut M14 x 1.5	Jeep Wrangler JK LHD	Rear	
FK47RHD	1 x Track Bar Bracket 1 x Track Bar Bracket Spacer 2 x U Bolt 1 x Bolt M14 x 1.5PX80 2 x Spacing Washer M14 x 23.5 x 5mm 1 x Nyloc Nut M14 x 1.5	Jeep Wrangler JK RHD	Rear	
FK48	2 x Front Sway Bar Link 2 x Rear Sway Bar Link 2 x Dis-connect Pin 2 x Park Pin 2 x Sway Bar Bracket (1 x RH, 1 x LH) 2 x R-clip 3.0 TZP 2 x Bolt 7/16 x 3 1/2 GR5 4 x Flat Washer 7/16 2 x Spring Washer 7/16 x 5/32 x 3/32 2 x Nut 7/16 2 x Nyloc Nut M12 2 x Nyloc Nut M10 x 1.25 2 x Flat Washer 1/2 x 1 1/8 x 3mm 2 x Flat Washer M10 x 20.6 x 2mm Fitting Grease	Jeep Wrangler JK	Front Rear	
FK49	8 x Driveline Packer 3 x Crossmember Spacer	Jeep Wrangler JK	Front Rear	

1. When remaining stock is exhausted no further product will be available.

SPECIFICATIONS - FITTING KITS

SUSPENSION FITTING KITS

Part No.	Contains	Vehicle	Position	Refer to:
FK49 (cont.)	2 x Flange Bolt M14 x 1.5 x 110 GR10.9 2 x Flange Bolt M14 x 1.5 x 10 GR10.9 4 x Flange Nut Conelock M14 x 1.5 Class 10 3 x Bolt M12 x 1.5 x 50mm 8.8 3 x Flat Washer 1/2 x 1 1/8 x 3mm 3 x Spring Washer 1/2 x 3/16 x 1/8 2 x Cable Tie 4.8 x 200mm	Jeep Wrangler JK	Front Rear	
FK50	1 x Stabiliser Plate 1 x Stabiliser Spacer 1 x Bolt M10 x 1.25 x 25 8.8 1 x Flat Washer M10 x 20.6 x 2mm 1 x Flange Nut M10 x 1.25 FP	Jeep Wrangler JK	Front	Fitting instructions supplied with kit
FK51	2 x Brake Proportioning Bracket 2 x Flange Nut M8 x 1.25 BZ 2 x Flat Washer M8 x 17 x 1.2 2 x Bolt M8 x 1.25PX20	Toyota LandCruiser 70S DC / 76S Wagon / 78S / 79S SC	Rear	Fitting instructions supplied with kit
FK53	4 x Driveline Packer 2 x Flange Bolt M14 x 1.5 x 110 GR10.9 2 x Flange Nut Conelock M14 x 1.5 Class 10	Jeep Wrangler JK	Front	Fitting instructions supplied with kit
FK56	1 x Packer Strut 5mm	Ford Everest 15 on / PXII 15 on / PX 11 to 15 Mazda BT-50 11 on	Front	Fitting instructions supplied with kit
FK57	12 x Flat Washer M14 x 25 x 4 2 x Spring Washer M14 x 4mm x 3mm 2 x Female Bolt M10 x 25 x 1.5 8.8	Ford Ranger 2011 on Mazda BT-50 2011 on	Centre Bearing	Fitting instructions supplied with kit
FK58	2 x Brake Proportioning Bracket 2 x Flange Nut M8 x 1.25 BZ 2 x Flat Washer M8 x 17 x 1.2 2 x Bolt M8 x 1.25PX20 4.6 2 x spring Washer M8 x 3/32 x 3/32	Toyota LandCruiser 70S DC / 76S Wagon / 78S / 79S SC	Rear	Fitting instructions supplied with kit
FK59	1 x Brake Prop Bracket 1 x Bolt M8 x 1.25PX20 8.8 1 x Hex Lock M8 x 1.25 2 x Flat Washer M8 x 17 x 1.6 1 x Spring Washer M8 x 3/32 x 3/32	Toyota HiLux 05 to 15	Rear	Fitting instructions supplied with kit
FK61	1 x Rear Panhard Bracket 1 x Spacer Bracket 2 x U Bolt 1 x M14 x 1.5 x 80 Bolt 1 x M14 x 1.5 Nyloc Nut 2 x M14 x 23.5 x 5mm Spacing Washer 2 x Bump Spacer Bracket 4 x M8 x 1.25 x 20 Hex Bolt 4 x M8 x 1.25 Nut Flange 4 x M8 x 17 x 1.6 Flat Washer	Jeep Wrangler JK 2" RHD	Rear	Fitting instructions supplied with kit
FK62	2 x Front Bracket 2 x Rear Bracket 4 x M8 x 1.25 Bolt 8 x M8 x 17 Flat Washer 8 x M8 Nut Flange 4 x M8 x 1.25 x 50 Bolt	Land Rover Defender	Front Rear	Fitting instructions supplied with kit
FK63	2 x Front Bracket 2 x Rear Bracket 16 x M8 x 1.25 x 25 Bolt 16 x M8 x 17 Flat Washer 16 x M8 Nut Flange 8 x M10 Screw Hex 8 x M10 Flat Washer 8 x M10 Nut Flange	Land Rover Defender	Front Rear	Fitting instructions supplied with kit

cont.

SPECIFICATIONS - FITTING KITS

SUSPENSION FITTING KITS

Part No.	Contains	Vehicle	Position	Refer to:
FK64	1 x LH Bracket 1 x RH Bracket	Land Rover Defender	Rear	Fitting instructions supplied with kit
FK65	1 x LH Bracket 1 x RH Bracket 2 x M8 Caged Nut 2 x Bolt M8 x 16 x 1.25 2 x Flat Washer M8 x 17 2 x Spring Washer M8	Toyota LandCruiser 70 Series	Front Brakes	Fitting instructions supplied with kit
FK66	2 x Bracket Leaf Cable 2 x Hex HD Bolt M8 x 16 x 1.25 2 x Hex Lock Nut Nyloc M8 x 1.25 4 x Flat Washer M8 x 17 x 1.6 ZP	Isuzu DMAX CC & LSM Models	Rear	Fitting instructions supplied with kit
FK68	2 x Front Sway Bar Link 2 x Dis-Connect Pin 2 x Park Pin 1 x RH Sway Bar Bracket 1 x Sway Bar Bracket 2 x R-Clip 3.0 Tzp 2 x Bolt 7/16 x 3 1/2 GR5 4 x Flat Washer 7/16 2 x Spring Washer 7/16 x 5/32 x 3/32 2 x Nut 7/16 2 x Nut Nyloc M12 2 x Nut Nyloc M10 x 1.25 2 x Flat Washer 1/2 x 1 1/8 x 3mm 2 x Flat Washer M10 x 20.6 x 2mm Fitting Grease	Jeep Wrangler JK	Front	
FK69	1 x Bracket Panhard Superduty	Ford F250/F350 08 to 17	Front	Fitting instructions supplied with kit
FK70	1 x Bracket RAD ARM GEN3 Superduty R 1 x Bracket RAD ARM GEN3 Superduty L 4 x Bolt Hex M18 2.5 x 130 GR10.9 4 x Nut Nyloc M18 2.5 GR10.9 8 x Washer Flat 3/4 Zinc 2 x Bolt M12 x 1.75 x 35MMZP 2 x M12 1.75 Nyloc 2 x M12 Spring Washer 4 x M12 Flat Washer	Ford F250, F350 2011 to 2017	Front	Fitting instructions supplied with kit
FK71	1 x Bracket Brakeline Superduty R 1 x Bracket Brakeline Superduty L 2 x Plate ESC Outside Superduty 2 x Plate ESC Inside Superduty 2 x Bracket ESC Top Superduty 4 x Bolt HXHD M6 x 1.0 x 25 GR8.8 BTZP480 4 x Nut Hex Nyloc M6 x 1.0 GR8.8 BTZP480 8 x Washer F M6 x 16 x 1.2 PTZP480 2 x Bolt M8 x 1.25 x 70 CUP SQU BLKZP 2 x Nut Hex Nyloc M8 x 1.25 GR8.8 BTZP480 2 x Nut M10 Caged 1231-B 2 x M10 1.5 x 20 ZP 2 x M10 Spring Washer 2 x M10 Flat Washer	Ford F250, F350 2008 to 2017	Front	Fitting instructions supplied with kit
FK72	2 x Bracket Sway Bar Superduty 4 x Bolt M12 x 1.75 x 35MMZP 4 x M12 x 1.75 Nyloc Nut 4 x Washer Spring 1/2 8 x M12 Flat Washer	Ford F250, F350 2008 to 2017	Front	Fitting instructions supplied with kit
FK73	2 x Spacer Bump Front Superduty 2 x M8 1.25 x 50 GR8.8 2 x M8 Flat Washer 2 x M8 Spring Washer	Ford F250, F350 2008 to 2017	Front	Fitting instructions supplied with kit

cont.

SPECIFICATIONS - FITTING KITS

SUSPENSION FITTING KITS

Part No.	Contains	Vehicle	Position	Refer to:
FK74	1 x Packer Trim 10mm F Superduty	Ford F250/F350 08 to 17	Front	
FK76	2 x Saddle Bracket 2 x HD Bar Bracket (1 x RH, 1 x LH) 10 x Flat Washer M8 x 17 10 x Bolt M8 x 1.25 x 25 10 x M8 Spring Washer	Toyota LandCruiser 70S DC / 76S Wagon / 78S / 79S SC	Rear	Fitting instructions supplied with kit
FK77	2 x Axle Mount Bracket (1 x RH, 1 x LH) 1 x OMEU74 U Bolt 1 x OMEU75 U Bolt 2 x Saddle Bracket 1 x Brake Line Bracket 2 x Dropper Bracket (1 x RH, 1 x LH) 3 x Spacer Wing Mount 1 x Grub Screw M10 x 1.25 x 10 1 x M10 Flat Washer 1 x Nut Flange M10 x 1.25 9 x Flat Washer M8 x 17 9 x BZ Bolt M8 x 1.25 x 25 9 x Spring Washer M8 x 3/32 x 3/32	Toyota LandCruiser 70S DC / 76S Wagon / 78S / 79S SC	Rear	Fitting instructions supplied with kit
FK78	1 x Bracket	Nissan GU Cab Chassis	Rear	Fitting instructions supplied with kit
FK79	1 x Strut Packer	Jeep WK2	Front	
FK80	1 x Bracket RAD ARM GEN3 Superduty R 1 x Bracket RAD ARM GEN3 Superduty L 4 x Bolt Hex M18 2.5 x 130 GR10.9 4 x Nut Nyloc M18 2.5 GR10.9 8 x Washer Flat 3/4 Zinc 2 x Bolt M12 x 1.75 x 35MMZP 2 x M12 1.75 Nyloc 2 x M12 Spring Washer 4 x M12 Flat Washer	Ford F250, F350 2008 to 2010	Front	Fitting instructions supplied with kit
FK81	1 x Caster Plate L 1 x Caster Plate R 4 x M8 x 1.25P x 20 4 x Hex Nut Nylon 8 x M8 Flatwasher 1 x Nylon Nut M18 1 x 3/4 Flat Washer	Ford F250, F350 2008 to 2017	Front	Fitting Instructions
FK82	2 x Brake Line Drop Bkt 2 x M8 x 1.25P x 20 1 x Hex Nut Nylon 3 x Flat Washer M8 x 17 1 x M8 Spring Washer 1 x M8 Caged Nut	Toyota LandCruiser 70S DC / 76S Wagon / 78S / 79S SC	Rear Brake Line	Fitting Instructions
FK83	2 x Bump Spare Plate	Nissan Navara NP300	Rear Leaf Spring	Fitting Instructions
FK84	1 x Plate Packer	Nissan Navara NP300	Front Strut	
FK85	2 x Sway Bar Brackets 1 x Pot Bracket 2 x M12 x 1.75 x 30 Bolt 4 x Washer M12 x 27 x 4mm 2 x M12 x 1.75 Nyloc Nut 1 x M8 x 1.25 x 20 Bolt 1 x Washer M8 x 17 x 1.6m	Nissan Navara NP300	Rear	Fitting Instructions
FK86	1 x Extension Bracket 2 x Bolt M6 x 10 2 x M6 Spring Washer 2 x Washer M6 x 1.6 x 20	Toyota HiLux 2015 on	Rear Spring	Fitting Instructions
FK87	2 x Bolt M8 x 1.25 x 12 HD TZP480 1 x Bracket Colorado Brake Line 1 x Bracket Colorado Brake Line	Holden Colorado	Rear Leaf Spring	Fitting instructions supplied with kit

cont.

SPECIFICATIONS - FITTING KITS

SUSPENSION FITTING KITS

Part No.	Contains	Vehicle	Position	Refer to:
FK87 (cont.)	2 x Nut Hex Lock Nyloc M8 x 1.25 2 x Bolt M8 x 1.25 x 16 Hex HD TZP480 8 x Washer Flat M8 x 20 x 2 Black	Holden Colorado	Rear Leaf Spring	Fitting instructions supplied with kit
FK89	3 x Spacer Cross Member 3 x Bolt M12 x 1.5 x 50mm Class 8.8 ZP 3 x Washer Flat 1/2 x 1, 1/8 x 3mm ZP 3 x Washer Spring 1/2 x 3 / 16 x 1/8 ZP	Jeep Wrangler JK	Cross Member Spacer Kit	Fitting Instructions
FKWTJ01	1 x 45mm Panhard Rod Extended	Jeep Wrangler TJ	Rear	Fitting instructions supplied with kit
FKWTJ02	Mounting Bracket 2 x Spacer Washer 3 x Bolt M12 x 1.25 x 30mm 6 x Flat Washer 3 x Spring Washer 3 x Nut M12 x 1.25	Jeep Wrangler TJ	Rear	
GQGK01	4 x Spacer Plate 8 x Hex. Bolt 8 x Flat Washer 8 x Spring Washer	Nissan GQ Patrol Ford Maverick	Gearbox Cross Member	Manual Sec. 4 GFI Patrol Gearbox Spacer Kit
GQGK02	4 x Spacer Plate 9 x Spacer 12mm 8 x Bolt M12 x 1.25 x 70mm 17 x Spring Washer 17 x Flat Washer 6 x Bolt M8 x 1.25 x 40mm 3 x Bolts M8 x 1.25 x 35mm	Nissan Y61 Patrol SWB	Gearbox	Fitting instructions
JWVGK01	6 x Spacer Plate 6 x Bolt Spacer 6 x 2" Bolt	Jeep Wrangler to 2002	Gearbox	Fitting instructions supplied with kit
JWVGK02	6 x Spacer Plate 6 x Bolt 17 x Flat Washer 17 x Spring Washer	Jeep Wrangler TJ 2003 Manual Models	Gearbox	Fitting instructions
JWVGK03	8 x Spacer Plate 8 x Bolt 8 x Flat Washer 8 x Spring Washer	Jeep Wrangler TJ 2003 Auto Models	Gearbox	Fitting instructions
OMETH001	1 x Bearing Plate 1 x Rubber Isolator 2 x Loose Rubber Bushes 1 x Dome Washer 1 x Cupped Washer 1 x Crush Tube 3 x Mounting Nuts M10 x 1.25 Dirt Shield Included	Mitsubishi Challenger 2010 on Mitsubishi Triton ML Mitsubishi Triton MN Mitsubishi Triton MQ	Front One side only on ML	
OMETH002	1 x Bearing Plate With Bonded Lower Bush 1 x Rubber Isolator 2 x Bonded Rubber Bushes (One On Washer One On Bearing Plate) 1 x Loose Washer 1 x Bonded Washer (One On Rubber Bush) 3 x Mounting Nuts M10 x 1.25	Toyota 4 Runner (USA) 03 on Toyota FJ Cruiser 06 on Toyota Fortuner 04 on Toyota HiLux 05 on Toyota Prado 150 Series Toyota Prado 120 Series Toyota Tacoma 05 on	Front One side only on HiLux 05 On	
OMETH003	1 x Bearing Plate With Bonded Lower Bush 1 x Rubber Isolator 2 x Bonded Rubber Bushes (One On Washer One On Bearing Plate) 1 x Loose Washer 1 x Bonded Washer (One On Rubber Bush) 4 x Mounting Nuts M10 x 1.25	Toyota LandCruiser 200 Series	Front One side only 200 Series	

cont.

SPECIFICATIONS - FITTING KITS

SUSPENSION FITTING KITS

Part No.	Contains	Vehicle	Position	Refer to:
OMETH004	1 x Bearing Plate With Bonded Lower Bush 1 x Rubber Isolator 2 x Bonded Rubber Bushes (One On Washer One On Bearing Plate) 1 x Loose Washer 1 x Bonded Washer (One On Rubber Bush) 3 x Mounting Nuts M10 x 1.50	Holden Trailblazer 2017 on/Colorado 7 2013 to 2016/Colorado 2012 on Isuzu DMAX 2012 on / MU-X 2013 on	Front One side only	
OMETH005	1 x Bearing Plate 1 x Rubber Isolator & Bush Combined 1 x Loose Rubber Bush 2 x Cupped Washers Sized Differently 1 x Crush Tube 3 x Mounting Nuts M10 x 1.50	Nissan Navara D40 2005 on Nissan Pathfinder R51 2005 to 2014	Front One side only D40	
OMETH006	1 x Bearing Plate 1 x Rubber Isolator 2 x Loose Rubber Bushes 2 x Cupped Washers 1 x Crush Tube 3 x Mounting Nuts M12 x 1.75	Ford Ranger 2011 on Mazda BT-50 2011 on	Front One side only One side only	
OMETH007	1 x Bearing Plate 1 x Rubber Isolator 2 x Loose Rubber Bushes 1 x Dome Washer 1 x Cupped Washer 1 x Crush Tube 3 x Mounting Nuts M10 x 1.25	Mitsubishi Pajero NM 2000 on	Front One side only	
XJGK01	4 x 10mm Packer 2 x 6mm Packer 4 x M10 x 1.5 x 50 8.8 Bolt 4 x 3/8 x 3/4 Flat Washer 4 x M10 Spring Washer 1 x 25mm Spacer 1 x M8 x 1.25 x 40 8.8 Bolt 1 x M8 x 17 Flat Washer 1 x M8 Spring Washer	Jeep Cherokee XJ Wagon 1984 on	Gearbox	Fitting instructions supplied with kit

SPECIFICATIONS - LEAF SPRINGS

ADDING AN EXTRA LEAF

Part No.	Required Centre Bolt	To Suit Spring No.
D1XL	UCB3	CS003F & CS004F
D2XL	UCB2	CS004RA/B & CS005RA/B & CS017RA/B
D3XL	UCB8	CS001F & CS002F
D4XL	UCB8	CS001R & CS002R
D5XL	UCB6	CS009R & CS010R
D6XL	UCB6	CS019R & CS020R & CS021R
D7XL	UCB5	CS040R & CS041R
D8XL	UCB4	CS003R
D9XL	UCB17	CS026R & CS027R
D10XL	UCB5	CS042R
D11XL	UCB5	CS010FA/B
D12XL	UCB1	CS011R & CS012R
D13XL	UCB14	¹ CS043R & ¹ CS044R & ¹ CS045R & ¹ CS071R & CS043R-15
D14XL	UCB17 / UCB4	¹ CS013R & ¹ CS014R & ¹ CS015R & ¹ CS066R
D15XL	UCB11	CS016RA/B
D16XL	UCB5	CS006F
D17XL	UCB7	CS008FA/B
D18XL	UCB14	CS030R & CS031R & [*] CS032R
D19XL	UCB16	CS028R & CS029R
D20XL	UCB7	CS012FA/B & CS013FA/B
D21XL	UCB7	CS038R & CS039R
D22XL	UCB8	CS033RA/B & CS034RA/B & CS035RA/B
D23XL	UCB09	CS014F
D24XL	UCB09	CS036R & CS037R
D25XL	UCB4	CS006R & CS007R & CS008R
D26XL	UCB15	CS062R & CS063R
D27XL	UCB10	CS048R
D28XL	-	CS055R
D29XL	UCB17	¹ CS047R
D30XL	UCB17	CS016F
D31XL	UCB19	CS150R & CS151R
D32XL	UCB10	CS053R & CS054R & CS022R
D34XL	UCB19	¹ CS049R & CS056R & CS060R & ¹ CS068R & ¹ CS069R
D35XL	UCB17	CS057R & CS058R & CS070R
D36XL	-	CS059R
D37XL	-	CS061R
D38XL	UCB17	CS064R & CS065R
D43XL	-	CS046RA & CS046RB
EL13XL	-	EL043R & EL044R & EL045R & EL071R
EL14XL	-	¹ EL013R & ¹ EL014R & ¹ EL015R & ¹ EL066R & EL079R & EL080R & EL081R & EL082R
EL34XL	-	EL049R & EL068R & EL069R
EL39XL	-	EL072R & EL073R & EL074R
EL40XL	UCB21	EL077R
EL43XL	-	¹ EL083R & ¹ EL084R & EL085R
EL44XL	-	EL086R
EL45XL	UCB19	EL089R & EL090R & EL091R
EL46XL	UCB17	EL095R & EL096R
TSXL01	UCB10	CS048R

* FK01 U Bolt Thread Spacer Kit required on all Cab Chassis Models.

1. When remaining stock is exhausted no further product will be available.

REMOVING A LEAF:

In general terms, to reduce a springs rate remove the third leaf from the top of the spring.

Except if the third leaf is fitted with a spring clip, in this case remove the fourth leaf.

SPECIFICATIONS - LEAF SPRINGS

REPLACEMENT MAIN & SECOND LEAF

PART NUMBER	OME SPRING PART NUMBER	MAIN LEAF PART NUMBER	SECOND LEAF PART NUMBER
FRONT SPRINGS			
CS001F, CS002F	¹ 40 SERIES - OME13, OME131	SL1F/1	SL1F/2
CS003F, CS004F, CS005F	¹ 60 SERIES - OME110, OME111, OME111	SL3F/1	SL3F/2
CS006F, CS007F	¹ 75 SERIES - OME67, OME671	SL6F/1	SL6F/2
CS008FA	¹ HILUX - OME99A	SL8FA/1	SL8FA/2
CS008FB	¹ HILUX - OME99B	SL8FB/1	SL8FB/2
CS009FA	¹ HILUX - OME91A	SL9FA/1	SL9FA/2
CS009FB	¹ HILUX - OME91B	SL9FB/1	SL9FB/2
CS010FA, CS011FA	¹ PATROL M60 - OME3A, OME31A	SL10FA/1	SL10FA/2
CS010FB, CS011FB	¹ PATROL M60 - OME3B, OME31B	SL10FB/1	SL10FB/2
CS012FA, CS013FA	¹ SUZUKI SIERRA - OMES1A	SL12FA/1	SL12FA/2
CS012FB, CS013FB	¹ SUZUKI SIERRA - OMES1B	SL12FB/1	SL12FB/2
CS014F	¹ JEEP YJ - OMEJ1F	SL14F/1	SL14F/2
REAR SPRINGS			
CS001R, CS002R	¹ 40 SERIES - OME14, OME141	SL1R/1	SL1R/2
CS003R	¹ 45 SERIES - OME201	SL3R/1	SL3R/2
CS004RA, CS005RA	¹ 60 SERIES - OME113A, OME1131A	SL4RA/1	SL4RA/2
CS004RB, CS005RB	¹ 60 SERIES - OME113B, OME1131B	SL4RB/1	SL4RB/2
CS006R, CS007R, CS008R	¹ 75 SERIES - OME39, OME391, OME3911, OME39111	SL6R/1	SL6R/2
CS009R, CS010R	¹ HILUX - OME17, OME171, OME1711	SL9R/1	SL9R/2
CS011R, CS012R	¹ PATROL M60 - OME4, OME41	SL11R/1	SL11R/2
¹ CS013R, ¹ CS014R, ¹ CS015R	¹ 78/79 SERIES - OME49, OME491, OME492, OME493	SL13R/1	SL13R/2
CS016RA	¹ PATROL Y60, Y61 CAB CHASSIS - OME61A, OME611A	SL16RA/1	SL16RA/2
CS016RB	¹ PATROL Y60, Y61 CAB CHASSIS - OME61B, OME611B	SL16RB/1	SL16RB/2
CS017RA	¹ HJ60 - OME221A	SL17RA/1	SL17RA/2
CS017RB	¹ HJ60 - OME221B	SL17RB/1	SL17RB/2
CS018R, CS019R, CS020R, CS021R	¹ HILUX - OME180, OME18, OME181, OME1811	SL18R/1	SL18R/2
CS022R, CS023R	¹ TRITON / PAJERO - OME22, OME222	SL22R/1	SL22R/2
CS062R, CS063R	¹ ISUZU / RODEO 2003 - OMEROD4, OMEROD5	SL24R/1	SL24R/2
CS026R, CS027R	¹ MAZDA / FORD UTE - OME26, OME261	SL26R/1	SL26R/2
CS028R, CS029R	¹ ISUZU / RODEO - OMEROD1, OMEROD11, OMEROD111	SL28R/1	SL28R/2
CS030R, CS031R, CS032R	¹ NAVARA D21, D22 - OMENN1, OMENN11, OMENN2	SL30R/1	SL30R/2
CS033RA	JEEP XJ - 75mm	SL33RA/1	D22XL
CS033RB	JEEP XJ - 75mm	SL33RB/1	D22XL
CS034RA, CS035RA	¹ JEEP XJ - OMEJC1A, OMEJC2A	SL34RA/1	SL34RA/2
CS034RB, CS035RB	¹ JEEP XJ - OMEJC1B, OMEJC2B	SL34RB/1	SL34RB/2
CS036R, CS037R	¹ JEEP YJ - OMEJ1R, OMEJ2R	SL36R/1	SL36R/2
CS038R, CS039R	¹ SUZUKI SIERRA - OMES2, OMES21	SL38R/1	SL38R/2
¹ CS043R, ¹ CS044R, ¹ CS045R, ¹ CS071R	HILUX 2005 TO 2015	SL43R/1	SL43R/2
¹ CS049R, CS056R, CS060R	RANGER / BT-50 12/2006 TO 2011	SL49R/1	SL49R/2
CS053R, CS054R	TRITON ML & MN 2006 TO 2015	SL22R/1	SL53R/2
CS062R	COLORADO, DMAX 2008 TO 2011, RODEO 2003 TO 2008	SL62R/1	SL62R/2
CS063R	COLORADO, DMAX 2008 TO 2011, RODEO 2003 TO 2008	SL62R/1	SL63R/2
CS064R, CS065R	AMAROK 2010 ON	SL64R/1	SL64R/2
¹ CS066R	78/79 SERIES	SL13R/1	SL66R/2
¹ CS068R, ¹ CS069R	RANGER / BT-50 2011 ON	SL49R/1	SL49R/2
CS150R, CS151R	NAVARA D40	SL150R/1	D31XL

1. When remaining stock is exhausted no further product will be available.

SPECIFICATIONS - LEAF SPRINGS

U BOLTS

OE spring stack height must be compared to OME spring before final

U Bolt selection as OE spring stack heights may vary from model to model.

PART NO.	A LEG LENGTH mm	B LEG CENTRE mm	C THREAD DIA mm	D THREAD LENGTH mm	THREAD PITCH	E TOP TYPE	REC. TORQUE Lbs.ft.	REC. TORQUE Nm
OMEU51	210	85	14	70	1.5	SQUARE	93	126
OMEU52	200	76	14	75	1.5	FLAT	93	126
OMEU53	168	75	14	70	1.5	SQUARE	93	126
OMEU53A	185	75	14	65	1.5	SQUARE	93	126
OMEU53B	200	75	14	70	1.5	SQUARE	93	126
OMEU54	175	85	12	70	1.25	ROUND	58	79
OMEU55	218	97	14	70	1.5	SQUARE	93	126
OMEU56	100	75	12	50	1.25	SQUARE	58	79
OMEU57	190	88	12	70	1.25	ROUND	58	79
OMEU58	210	110	14	75	1.5	ROUND	93	126
OMEU58B	242	110	14	75	1.5	ROUND	93	126
OMEU59A	197	97	14	75	1.5	ROUND	93	126
OMEU59B	225	97	14	75	1.5	ROUND	93	126
OMEU59C	240	97	14	75	1.5	ROUND	93	126
OMEU59D	197	97	14	90	1.5	ROUND	93	126
OMEU60	150	81	11	70	1.27	ROUND	45	61
OMEU61	147	87	10	60	1.25	ROUND	34	45
OMEU61B	160	87	10	70	1.25	ROUND	34	45
OMEU62	145	73	10	70	1.25	ROUND	34	45
OMEU63	190	74	12	50	1.25	SQUARE	58	79
OMEU64	260	125	14	90	1.5	ROUND	93	126
OMEU65	215	97	14	75	1.5	ROUND	93	126
OMEU66	190	103	14	60	1.5	ROUND	93	126
OMEU66A	210	103	14	60	1.5	ROUND	93	126
OMEU66B	230	102	14	60	1.5	ROUND	93	126
OMEU67	350	107	16	75	2.0	ROUND	145	197
OMEU68	275	107	16	75	2.0	ROUND	145	197
OMEU69	235	95	14	65	2.0	ROUND	93	126
OMEU69A	260	95	14	65	2.0	ROUND	93	126
OMEU70	205	95	14	55	2.0	SQUARE	93	126
OMEU70A	230	95	14	55	2.0	SQUARE	93	126
OMEU71	150	82	12	60	1.5	SQUARE	58	79
OMEU72	200	97	14	90	1.5	ROUND	93	126
OMEU73	125	91	10	40	1.25	ROUND	34	45
OMEU76	170	84	12	50	1.5	SQUARE	58	79
OMEU77	325	97	16	110	2.0	SEMI ROUND	145	197
OMEU78	410	97	16	110	2.0	SEMI ROUND	145	197
OMEU79	295	107	16	110	2.0	ROUND	145	197
OMEU80	380	107	16	110	2.0	ROUND	145	197

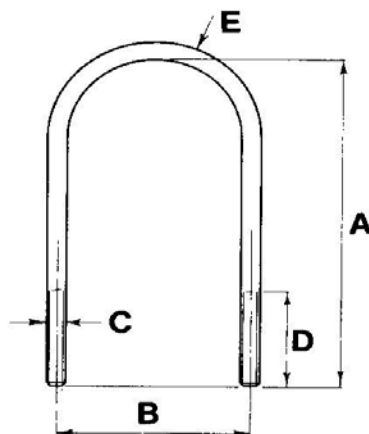

SPECIFICATIONS - LEAF SPRINGS

REPLACEMENT CENTRE BOLTS

Centre Bolt	Dimension Details						Spring Part No.
	Head A	Head B	Shank C	Shank D	Thread E	Thread	
UCB1	17	10	90	9.5	50	3/8 UNF	CS011R, 12R
UCB2	15	15	90	9.5	50	3/8 UNF	CS004RA/B, 17RA/B
UCB3	14	11	70	9.5	50	3/8 UNF	CS003F, 4F, 5F
UCB4	14	8	110	9.5	50	3/8 UNF	CS003R, 6R, 7R, 8R
UCB5	14	8	70	9.5	50	3/8 UNF	CS006F, 07F, 10FA/B, 11FA/B, 22R, 23R, 40R, 41R, 42R, 53R, 54R
UCB6	14	8	80	7.9	50	5/16 UNF	CS009R, 10R, 18R, 19R, 20R, 21R
UCB7	14	5	55	7.9	35	5/16 UNF	CS008FA/B, 9FA/B, 12FA/B, 13FA/B, 38R, 39R
UCB8	12	9	75	7.9	50	5/16 UNF	CS001F, 2F, 1R, 2R, 33RA/B, 34RA/B, 35RA/B
UCB09	13	10	55	7.9	40	5/16 UNF	CS014F, 36R, 37R
UCB10	14	8	120	9.5	40	3/8 UNF	CS008R, 48R, EL081R, 82R, 84R, 85R
UCB11	17	10	115	9.5	40	3/8 UNF	CS016RA/B
UCB12	11	8	70	7.9	40	5/16 UNF	CS028R
UCB13	14	6	70	9.5	40	3/8 UNF	CS030R, 31R, 32R
UCB14	14	6	80	9.5	40	3/8 UNF	CS030R, 31R, 32R, ¹ 43R, 43R-15, ¹ 44R, ¹ 45R, 46RA/B, ¹ 71R
UCB15	11.5	9	72	7.9	30	5/16 UNF	¹ CS024R, ¹ 25R, 62R, 63R
UCB16	11	8	80	7.9	40	5/16 UNF	CS028R, 29R
UCB17	14	8	90	9.5	50	3/8 UNF	¹ CS013R, ¹ 14R, ¹ 15R, 26R, 27R, ¹ 47R, 57R, 58R, 64R, 65R, ¹ 66R, EL095R, 96R
UCB18	16	8	50	10	30	M10	¹ CS015F, 18F
UCB19	14	8	95	10	45	M10	CS018R, ¹ 49R, ¹ 50R, ¹ 51R, 56R, 60R, 150R, 151R, EL043R, 44R, 45R, 49R, 68R, 69R, 71R, 72R, 73R, 74R, 79R, 80R, 83R, 86R, 87R, 88R, 89R, 90R, 91R
UCB20	16	8	62	10	45	M10	CS018F
UCB21	14	8	155	10	50	M10	EL077R With Overload Leaf

1. When remaining stock is exhausted no further product will be available.

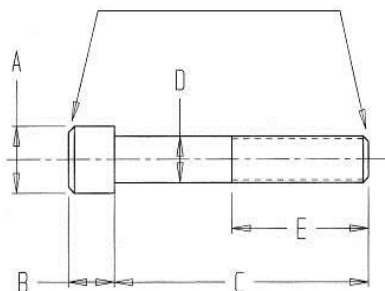

SPECIFICATIONS - LEAF SPRINGS

LEAF SPRING SERVICE PARTS

SPRING EYE SLEEVES			
PART NUMBER	ID (MM)	OD (MM)	LENGTH (MM)
CBH154028	15	40	28
CBH27532569	27.5	32.5	69
CBH303549	30	35	49
CBH303559	30	35	59
CBH31536559	31.5	36.5	59
CBH31536569	31.5	36.5	69
CBH32737759	32.7	37.7	59
CBH354069	35	40	69
CBH37542559	37.5	42.5	59
CBH39544559	39.5	44.5	59
CBH404549	40	45	49
CBH404559	40	45	59
CBH404569	40	45	69

SPRING CLIPS			
PART NUMBER	LEAF WIDTH (MM)	CLIP WIDTH (MM)	CLIP LENGTH (MM)
2512074	70	25	120
2516474	70	25	164

RIVETS		
PART NUMBER	SIZE	LENGTH (MM)
3822	3/8	22
3824	3/8	24

BONDED RUBBER BUSHES			
PART NUMBER	ID (MM)	OD (MM)	LENGTH (MM)
CBH14405970	14	40	59/70
CBH14406073	14	40	60/73
CBH145357889	14.5	35	78/89
CBH148517689	14.8	51	76/89
CBH16455689	16	45	56/89
CBH185396489	18.5	39	64/89
CBH18544489	18	54	44/89

LEAF LINER KITS	
PART NUMBER	DESCRIPTION
IL01YE (Round)	Inter Leaf Liners x 6 Pieces
SLK60 (60mm Wide)	Noise - Service Liners x 4 Pieces
SLK70 (70mm Wide)	Noise - Service Liners x 4 Pieces
SLO0350413	Inter Leaf Liners Small (Each)
SLO0530413	Inter Leaf Liners Large (Each)

EL SERVICE KITS	
PART NUMBER	DESCRIPTION
TB1001	TRU BLU NLGI2.9 Grease 450gm
TB1002	TRU BLU NLGI2.9 Grease 2.5kg
TB1003	TRU BLU NLGI2.9 Grease 20kg
ELSK01	Leaf Spring Clip Liner Kit
ELSK02	Interleaf Liners x 10
ELSK03	Leaf Spacers 1.6mm 60 Wide
ELSK04	Leaf Spacers 1.6mm 70 Wide
ELSK05	Leaf Trim Packer 10mm 60 Wide
ELSK06	Leaf Trim Packer 10mm 70 Wide
ELSK07	Caster Wedge 2° 60 Wide
ELSK08	Caster Wedge 2° 70 Wide
ELSK09	Caster Wedge 3.5° 60 Wide

SPECIFICATIONS - LEAF SPRINGS

LEAF SPRING TRIM PACKERS

(Mild Steel 5mm Thick)

Part No.	Width	Length	Hole Dia.	Applications
TP01	70mm	140mm	10.3mm	TOYOTA 60, 75, NISSAN GQ / FORD MAVERICK CAB CHASSIS & NISSAN GQ UTE
TP02	70mm	140mm	8.7mm	TOYOTA 40, 42, 45, 47
TP03	60mm	140mm	10.3mm	NISSAN MQ, MITSUBISHI PAJERO, TRITON, L200
TP04	60mm	140mm	8.7mm	TOYOTA HILUX, 4RUNNER
TP05	50mm	120mm	8.7mm	SUZUKI SIERRA, SAMURAI (SJ413), SANTANA SAMURAI, HOLDEN DROVER

To be used to correct left to right trim problems. Maximum 2 plates (10mm). Order centre bolt separately.
Refer Manual for Instructions.

CLIP LINER KITS FOR LEAF SPRINGS

Kit Part No.	Contents: Clip Liner Size & Quantity	To Suit OME	To Suit
CLK11	20mm X 4	¹ OME110, 11, 111, J1F	CS003F, 4F, 5F
CLK113A	30mm X 4, 90mm X 2	¹ OME113A, 1131A	CS004RA, 5RA
CLK113B	30mm X 4, 80mm X 2	¹ OME113B, 1131B	CS004RB, 5RB
CLK13	40mm X 4	¹ OME13, 131	CS001F, 2F
CLK14	30mm X 4, 60mm X 2	¹ OME14, 141	CS001R, 2R
CLK17	35mm X 4, 70mm X 2	¹ OME17, 171	CS009R, 10R, 28R, 29R, 53R, 54R
CLK18	30mm X 4, 90mm X 2	¹ OME18, 181, 1811	CS018R, 19R, 20R
CLK201	40mm X 4, 80mm X 2	¹ OME201	CS003R
CLK22	35mm X 4, 40mm X 2	¹ OME22, 222	CS022R, 23R
CLK221	20mm X 4, 40mm X 2	¹ OME221A/B	CS017RA/B
CLK3	30mm X 4	¹ OME3A/B, 31A/B, JC1A/B	CS010FA/B, 11FA/B, 34RA/B
CLK39	50mm X 4, 80mm X 2	¹ OME39, 391, 3911, 39111	CS006R, 7R, 8R, ¹ 68R
CLK4	40mm X 4	¹ OME4, 41	CS011R, 12R, ¹ 49R, 56R, 61R
CLK57	30mm X 4, 35mm X 2	¹ OME67, 671	CS006F, 7F
CLK6	45mm X 4, 95mm X 2	¹ OME6A/B, 61A/B, 611A/B	CS016RA/B, 42R, 46RA/B, ¹ 47R
CLK9	35mm X 2, 30mm X 2	¹ OME91A/B, 99A/B	CS008FA/B, 9FA/B
CLKJ1	25mm X 4	¹ OMEJ1R	CS036R
CLKJ2	30mm X 4, 80mm X 2	¹ OMEJC2A, JC2B	CS035RA/B
CLKNN	80mm X 2	¹ OMENN1, NN11, NN2	CS030R, 31R, 32R
CLKROD	30mm X 4, 70mm X 2	¹ OMEROD1, ROD11, ROD4, ROD5	¹ CS024R, ¹ 25R, 62R, 63R
CLK13D	35mm X 4		CS013FA/B, 14F
CLK15D	55mm X 4, 150mm X 2		¹ CS013R, ¹ 14R, ¹ 15R, 60R, ¹ 66R, ¹ 69R
CLK26D	45mm X 2, 95mm X 2	¹ OME26, 261	CS026R, 27R
CLK33D	40mm X 4, 85mm X 2		CS033RA, CS033RB, 150R, 151R
CLK38D	20mm X 4, 65mm X 2		CS038R, 39R
CLK40D	60mm X 2		CS040R, 41R
CLK43D	35mm X 2, 45mm X 4, 85mm X 2		¹ CS043R, ¹ 44R, ¹ 45R, ¹ 71R
CLK48D	47mm X 2		CS048R
CLK55D	40mm X 2, 50mm X 2		CS055R
CLK57D	35mm X 2, 120mm X 2		CS057R
CLK58D	45mm X 2, 115mm X 2		CS058R, 70R

1. When remaining stock is exhausted no further product will be available.

INTER-LEAF LINER KIT FOR LEAF SPRINGS

IL01YE	6 LINERS PER KIT
SLK60	4 LEAF SLEEVES TO SUIT 60MM WIDTH
SLK70	4 LEAF SLEEVES TO SUIT 70MM WIDTH
SLO0350413	I/LEAF LINER SMALL 4MM THICK
SLO0530413	I/LEAF LINER LARGE 4MM THICK

LEAF SPRING CENTRE BOLT SLEEVES

Part No.	Length mm	OD mm	ID mm	Application
CBS01	15	25	15	LandCruiser 60 series rear
CBS02	10	19	16.8	GQ Patrol cab chassis front

SPECIFICATIONS - LEAF SPRINGS

LEAF SPRINGS

Part No.	OME Part No.	Stack Height (mm)	No. of Leaves	Eye Dia. mm		Weight (kg)	Primary Free Camber mm	Spring Rate	
				Front	Rear			lbf / in	N / mm
CS001F	¹ OME13	48.0	8	35.0	35.0	23.0	165	350	61.3
CS001R	¹ OME14	43.0	5 + 1	35.0	35.0	21.5	225	300 / 450	52.5 / 79
CS002F	¹ OME131	54.0	9	35.0	35.0	27.0	165	398	69.8
CS002R	¹ OME141	49.0	6 + 1	35.0	35.0	25.6	225	357 / 496	62.5 / 87
CS003F	¹ OME110	30.0	5	35.0	35.0	15.5	200	220	38.5
CS003R	¹ OME201	81.0	6 + 3	35.0	35.0	45.4	235	510 / 710	90 / 125
CS004F	¹ OME11	36.0	6	35.0	35.0	17.7	196	257	45
CS004RA	¹ OME113A	58.0	6 + 2	35.0	35.0	31.6	250	268 / 570	47.0 / 100
CS004RB	¹ OME113B	58.0	6 + 2	35.0	35.0	31.6	230	268 / 570	47.0 / 100
CS005F	¹ OME111	42.0	7	35.0	35.0	21.5	196	305	53.5
CS005RA	¹ OME1131A	64.0	7 + 2	35.0	35.0	36.0	250	314 / 617	55 / 108
CS005RB	¹ OME1131B	64.0	7 + 2	35.0	35.0	36.0	230	314 / 617	55 / 108
CS006F	¹ OME67	43.0	7	35.0	35.0	21.6	220	302	53
CS006R	¹ OME391	82.0	7 + 3	40.0	40.0	46.8	240	388 / 610	68 / 107
CS007F	¹ OME671	49.0	8	35.0	35.0	25.5	220	348	61
CS007R	¹ OME3911	89.0	8 + 3	40.0	40.0	52.2	240	455 / 600	80 / 105
CS008FA	¹ OME99A	32.5	5	30.0	30.0	14.8	170	208	36.5
CS008FB	¹ OME99B	32.5	5	30.0	30.0	14.8	150	208	36.5
CS008R	¹ OME39111	96.0	9 + 3	40.0	40.0	59.5	240	500 / 656	88 / 115
CS009FA	¹ OME91A	39.0	6	30.0	30.0	18.4	170	254	44.5
CS009FB	¹ OME91B	39.0	6	30.0	30.0	18.4	150	254	44.5
CS009R	¹ OME17	48.0	4 + 2	30.0	30.0	20.0	230	217 / 388	38.0 / 68.0
CS010FA	¹ OME3A	43.0	7	32.5	32.5	18.9	215	283	49.6
CS010FB	¹ OME3B	43.0	7	32.5	32.5	18.9	200	283	49.6
CS010R	¹ OME171	54.5	5 + 2	30.0	30.0	24.2	230	285 / 445	50.0 / 78.0
CS011FA	¹ OME31A	49.0	8	32.5	32.5	22.3	215	343	60
CS011FB	¹ OME31B	49.0	8	32.5	32.5	22.3	200	343	60
CS011R	¹ OME4	56.0	8	32.5	32.5	26.8	275	211	37
CS012FA	¹ OMES1A	24.4	4	30.0	40.0	8.1	125	207	36.3
CS012FB	¹ OMES1B	24.4	4	30.0	40.0	8.1	110	207	36.3
CS012R	¹ OME41	63.0	9	32.5	32.5	30.2	275	240	42
CS013FA	N/A	30.0	5	30.0	40.0	10.4	125	247	27.9
CS013FB	N/A	30.0	5	30.0	40.0	10.4	110	247	27.9
¹ CS013R	¹ OME491	68.0	5 + 2	40.0	40.0	47.9	268	279 / 548	52 / 96
CS014F	¹ OMEJ1F	26.0	4	31.4	37.6	11.0	210	148	26
¹ +CS014R	¹ +OME492	68.0	5 + 2	40.0	40.0	47.9	268	279 / 548	52 / 96
¹ CS015F	N/A	52.0	6	52.0	42.0	33.0	190	369	65
¹ +CS015R	¹ +OME493	76.0	6 + 2	40.0	40.0	51.5	268	325 / 680	57 / 119
CS016F	N/A	56.0	8	32.7	40.0	27.0	229	337	59
CS016RA	¹ OME611A	82.0	7 + 3	40.0	40.0	50.8	250	325 / 585	57 / 103
CS016RB	¹ OME611B	82.0	7 + 3	40.0	40.0	50.8	235	325 / 585	57 / 103
CS017RA	¹ OME221A	48.0	8	35.0	35.0	25.5	250	255	44.7
CS017RB	¹ OME221B	48.0	8	35.0	35.0	25.5	230	255	44.7
CS018F	N/A	58.0	7	51.5	41.5	37.7	202	431	75.5
*CS018R	¹ *OME180	52.5	3 + 3	39.0	30.0	25.0	215	125 / 485	22 / 85
CS019R	¹ OME18	52.5	3 + 3	39.0	30.0	27.3	235	125 / 485	22 / 85
CS020R	¹ OME181	59.0	4 + 3	39.5	30.0	30.6	235	160 / 540	28 / 95
CS021R	¹ OME1811	65.5	5 + 3	39.0	30.0	31.0	235	274 / 571	48 / 100
CS022R	¹ OME22	41.0	5 + 1	31.5	27.5	22.0	195	194 / 388	34.0 / 68.0
+CS023R	¹ +OME222	58.0	6 + 2	31.5	27.5	29.5	195	230 / 570	41 / 100
¹ CS024R	¹ OMEROD4	54.0	4 + 2	39.0	30.0	22.0	181	205 / 450	36 / 79
CS026R	¹ OME26	59.0	4 + 3	32.7	32.7	26.3	164	177 / 616	31 / 108

Free Camber is measured from top of eye (not centre line) to main leaf at centre bolt. Allow 3mm tolerance either side.

cont.

* These springs have a 20mm lower 2nd Stage than other springs in the series.

+ These springs have a 20mm higher 2nd stage than other springs in the series.

1. When remaining stock is exhausted no further product will be available.

SPECIFICATIONS - LEAF SPRINGS

LEAF SPRINGS

Part No.	OME Part No.	Stack Height (mm)	No. of Leaves	Eye Dia. mm		Weight (kg)	Primary Free Camber mm	Spring Rate	
				Front	Rear			lbf / in	N / mm
CS027R	¹ OME261	65.5	5 + 3	32.7	32.7	30.1	164	217 / 662	38 / 116
CS028R	¹ OMEROD11	48.0	4 + 2	39.0	30.0	22.5	250	170 / 457	30 / 80
+CS029R	¹ +OMEROD111	60.5	4 + 3	39.0	30.0	25.4	250	216 / 616	38 / 108
CS030R	¹ OMENN1	52.5	3 + 3	40.0	32.5	22.1	170	126 / 531	22 / 93
CS031R	¹ OMENN11	59.0	4 + 3	40.0	32.5	25.5	170	165 / 571	29 / 100
*CS032R	¹ *OMENN2	52.5	3 + 3	40.0	32.5	22.1	170	126 / 411	22 / 72
CS034RA	¹ OMEJC1A	32.5	5	62.0	43.5	18.2	230	148	26
CS034RB	¹ OMEJC1B	32.5	5	62.0	43.5	18.2	205	148	26
CS035RA	¹ OMEJC2A	37.0	4 + 1	62.0	43.5	20.9	235	137 / 257	24 / 45
CS035RB	¹ OMEJC2B	37.0	4 + 1	62.0	43.5	20.9	210	137 / 257	24 / 45
CS036R	¹ OMEJ1R	32.5	5	37.6	31.4	13.7	205	188	33
CS037R	¹ OMEJ2R	32.5	5	37.0	31.0	13.8	185	188	33
CS038R	¹ OMES2	36.0	3 + 2	40.0	30.0	9.8	175	171 / 291	30 / 51
CS039R	¹ OMES21	42.0	4 + 2	40.0	30.0	12.3	175	228 / 348	40 / 61
CS040R	¹ OME19	29.0	3 + 1	31.5	27.5	16.4	211	148 / 245	26 / 43
CS041R	¹ OME191	35.0	4 + 1	31.5	27.5	16.4	211	200 / 296	35 / 52
CS042R	¹ OME36	45.0	4 + 1	46.8	31.0	28.0	210	228 / 310	40 / 55
¹ CS043R	N/A	50.0	4 + 2	40.0	30.0	24.0	194	170 / 340	30 / 60
CS043R-15	N/A	50.0	4 + 2	40.0	30.0	24.0	179	170 / 340	30 / 60
¹ CS044R	N/A	50.0	4 + 2	40.0	30.0	24.0	204	170 / 340	30 / 60
¹ +CS045R	N/A	57.0	5 + 2	40.0	30.0	27.5	204	204 / 361	35.8 / 63.8
CS046RA	¹ OME15A	52.0	5 + 2	40.5	30.0	26.7	222	114 / 194	20 / 34
CS046RB	¹ OME15B	52.0	5 + 2	40.5	30.0	26.7	209	114 / 194	20 / 34
¹ CS047R	N/A	57.0	5 + 2	40.0	40.0	32.4	207	182 / 392	32 / 69
CS048R	N/A	50.0	3 + 2	40.0	40.0	32.5	275	225 / 416	39 / 73
¹ CS049R	N/A	45.0	4 + 1	40.0	32.7	25.0	173	212 / 450	37 / 79
¹ CS051R / CS151R	N/A	67.0	5 + 2	40.0	33.4	36.25	177	244 / 535	43 / 94
CS053R	N/A	35.0	4 + 1	31.5	27.5	20.3	193	166 / 321	29 / 56
CS054R	N/A	41.0	5 + 1	30.0	27.5	24.3	193	209 / 365	37 / 64
CS055R	N/A	65.0	4 + 2	40.0	40.0	36.5	190	205 / 330	36 / 58
CS056R	N/A	37.0	3 + 1	40.0	32.7	20.0	173	147 / 371	26 / 65
CS057R	N/A	59.0	4 + 2	40.0	40.0	36.6	225	234 / 627	41 / 110
CS058R	N/A	66.0	5 + 2	40.0	40.0	42.8	260	300 / 694	53 / 122
CS059R	N/A	55.0	4 + 1	51.0	43.0	22.9	265	242 / 338	43 / 59
CS060R	N/A	70.0	5 + 2	40.0	32.7	33.12	138	277 / 608	49 / 107
CS061R	N/A	58.0	4 + 2	40.0	32.7	24.9	208	186 / 352	32.7 / 61.7
CS062R	N/A	60.0	5 + 2	39.0	30.0	26.0	223	215 / 459	38 / 80
CS063R	N/A	64.0	5 + 2	39.0	30.0	28.0	226	294 / 610	52 / 107
CS064R	N/A	58.0	4 + 2	60.0	46.0	39.2	266	169 / 445	30 / 78
CS065R	N/A	69.0	5 + 2	60.0	46.0	48.2	266	267 / 582	47 / 102
¹ CS066R	N/A	92.0	8 + 2	40.0	40.0	59.6	266	412 / 679	72 / 119
¹ CS068R	N/A	66.0	5 + 2	40.0	32.7	33.1	163	277 / 608	49 / 107
¹ CS069R	N/A	80.0	6 + 2	40.0	32.7	37.0	148	338 / 707	59 / 124
CS070R	N/A	83.0	7 + 2	40.0	40.0	50.0	253	408 / 684	71 / 120
¹ CS071R	N/A	64.0	6 + 2	40.0	30.0	31.1	199	258 / 434	42 / 76
CS150R	N/A	59.0	4 + 2	40.0	33.4	30.9	177	192 / 481	34 / 84
¹ EL013R	¹ CS013R	68.0	5 + 2	40.0	40.0	47.2	253	245 / 510	43 / 90
¹ EL014R	¹ CS014R	68.0	5 + 2	40.0	40.0	47.2	280	245 / 510	43 / 90
¹ EL015R	¹ CS015R	76.0	6 + 2	40.0	40.0	53.9	272	294 / 542	52 / 95
EL043R	¹ *CS043R	50.0	4 + 2	40.0	30.0	22.6	175	170 / 340	30 / 60
EL044R	¹ CS044R	50.0	4 + 2	40.0	30.0	22.6	186	170 / 340	30 / 60

Free Camber is measured from top of eye (not centre line) to main leaf at centre bolt. Allow 3mm tolerance either side.

cont.

* These springs have a 20mm lower 2nd Stage than other springs in the series.

+ These springs have a 20mm higher 2nd stage than other springs in the series.

1. When remaining stock is exhausted no further product will be available.

SPECIFICATIONS - LEAF SPRINGS

LEAF SPRINGS

Part No.	OME Part No.	Stack Height (mm)	No. of Leaves	Eye Dia. mm		Weight (kg)	Primary Free Camber mm	Spring Rate	
				Front	Rear			lbf / in	N / mm
EL045R	¹ CS045R	57.0	5 + 2	40.0	30.0	26.9	206	204 / 361	36 / 63
EL049R	¹ CS049R	44.0	4 + 1	40.0	32.7	24.1	161	218 / 403	38 / 71
¹ EL066R	¹ CS066R	92.0	8 + 2	40.0	40.0	58.2	263	412 / 680	72 / 119
EL068R	¹ CS068R	66.0	5 + 2	40.0	32.7	32.2	155	277 / 608	49 / 107
EL069R	¹ CS069R	74.0	6 + 2	40.0	32.7	36.0	147	338 / 707	59 / 124
EL071R	¹ CS071R	64.0	6 + 2	40.0	30.0	30.5	200	258 / 434	45 / 76
EL072R	N/A	53.0	3 + 2	40.0	30.0	27.8	199	193 / 432	34 / 76
EL073R	N/A	61.0	4 + 2	40.0	30.0	32.7	203	250 / 515	44 / 90
EL074R	N/A	69.0	5 + 2	40.0	30.0	37.5	202	307 / 544	54 / 101
EL077R	N/A	82.3	7 + 1	42.0	42.0	59.6	271	301 / 643	53 / 113
EL079R	N/A	68.0	5 + 2	40.0	40.0	47.2	243	245 / 510	43 / 89
EL080R	N/A	68.0	5 + 2	40.0	40.0	47.2	255	245 / 510	43 / 89
EL081R	N/A	76.0	6 + 2	40.0	40.0	54.0	255	325 / 689	57 / 121
EL082R	N/A	92.0	8 + 2	40.0	40.0	58.2	247	412 / 678	72 / 119
¹ EL083R	N/A	63.0	5 + 2	40.0	32.7	28.1	207	209 / 626	36 / 109
¹ EL084R	N/A	77.0	7 + 2	40.0	32.7	34.5	212	292 / 686	51 / 120
EL085R	N/A	84.0	7 + 2	40.0	32.7	39.2	196	416 / 829	73 / 145
EL086R	N/A	56.0	5 + 2	40.0	27.0	28.2	172	198 / 368	35 / 65
EL087R	N/A	63.0	6 + 2	40.0	27.0	32.5	184	241 / 398	42 / 70
EL088R	N/A	66.0	5 + 2	40.0	27.0	33.3	154	373 / 558	65 / 98
EL089R	N/A	52.0	4 + 2	40.0	30.0	26.0	195	169 / 300	30 / 53
EL090R	N/A	62.0	5 + 2	40.0	30.0	31.9	188	220 / 389	39 / 68
EL091R	N/A	68.0	5 + 2	40.0	30.0	35.5	174	217 / 489	56 / 86
EL092R	N/A	51.0	5+1	40.0	32.7	25.0	207	209 / 505	36.6 / 88.5
EL093R	N/A	65.0	7+1	40.0	32.7	31.1	212	292 / 565	51.2 / 99.0
EL094R	N/A	70.0	7+1	40.0	32.7	35.8	196	416 / 590	72.8 / 103.4
EL095R	N/A	57.0	4+2	40.0	40.0	27.4	210	149 / 482	26.1 / 84.5
EL096R	N/A	64.0	5+2	40.0	40.0	31.9	210	182 / 506	31.9 / 88.6

Free Camber is measured from top of eye (not centre line) to main leaf at centre bolt. Allow 3mm tolerance either side.

1. When remaining stock is exhausted no further product will be available.

SPECIFICATIONS - COIL SPRINGS

COIL SPRINGS

Spring Number	X5K Steel	Bar Dia. mm	Free Height mm		Number Of Turns	Coil weight (kg)	Spring Rate		OE Spring Rate Lbs
			A	B			lbf / in	N / mm	
2105 ¹	X	19	475	485	9.0	8.5	350	61	160
2106 ¹	X	21	460	470	8.3	11.3	400 / 440	70 / 77	170
2412	X	17	460	445	8.0	6.1	250	44	200
2413	X	17	485	470	8.0	6.1	250	44	200
2414	X	18	510	495	9.5	8.3	250	44	200
2415	X	19	510	495	7.7	8.5	290	51	180
2416	X	19	535	520	7.7	8.5	290	51	180
2417	X	19.5	560	545	8.3	9.9	290	51	180
2418	X	18	505	515	9.0	7.5	300	52	160
2419	X	18	530	540	9.0	7.5	300	52	160
2420	X	19	555	565	10.75	10.0	300	52	160
2421	X	19	480	490	7.7	8.5	280	49	170
2422	X	19	505	515	7.7	8.5	280	49	170
2423	X	19.5	530	540	8.3	9.9	280	49	170
2500 ¹	X	14.5	385	385	5.4	3.4	155	27	130
2501 ¹	X	15	350	350	7.3	4.3	175	31	130
2502 ¹	X	16	350	350	6.0	4.3	245	43	130
2503 ¹	X	15	342	342	7.0	4.1	185	32	130
2504 ¹	X	14.5	355	355	5.4	3.4	155	27	130
2505 ¹	X	15	330	330	7.3	4.3	175	31	130
2506 ¹	X	15	330	330	5.1	3.4	180	32	130
2507 ¹	X	15	338	338	5.1	3.5	180	32	160
2508 ¹	X	15	315	315	5.6	3.6	180	32	160
2509 ¹	X	17	360	360	5.4	4.7	250	44	200
2510 ¹	X	15	360	360	7.15	4.1	180	32	140
2511 ¹	X	13.5	345	345	6.6	2.8	190	33	160
2512	X	17.5	305	305	6.25	4.1	500	88	420
2513 ¹	X	14.5	345	345	6.63	3.3	250	44	200
2516 ¹	X	16	270	270	4.7	3.5	260	46	200
2517 ¹	X	16	280	280	4.7	3.5	260	46	200
2518 ¹	X	14.5	325	325	8.6	3.4	340	60	280
2519 ¹	X	15.5	355	355	5.7	4.1	190	33	140
2520 ¹	X	15	360	360	6.6	3.9	180	32	150
2523 ¹	X	16	300	300	8.0	4.1	500	88	440
2524 ¹	X	15	255	255	5.7	2.8	200	35	160
2525 ¹	X	15	340	340	5.75	3.8	215	38	160
2526 ¹	X	14.5	385	385	6.25	3.5	190	33	150
2527 ¹	X	19	385	385	5.0	6.5	240	42	180
2528 ¹	X	16	310	310	5.5	3.5	310	54	260
2529 ¹	X	14.5	375	375	7.51	3.6	230	40	180
2530 ¹	X	16	335	335	7.25	4.2	350	61	300
2531 ¹	X	14	315	315	6.5	3.0	230	40	190
2532 ¹	X	12	310	310	7.75	2.4	140	25	100
2533 ¹	X	16	450	450	11.0	5.3	355	62	260
2534 ¹	X	17	360	360	7.4	5.1	330	58	280
2535 ¹	X	14	370	370	7.5	3.3	200	35	160
2536	X	17	265	260	6.5	3.9	650	114	450
2538	X	17	265	260	6.5	3.9	650	114	450
2539 ¹	X	13.5	345	345	5.9	2.7	180	32	150
2540 ¹	X	16	300	300	7.0	3.7	420	74	350
2601	X	18	350	350	8.35	5.5	650	114	540
2602	X	16	392	392	8.22	5.6	180	32	150
2603	X	17	410	410	7.0	6.4	188	33	140
2604	X	17	400	400	6.0	5.5	227	38	140
2605	X	18	315	315	7.75	5.1	730	128	680
2606	X	18	320	320	7.75	5.1	730	128	680
2607	X	16.5	370	370	9.5	5.3	480	84	450
2608	X	16.5	380	380	9.5	5.3	480	84	450
2609	X	19	440	440	8.0	7.8	390	68	330

1. When remaining stock is exhausted no further product will be available.

cont.

SPECIFICATIONS - COIL SPRINGS

COIL SPRINGS

Spring Number	X5K Steel	Bar Dia. mm	Free Height mm		Number Of Turns	Coil weight (kg)	Spring Rate		OE Spring Rate Lbs
			A	B			lbf / in	N / mm	
2610	X	20	430	430	8.0	8.7	460	81	330
2611	X	18	310	310	7.75	5.1	730	128	680
2612	X	20	415	415	10.99	8.9	740	130	680
2613	X	20	435	435	10.99	8.9	740	130	680
2614	X	20	425	425	10.99	8.9	740	130	680
2615	X	13	510	510	10.0	3.7	120	21	120
2616	X	14	490	490	10.5	4.6	135	24	120
2617	X	15	430	430	7.0	4.1	160	28	100
2618	X	16	435	435	7.75	5.3	175	31	100
2619	X	14	515	515	10.5	4.6	135	24	120
2620	X	15	450	450	9.0	4.5	200	35	120
2621	X	14	520	520	9.55	4.1	150	26	120
2622	X	14.5	375	375	7.0	3.6	210	37	160
2623	X	15	375	375	6.1	3.8	200	35	160
2624	X	15	365	365	6.1	3.8	200	35	160
2625	X	17	345	345	8.5	4.8	540	95	460
2626	X	13	500	500	10.0	3.7	120	21	120
2627	X	14	475	475	10.5	4.6	135	24	120
2628	X	14	505	505	10.5	4.6	135	24	120
2629	X	14	505	505	9.55	4.1	150	26	120
2630	X	15	405	405	7.0	4.1	160	28	100
2631	X	17.5	375	375	9.9	5.9	580	102	88
2640 ¹	X	17.5	305	305	7.4	4.5	730	128	670
2641 ¹	X	18	310	310	7.4	4.8	790	139	670
2642	X	14	540	540	10.5	4.6	135	24	120
2643	X	14.5	460	460	9.0	4.2	175	31	100
2700	X	18	420	420	8.75	5.7	625	109	500
2701	X	19	425	425	9.48	6.9	720	126	500
2702	X	18.5	430	430	9.48	6.6	625	109	500
2703	X	19	435	435	9.48	6.9	720	126	500
2704	X	18	410	410	8.8	6.6	625	109	500
2705	X	19	415	415	9.5	6.9	720	126	500
2720	X	18.5	420	410	8.42	8.8	270 / 350	47 / 61	170
2721	X	18.5	440	430	8.42	8.8	270 / 350	47 / 61	170
2722	X	19	440	430	7.2	8.0	275	48	170
2723	X	20	450	440	7.2	8.9	340	59	170
2724	X	21	445	435	7.2	9.8	400	70	170
2725	X	22	445	435	7.71	11.6	440	77	170
2730	X	15.5	315	315	5.4	3.5	240	42	200
2731	X	15.5	300	300	5.0	3.1	280	49	200
2743	X	21	360	360	8.6	8.7	800	140	600
2744	X	18	400	400	9.7	6.5	530	93	480
2745	X	19	390	390	9.7	7.2	670	117	480
2746	X	20	370	370	8.6	7.9	680	119	600
2751	X	15	390	380	6.57	3.9	225	39	200
2752	X	17	440	440	9.0	7.7	175 / 200	31 / 35	200
2754	X	20	435	435	6.9	8.3	420	74	240
2755	X	18	435	435	6.8	6.5	300	52	240
2760	X	15	395	385	9.0	5.2	180 / 250	32 / 44	160
2761	X	15	400	390	7.5	4.4	200	35	160
2762	X	17.5	420	410	8.6	7.0	300 / 340	52 / 60	170
2763	X	18	420	410	7.8	6.7	360	63	200
2764	X	16	430	420	8.0	5.4	220	39	200
2765	X	22	410	410	8.0	11.7	540	95	240
2766	X	16	420	420	7.52	5.0	250	44	220
2767	X	16	385	375	6.66	4.5	285	50	200
2768	X	20	560	560	11.0	10.3	450	79	220
2770 ¹	X	16	480	470	10.0	6.5	260	45	160
2776	X	14	410	390	7.0	3.6	160	28	150

1. When remaining stock is exhausted no further product will be available.

cont.

SPECIFICATIONS - COIL SPRINGS

COIL SPRINGS

Spring Number	X5K Steel	Bar Dia. mm	Free Height mm		Number Of Turns	Coil weight (kg)	Spring Rate		OE Spring Rate Lbs
			A	B			lbf / in	N / mm	
2777	X	14.5	395	375	7.24	4.0	180	32	150
2779	X	15.5	385	375	7.29	4.6	225	39	150
2780 ¹	X	18.5	470	460	8.68	9.0	250 / 340	43 / 59	160
2781	X	17	425	415	7.7	5.9	290	51	160
2789 ¹	X	16	280	280	7.25	3.9	410	72	380
2790	X	17	378	378	9.35	5.2	500	87	400
2791	X	16	280	280	7.25	3.9	410	72	380
2792	X	14	435	435	9.3	4.1	155	27	130
2793	X	15	350	350	5.2	3.7	165	29	120
2794	X	16	260	255	7.25	4.2	420	73	330
2795	X	16	285	285	6.0	4.0	360	63	330
2796 ¹	X	16	255	250	7.25	4.2	420	73	330
2797	X	13	350	350	10.0	2.7	340	59	300
2798	X	13	400	400	10.2	3.2	210	36	180
2799 ¹	X	16	353	353	5.5	4.5	200	35	150
2802	X	16	445	445	11.31	5.9	320	56	205
2803	X	16	465	465	10.7	5.5	340	59	205
2838	X	18	420	410	7.5	7.7	205 / 290	36 / 51	160
2850	X	16.5	495	505	9.0	6.2	220	38	160
2850J	X	17	515	525	9.9	7.3	220	38	160
2851	X	16	475	485	8.18	5.3	220	38	160
2853	X	16.5	485	485	10.13	6.2	275	48	160
2856	X	16	465	465	10.0	5.3	230	40	210
2859	X	16	470	470	9.25	5.3	275	48	210
2860	X	17	480	490	6.88	6.0	220	38	170
2861	X	16	480	490	10.4	6.8	170 / 250	30 / 44	160
2862	X	17	460	470	9.0	7.8	170 / 260	30 / 46	160
2863	X	18	480	490	7.0	6.9	250	43	170
2863J	X	18.5	505	515	7.7	9.2	265	46	170
2864	X	19	480	490	7.2	7.8	320	56	170
2865	X	17	460	460	6.88	6.0	220	38	170
2866	X	18	465	465	9.0	8.8	240 / 300	42 / 52	170
2868	X	20	480	490	7.15	8.8	360	63	170
2869	X	16.5	380	380	9.8	4.7	590	103	500
2870	X	14	370	355	8.5	3.6	220	38	160
2871	X	16	410	400	7.25	4.9	220	38	160
2872	X	14	400	400	9.0	3.9	190	33	160
2873	X	16	455	455	8.25	5.6	200	35	160
2874	X	15	408	408	9.0	4.5	220	38	160
2875	X	17	440	440	8.3	6.4	240	42	170
2876	X	14	390	375	8.5	3.6	200	35	160
2880	X	16	365	365	10.2	4.7	500	87	490
2881	X	16	375	375	10.2	4.7	500	87	490
2882	X	16.5	395	395	11.1	5.3	500	87	490
2883	X	16.5	375	375	9.75	4.7	590	103	500
2884	X	16.5	390	390	9.75	4.7	590	103	500
2885	X	16.5	395	395	9.75	4.7	590	103	500
2885 01/09 On	X	17	395	395	10.75	4.7	590	103	500
2886	X	17.5	402	402	10.6	5.9	660	115	590
2887	X	16.5	400	400	9.75	4.7	590	103	500
2887 01/09 On	X	17	400	400	10.75	4.7	590	103	500
2888	X	16.5	405	405	9.75	4.7	590	103	500
2888 01/09 On	X	17	405	405	10.75	4.7	590	103	500
2889	X	16.5	400	400	6.21	4.6	260	45	150
2890	X	14.5	440	430	9.7	5.0	190	33	150
2891	X	15.5	425	415	9.5	5.6	210	37	150
2892	X	17	400	390	8.9	6.4	260 / 380	67	150
2895	X	16.5	390	390	6.21	4.6	260	45	150
2895E	X	17	375	375	6.75	5.4	260	45	150

1. When remaining stock is exhausted no further product will be available.

cont.

SPECIFICATIONS - COIL SPRINGS

COIL SPRINGS

Spring Number	X5K Steel	Bar Dia. mm	Free Height mm		Number Of Turns	Coil weight (kg)	Spring Rate		OE Spring Rate Lbs
			A	B			lbf / in	N / mm	
2896	X	18	390	390	6.75	6.1	318	56	150
2897	X	19	390	390	6.75	6.9	387	68	150
2898	X	18	400	400	6.75	6.1	318	56	150
2899	X	19	400	400	6.75	6.9	387	68	150
2900	X	15	405	395	6.36	4.1	180	32	140
2901	X	16	395	385	6.25	4.6	220	38	140
2902	X	18	340	340	8.35	5.5	650	114	560
2903	X	16	380	380	7.3	5.0	210	37	160
2904	X	15	410	410	6.8	4.2	170	30	140
2905 ¹	X	17	313	313	6.0	4.6	360	63	300
2906	X	15	390	380	9.0	5.0	220 / 270	38	160
2907 ¹	X	17	370	370	5.25	5.0	213	37	160
2908 ¹	X	16	295	295	7.25	4.2	368	64	300
2910	X	17	400	390	7.5	6.9	150 / 260	26 / 45	160
2911	X	16	400	390	7.5	6.0	140 / 230	24 / 40	160
2912	X	15	420	420	10.8	5.7	180 / 300	31 / 52	160
2913	X	15	390	390	9.3	4.9	180 / 300	31 / 52	160
2914	X	18	330	330	8.1	5.5	650	114	580
2915	X	18	345	345	8.1	5.5	650	114	580
2917	X	21	345	335	7.25	8.4	700 / 900	112 / 158	650
2918	X	22	338	328	7.25	9.3	860 / 1000	151 / 175	650
2919	X	15	430	430	10.8	5.7	200 / 280	35 / 49	160
2920	X	14	430	430	8.0	3.7	190	33	160
2921	X	16	385	385	6.8	5.2	200	35	150
2922	X	14	360	360	6.1	3.3	140	25	120
2923	X	16	395	395	6.8	5.2	200	35	150
2924	X	19	340	340	8.1	6.2	790	138	580
2925	X	16	385	385	10.77	5.2	375	66	320
2926	X	16	392	392	10.77	5.2	375	66	320
2927	X	16	394	394	10.3	5.0	400	70	320
2928	X	16	410	410	6.8	5.3	200	35	150
2929	X	16	420	420	10.8	6.5	240 / 300	42 / 53	180
2930	X	14	475	465	9.8	4.2	162	28	140
2931	X	14	510	500	11.9	5.1	140	25	140
2932	X	14	480	470	11.2	4.8	140	25	140
2933	X	14	495	485	11.2	4.8	140	25	140
2934	X	14	510	500	10.0	4.3	160	28	140
2935	X	14	420	410	9.8	4.1	180	32	140
2936	X	15	420	410	10.0	4.8	220	39	170
2937	X	15	400	400	7.25	4.1	220	39	170
2938	X	18	400	390	7.5	7.7	205 / 290	36 / 51	160
2939	X	16	525	515	11.65	6.6	220	39	170
2940	X	14	380	370	8.6	3.7	190	33	140
2941	X	15	390	375	7.2	4.4	140	25	140
2942	X	15.5	380	365	6.58	4.2	160	28	140
2943	X	15	370	360	8.6	4.3	230	40	150
2944	X	15	395	385	8.0	4.4	190	33	165
2945	X	16	350	340	7.5	4.7	240	42	170
2947	X	16	340	340	5.8	4.4	170	30	150
2948	X	16	340	340	5.56	4.2	200	35	150
2949	X	17	370	355	7.1	5.6	216	38	160
2950	X	16	300	300	8.5	4.0	540	95	420
2951	X	15	290	290	8.5	3.5	440	77	420
2952	X	11	345	345	8.3	1.8	142	25	120
2953	X	16	285	285	8.5	4.1	540	95	420
2954	X	12	340	340	8.5	2.2	180	32	140
2955	X	13	350	350	10.0	3.0	200	35	140
2956	X	16	330	330	8.5	4.2	500	88	420
2959	X	16	310	310	8.5	4.0	540	95	440

1. When remaining stock is exhausted no further product will be available.

cont.

SPECIFICATIONS - COIL SPRINGS

COIL SPRINGS

Spring Number	X5K Steel	Bar Dia. mm	Free Height mm		Number Of Turns	Coil weight (kg)	Spring Rate		OE Spring Rate Lbs
			A	B			lbf / in	N / mm	
2960	X	15	300	300	8.5	3.5	440	77	410
2961	X	13	340	340	10.0	3.0	200	35	150
2962	X	16	320	320	8.5	4.0	540	95	440
2963	X	11.5	350	350	10.0	2.4	146	26	120
2965	X	11.5	365	365	10.0	2.4	146	26	120
2966	X	12	335	315	10.0	2.5	176	31	120
2967	X	12	325	325	9.0	2.4	176	31	120
2968	X	14	370	370	9.35	3.7	210	37	120
2969	X	12	360	360	9.5	2.5	170	30	150
2970	X	17	395	385	6.7	5.2	320	56	160
2971	X	17	405	395	6.66	4.5	320	56	160
2972	X	16	400	385	6.55	4.5	250	44	160
2972E	X	16	404	404	6.55	4.5	250	44	160
2973	X	16	415	400	6.55	4.5	250	44	160
2974	X	16	385	370	6.55	4.5	250	44	160
2974E	X	16	385	385	6.55	4.5	250	44	160
2975	X	16	425	410	7.45	5.0	220	39	160
2976	X	16	440	425	7.2	4.9	220	39	160
2977	X	20	370	370	7.6	7.1	730	128	650
2978	X	20.5	370	370	7.6	7.6	790	138.5	650
2979	X	20.5	375	375	7.6	7.6	790	138.5	650
2980	X	19	490	470	9.0	10.0	250	44	200
2981	X	21	480	460	9.0	12.3	300	53	200
2982	X	19	470	450	9.0	10.0	250	44	200
2983	X	20	480	455	9.0	11.1	300 / 400	44 / 70	200
2984	X	21	480	455	9.0	12.3	360 / 450	63 / 79	200
2985	X	21	480	460	7.0	9.8	470	82	200
2986	X	21	500	500	8.2	10.0	540	94.7	380
2987	X	22	500	500	8.1	11.0	610	107	380
2988	X	22.4	500	500	8.2	11.5	680	119	380
2990	X	18	370	370	8.9	6.3	530	93	440
2991	X	19	365	365	8.9	7.1	630	110	440
2992	X	17	355	345	7.15	5.8	240	42	190
2993	X	18	345	335	6.6	6.0	280	49	190
2994	X	21	335	325	7.25	8.4	700 / 900	123 / 158	600
2995	X	22	350	340	7.25	9.3	860 / 1000	151 / 175	600
2996	X	17.5	370	355	7.1	6.0	250	44	200
2997	X	18	360	360	8.72	5.5	800	140	700
2998	X	18	365	365	8.72	5.5	800	140	700
2999	X	18.5	365	365	8.72	5.8	840	147	700
3027	X	18.5	325	325	7.6	5.4	800	140	680
3028	X	17	430	420	8.5	6.1	330	58	250
3029	X	17	440	430	8.5	6.1	330	58	250
3030	X	20	435	425	7.5	9.0	270 / 330	47 / 58	190 / 280
3033	X	18	430	420	8.0	7.0	320	56	N/A
3034	X	21	505	485	9.0	12.4	300	52	N/A
3035	X	22	505	485	8.1	12.4	470	82	N/A
3036	X	18	455	445	8.0	7.0	320	56	N/A
3037	X	21	530	510	9.0	12.4	300	52	N/A
3038	X	22	530	510	8.1	12.4	470	82	N/A
3039	X	17	520	530	9.9	7.3	220	38.5	N/A
3040	X	19	505	515	8.3	9.2	250	44	N/A
3043	X	19	530	540	8.3	9.2	250	44	N/A
3046	X	15.5	490	490	9.81	5.4	200	35	N/A
3047	X	14.5	545	545	10.74	5.2	150	26	N/A
3048	X	18	350	350	8.72	5.5	800	140	N/A
3049	X	20	505	515	8.3	10.3	320	56	N/A
3051	X	17	545	555	9.9	7.3	220	38.5	N/A
3052	X	20	530	540	8.3	10.3	320	56	N/A

cont.

SPECIFICATIONS - COIL SPRINGS

COIL SPRINGS

Spring Number	X5K Steel	Bar Dia. mm	Free Height mm		Number Of Turns	Coil weight (kg)	Spring Rate		OE Spring Rate Lbs
			A	B			lbf / in	N / mm	
3056	X	16.5	360	360	9.75	4.7	590	103	580
3057	X	16.5	365	365	9.75	4.7	590	103	580
3058	X	16.5	370	370	9.75	4.7	590	103	580
3059 ¹	X	15.5	480	480	9.5	5.0	250	44	220
3060	XT	21	360	360	8.0	7.9	880	154	750
3061	X	16.5	450	450	9.85	6.2	250 / 300	44 / 52.5	N/A
3062	X	15.5	450	440	9.5	6.0	200	35	N/A
3063	X	16	450	440	9.5	6.5	225	39.4	N/A
3064	X	17	520	520	9.53	8.1	175 / 200	30.6 / 35	N/A
3065	X	19	515	515	9.3	10.0	270 / 330	47 / 58	N/A
3066	X	21	500	500	9.66	12.9	370 / 430	65 / 75	N/A
3067	X	22.4	470	460	8.3	13.4	350 / 650	61 / 114	N/A
3070 ¹	X	15.5	445	445	9.5	5.0	250	44	220
3071 ¹	X	15.5	485	485	9.5	5.0	250	44	220
3072 ¹	X	15.5	495	495	9.5	5.0	250	44	220
3073 ¹	X	15.5	460	460	9.5	5.0	250	44	220
3074	XT	20	385	385	8.0	7.0	750	131	750
3075	XT	21.5	580	580	11.95	13.1	520	91	N/A
3076	XT	21.5	605	605	11.95	13.1	520	91	N/A
3077 ¹	X	17	400	390	8.5	6.1	330	58	N/A
3078 ¹	XT	20	405	395	7.5	8.5	270 / 330	47 / 58	N/A
3079	X	17.5	310	310	7.75	4.7	690	121	N/A
3080	X	18	315	315	7.75	5.0	745	130	N/A
3085 ¹	X	15.5	515	510	10.75	6.0	250	44	220
3086 ¹	X	16	505	500	10.75	6.0	250	44	220
3087	X	15	420	420	8.5	4.5	220	38.5	220
3088	X	15.5	440	440	10.25	5.9	200 / 260	35 / 46	200
3089	X	16	445	445	10.25	6.3	240 / 300	42 / 53	200
3090	X	16.5	450	450	10.25	6.7	260 / 330	46 / 58	200
3091	X	15	435	435	8.18	4.1	220	38.5	220
3092	X	15.5	425	425	8.18	4.4	260	46	220
3093	X	16.5	430	430	8.13	5.0	320	56	220
3094	X	18	330	330	8.72	5.5	800	140	700
3095	X	16	445	445	8.5	5.8	180-260	32-46	210
3096	X	17	440	440	8.5	6.5	220-320	39-56	210
3097	X	18	440	440	8.5	7.4	280-380	49-67	210
3098	X	19	440	440	8.5	8.3	350-450	61-84	210
3099	X	16.75	390	390	10.0	5.4	500	87.5	440
3100	X	16.75	395	395	10.0	5.4	500	87.5	440
3101	X	16.75	400	400	10.0	5.4	500	87.5	440
3102	X	18.5	305	305	7.75	5.4	800	140	760
3103	X	18.5	310	310	7.75	5.4	800	140	760
3104	X	18.5	315	315	7.75	5.4	800	140	760
3105	X	18.5	320	320	7.75	5.4	800	140	760
3106	X	18	470	470	8.75	8.1	240-330	42-58	180-220
3107	X	18.5	490	490	8.75	8.6	260-350	46-61	180-220
3108	X	18	320	320	8.1	5.5	650	114	N/A
3109	X	18	340	340	8.1	5.5	650	114	N/A
3110	X	19.5	400	400	8.0	7.8	562-740	98-129	N/A
3111	X	20.3	410	410	8.0	8.5	700-840	122-147	N/A
3112	X	22.5	380	380	6.93	9.1	975	170	N/A
3113	X	17.5	435	435	9.85	7.0	300-400	52-70	N/A
3114	X	16.5	385	385	9.75	4.7	590	103	500
3115	X	18	325	325	7.75	5.0	745	130	N/A
3116	X	18	330	330	7.75	5.0	745	130	N/A
3132	X	18	325	325	7.75	5.1	730	128	680
2GQ02A	X	18	465	465	9.0	9.0	200	35	180
2GQ02AM	X	18	505	490	8.7	8.7	220 / 240	39 / 42	180
2GQ02B	X	19	445	445	9.0	10.0	250 / 280	44 / 49	180

1. When remaining stock is exhausted no further product will be available.

cont.

SPECIFICATIONS - COIL SPRINGS

COIL SPRINGS

Spring Number	X5K Steel	Bar Dia. mm	Free Height mm		Number Of Turns	Coil weight (kg)	Spring Rate		OE Spring Rate Lbs
			A	B			lbf / in	N / mm	
2GQ02C	X	18	480	465	9.0	9.0	200	35	180
2GQ02CM	X	17	485	470	9.0	7.9	170 / 190	30 / 33	180
2GQ02D	X	18	480	480	9.0	9.0	200	35	180
2GQ02G	X	19	475	460	9.0	10.0	220 / 350	39 / 61	180
2GQ02LP	X	19	475	445	9.0	10.0	250 / 280	44 / 49	180
2GQ02J	X	20	480	465	9.0	11.1	280 / 310	49 / 54	180

X5K MICRO-ALLOYED SPRING STEEL is a new generation high strength spring steel grade designed to withstand higher operating stresses with superior resistance to sag and improved toughness and corrosion fatigue properties. These properties are enhanced by additions of Silicon, Chromium, Vanadium Nickel along with lower Carbon than conventional spring steel grades.

SPECIFICATIONS - SHOCK ABSORBERS

NITROCHARGER SPORT

Part Number	Open Length (mm)	Closed Length (mm)	Type	UPPER MOUNT BUSH KIT		Type	LOWER MOUNT BUSH KIT	
				Original Kit	Bushes only Replacement		Original Kit	Bushes only Replacement
60000	443	298	P4203	SMP493	N/A	E4050-BS	110-110-122	110-110-122
60001	443	298	P4203	SMP493	SMP493	E4050-BS	110-110-122	110-110-122
60002	612	368	P4204	SMP493	SMP493	E4005	110-034-069 ¹	OMEB40
60003	612	368	P4204	SMP493	SMP493	E4005	110-034-069 ¹	OMEB40
60004	580	356	P4184	SMP569	N/A	E4005	SMP621	OMEB40
60005	580	356	P4184	SMP569	SMP569	E4005	SMP621	OMEB40
60006	600	373	E4005	SMP649	SMP649	E4005	SMP649	SMP649
60007	597	373	E4005	SMP649	SMP649	E4005	SMP649	SMP649
60008	524	319	P4184	SMP501	OMEB42	P4184	SMP501	OMEB42
60009	589	349	P4169	SMP474	OMEB13	E4005	110-034-070	OMEB36
60010	652	403	E4005	110-034-070	OMEB15	E4005	110-034-070	OMEB15
60011	657	403	E4005	110-034-070	OMEB15	E4005	110-034-070	OMEB15
60012 ¹	496	301	P4184	SMP345	OMEB42	P4184	SMP345	OMEB42
60013	496	301	P4184	SMP345	OMEB42	P4184	SMP345	OMEB42
60013L	555	322	P4184	SMP345	OMEB42	P4184	SMP345	OMEB42
60014 ¹	657	403	E4005	SMP363	OMEB36	E4005	SMP363	OMEB40
60015	657	403	E4005	SMP363	OMEB36	E4005	SMP363	OMEB40
60015L	716	426	E4005	SMP363	OMEB36	E4005	SMP363	OMEB40
60016	376	262	E4051-S	110-110-076	N/A	E4051-S	110-110-076	N/A
60017	559	350	E4001	110-043-071	OMEB14	E4063-S	110-110-100	N/A
60018	617	359	P4184	SMP501	OMEB42	P4184	SMP501	OMEB42
60018L	667	381	P4184	SMP501	OMEB42	P4184	SMP501	OMEB42
60019	582	354	P4158	SMP641	N/A	E4040-BS	110-110-076	N/A
60020	625	378	P4184	SMP501	OMEB42	E4005	110-034-070	OMEB36
60020L	673	378	P4184	SMP501	OMEB42	E4005	110-034-070	OMEB36
60021	325	215	P4169	SMP474	OMEB13	E4026-S	110-A42-074	OMEB10
60022	363	239	P4205	SMP670	OMEB13	E4050	110-A42-126	110-A42-126
60023	624	380	E4005	-	OMEB15	E4005BS	110-034-080	-
60024	587	368	E4005-S	110-110-066	N/A	E4005-T	110-110-067	N/A
60024L	627	388	E4005-S	110-110-066	N/A	E4005-T	110-110-067	N/A
60025	587	368	E4005-S	110-110-066	N/A	E4005-BS	110-110-066	110-110-066
60025L	627	388	E4005-S	110-110-066	N/A	E4005-BS	110-110-066	N/A
60026	593	368	E4005-S	110-110-066	N/A	E4005-BS	110-110-066	110-110-066
60027	545	338	P4169	SMP474	OMEB13	E4005	110-034-070	OMEB15
60028	545	338	P4169	SMP474	OMEB13	E4005	110-034-070	OMEB15
60029 ¹	615	368	P4204	SMP493	N/A	E4005	110-034-069 ¹	OMEB40
60030 ¹	615	368	P4204	SMP493	N/A	E4005	110-034-069 ¹	OMEB40
60031	385	250	P	SMP675	OMEB13	E4026-S	110-A42-074	OMEB10
60032	597	365	E4001	*110-034-071	OMEB14	E4001	110-034-071	OMEB14
60033	581	354	P4158	SMP641	N/A	E4051-BS	110-110-076	N/A
60034	311	208	P4205	SMP474	OMEB13	E4026-S	110-A42-074	OMEB10
60035	560	345	E4001	SMP516	OMEB14	E4001	SMP511	OMEB14
60036	559	339	E4001	SMP516	OMEB14	E4001	SMP511	OMEB14
60037	553	329	P4184	SMP374	OMEB42	P4184	SMP374	OMEB42
60037L	593	349	P4184	SMP374	OMEB42	P4184	SMP374	OMEB42
60038	560	346	E4005	110-034-069 ¹	OMEB40	P4184	SMP683	SMP683
60039	560	346	E4005	110-034-069 ¹	OMEB40	P4184	SMP683	SMP683
60039L	600	366	E4005	110-034-069 ¹	OMEB40	P4184	SMP683	N/A
60040	345	225	P4169	SMP474	OMEB13	E4026-S	110-A42-074	OMEB10
60041	478	304	P4169	SMP474	OMEB13	E4001	110-034-077 ¹	OMEB17
60042	352	232	P4169	SMP474	OMEB13	E4005-S	110-034-072	OMEB17
60043	660	397	E4005	110-034-070	OMEB15	E4005	110-034-070	OMEB15
60044	640	390	E4005	110-034-070	OMEB15	E4005	110-034-070	OMEB15
60045	642	382	E - TB	N/A	N/A	E - S	N/A	N/A
60046	565	334	P4169	SMP476	N/A	E4026-TB	110-110-088	N/A

Note: Bush kits with part numbers starting with SMP indicate the kits have the urethane bush, mounting nut & washers. cont.

*Also supplied with SMP495 spacer kit

1. When remaining stock is exhausted no further product will be available.

See page 165 for legend of mount types.

SPECIFICATIONS - SHOCK ABSORBERS

NITROCHARGER SPORT

Part Number	Open Length (mm)	Closed Length (mm)	Type	UPPER MOUNT BUSH KIT		Type	LOWER MOUNT BUSH KIT	
				Original Kit	Bushes only Replacement		Original Kit	Bushes only Replacement
60047	565	334	P4169	SMP476	N/A	E4026-TB	110-110-088	N/A
60047L	678	392	P4169	SMP476	N/A	E4026-TB	110-110-088	N/A
60048	559	338	E4026-TB	110-110-089	N/A	E4026-S	110-A42-102	N/A
60049	559	338	E4026-TB	110-110-089	N/A	E4026-S	110-A42-102	N/A
60049L	622	366	E4026-TB	110-110-089	N/A	E4026-S	110-A42-102	N/A
60050	659	389	E4001	110-110-071	OMEB14	E4001	110-110-071	OMEB14
60051	339	224	P4169	SMP670	OMEB13	E4026-T	110-110-078	110034078
60052	565	344	P4169	SMP476	N/A	E4026-T	110-110-088	110-110-088
60052L	678	392	P4169	SMP476	N/A	E4026-TB	110-110-088	N/A
60053	559	338	E4026-T	110-110-089	110-110-089	E4026-S	110-A42-102	OMEB10
60053L	622	366	E4026-TB	110-110-089	N/A	E4026-S	110-A42-102	OMEB10
60054	644	384	E4005	SMP517 ¹	OMEB36	P4169	SMP474	OMEB13
60055	496	301	P4184	SMP345	OMEB42	P4184	SMP345	OMEB42
60056	503	312	E4001	110-110-071	OMEB14	E4005-S	N/A	OMEB17
60057	559	339	E4001	SMP516	OMEB14	E4001	SMP516	OMEB14
60058	619	369	E4001	110-110-071	OMEB14	E4001	110-110-071	OMEB14
60059	523	329	E4001	110-034-071	OMEB14	E4005-S	110-034-072	OMEB17
60060	528	318	P4205	SMP474	OMEB13	E4050	SMP650 ¹	OMEB15
60061	485	294	P4169	SMP474	OMEB13	E4026-S	110-A42-074	OMEB10
60062	587	357	E4005	110-034-070	OMEB15	E4005	110-034-070	OMEB15
60063	588	348	P4169	SMP474	OMEB13	E4005	110-034-070	OMEB36
60064	594	360	E4005	110-034-071	OMEB14	E4005	110-034-071	OMEB14
60065	581	356	E4005	110-034-070	OMEB15	E4005	110-034-070	OMEB15
60066	580	348	P4184	SMP658	OMEB42	E	N/A	N/A
60066L	693	404	P4184	SMP658	OMEB42	E	N/A	N/A
60066M	646	382	P4184	SMP658	OMEB42	E	N/A	N/A
60067	619	368	E-TB	N/A	N/A	E	N/A	N/A
60067L	706	422	E-TB	N/A	N/A	E	N/A	N/A
60068	509	314	P4169	SMP474	OMEB13	E4005	110-034-070	OMEB15
60069	576	362	E4057-S	110-110-085	N/A	E4005-S	110-110-086 ¹	N/A
60070	617	359	P4184	SMP501	OMEB42	P4184	SMP501	OMEB42
60070L	667	381	P4184	SMP501	OMEB42	P4184	SMP501	OMEB42
60071	625	378	P4184	SMP501	OMEB42	E4005	110-034-070	OMEB36
60071L	673	387	P4184	SMP501	OMEB42	E4005	110-034-070	OMEB36
60072	383	254	P4169	SMP474	OMEB13	E4005-S	110-034-072	OMEB17
60073	549	334	P4169	SMP474	OMEB13	E4005	110-034-070	OMEB36
60074	517	333	E4005-S	110-034-072	OMEB17	E4005	110-034-070	OMEB15
60075	523	329	E4001	110-034-071	OMEB14	E4005-S	110-034-072	OMEB17
60076	523	329	E4001	110-034-071	OMEB14	E4005-S	110-034-072	OMEB17
60077	583	354	P4205	SMP474	OMEB13	E4005-S	110-034-070	OMEB15
60078	583	354	P4205	SMP474	OMEB13	E4005-S	110-034-070	OMEB15
60080	603	368	P4184	SMP569	SMP569	E4005	SMP621	OMEB40
60081	603	368	P4184	SMP569	SMP569	E4005	SMP621	OMEB40
60082	602	368	N/A	N/A	N/A	N/A	N/A	N/A
60083	602	368	N/A	N/A	N/A	N/A	N/A	N/A
60084	560	350	P	SMP705	N/A	E	110-110-126	N/A
60085 ¹	560	350	P	SMP705	N/A	E	110-110-126	N/A
60086	603	368	P4184	SMP569	SMP569	E4005	SMP621	OMEB40
60087	535	330	P4170	SMP312	N/A	E4026-T	SMP487	N/A
60088	580	355	E4057-S	110-110-085	N/A	E4001	110-034-020 ¹	OMEB10
60089	569	338	E-4032-S	110-034-070	N/A	P4169	SMP474	OMEB13
60090	508	308	E4005	110-034-070	OMEB15	P4169	SMP474	OMEB13
60091	599	360	P4205	SMP474	OMEB13	E4026-S	110-A42-074	N/A
60092	565	345	P14969	SMP476	OMEB13	E4026-T	110-110-038	N/A
60093	562	343	E4003	110-034-076	N/A	E4026-S	110-034-056	OMEB10
60094	469	291	P4184	SMP345	OMEB42	P4184	SMP345	OMEB42

Note: Bush kits with part numbers starting with SMP indicate the kits have the urethane bush, mounting nut & washers. cont.

1. When remaining stock is exhausted no further product will be available.

See page 165 for legend of mount types.

SPECIFICATIONS - SHOCK ABSORBERS

NITROCHARGER SPORT

Part Number	Open Length (mm)	Closed Length (mm)	Type	UPPER MOUNT BUSH KIT		Type	LOWER MOUNT BUSH KIT	
				Original Kit	Bushes only Replacement		Original Kit	Bushes only Replacement
60095	442	284	P4169	SMP474	OMEB13	E4005	110-034-070	OMEB15
60096	531	342	E4005	110-064-070	OMEB15	E4005	110-064-070	OMEB15
60097	493	315	E4001	110-034-071	OMEB14	E4001	110-034-071	OMEB14
60098	625	365	P4169	SMP476	OMEB13	E4026-S	110-A42-102	OMEB10
60099	509	329	E4001	110-034-065 ¹	OMEB14	E4026-S	110-A42-102	OMEB10
60100	650	385	P	SMP493	N/A	E	110-110-102 ¹	N/A
60101	624	380	E4005	110-110-113	OMEB15	E4005-BS	110-A42-126	N/A
60102	624	380	E4005	110-110-113	OMEB15	E4005-BS	110-A42-126	N/A
60109	685	420	E4005	110-034-070	OMEB15	E4005	110-034-070	OMEB15
60110	559	350	E4001	110-034-071	OMEB14	E4063S	110-110-100	N/A
60111	665	400	E4005	110-034-070	OMEB15	E4005	110-034-070	OMEB15
60112	580	356	P4184	SMP569	N/A	E4005	SMP621	OMEB40
60113	600	365	E	110-A42-139	N/A	P	SMP706	N/A
60114	610	365	P	SMP706	N/A	E	110-110-077	N/A
60116	555	340	E4005	110-034-071	OMEB14	E4005	110-034-071	OMEB14
60117	555	340	E4005	110-034-071	OMEB14	E4005	110-034-071	OMEB14
60121	620	370	P	SMP493	N/A	E	110-110-103	N/A
60122	785	460	E	SMP657	N/A	E	110-A42-124 ¹	N/A
60123	560	340	P4204	SMP493	-	E4051-S	110-110-103	110-110-103
60124	585	415	P	SMP712	N/A	CLEVIS	N/A	N/A
60125	585	415	P	SMP712	N/A	CLEVIS	N/A	N/A
60126	550	385	P	SMP725	N/A	CLEVIS	N/A	N/A
60127	550	385	P	SMP725	N/A	CLEVIS	N/A	N/A
60130	595	363	P	SMP474	N/A	E	110-110-103	N/A
60131	595	363	P	SMP474	N/A	E	110-110-103	N/A
60132	627	390		SMP649	N/A		SMP649	N/A
60133	627	390		SMP649	N/A		SMP649	N/A
60134	617	372		110-034-071	N/A		110-034-071	N/A
60135	647	392		110-034-071	N/A		110-034-071	N/A
60136	608	379		110-034-071	N/A		110-110-115	N/A
60137	608	379		110-034-071	N/A		110-110-115	N/A
60138	553	340		110-034-071	N/A		110-034-071	N/A
60139	553	340		110-034-071	N/A		110-034-071	N/A
60140	553	340		110-034-071	N/A		110-034-071	N/A
60141	583	354		SMP474	OMEB13		SMP621	OMEB40
60142	583	354		SMP474	OMEB13		SMP621	OMEB40
60144	586	352		Use OE	Use OE		110-110-128	N/A
60145	586	352		Use OE	Use OE		110-110-128	N/A
61012	496	301	P4184	SMP345	OMEB42	P4184	SMP345	OMEB42
61014	657	403	E4005	SMP363	OMEB36	E4005	SMP363	OMEB40
61029	615	368	P4204	SMP718	N/A	E4005	110-034-069 ¹	OMEB40
61030	615	368	P4204	SMP718	N/A	E4005	110-034-069 ¹	OMEB40
90000	543	413	P	SMP671	SMP671	E4050-S	110-110-122	110-110-122
90001	404	273	P	N/A	N/A	N/A	110-110-100	110-110-100
90002	548	413	P	SMP671	SMP671	E4050-S	110-110-122	110-110-122
90003	390	287	P	SMP633	N/A	E4063-BS	110-110-100	110-110-100
90003 (02/11 on)	390	287	P	SMP633	N/A	E4063-BS	110-110-112	110-110-112
90004	473	340	P	SMP673	N/A	E4050-B	110-110-122	110-110-122
90005 ¹	613	432	P4214	OE	OE	E4066	110-110-110	110-110-110
90006	474	330	N/A	Use OE Bushes	N/A	E4055BS	110-110-075	N/A
90006 (10/15 on)	474	330	N/A	Use OE Bushes	N/A	E4055BS	110-110-125	N/A
90007	474	330	P	Use OE Bushes	N/A	E4055BS	110-110-125	N/A
90008	426	306	P	N/A	N/A	E4055BS	110-110-125	N/A
90009	319	207	P	Use OE Bushes	N/A	N/A	N/A	N/A
90010	543	413	P	Use OE Bushes	N/A	E4050-S	110-110-112	110-110-112
90010 (09/13 On)	543	413	P	Use OE Bushes	N/A	E4050-S	110-110-115	110-110-115

Note: Bush kits with part numbers starting with SMP indicate the kits have the urethane bush, mounting nut & washers. cont.

1. When remaining stock is exhausted no further product will be available.

See page 165 for legend of mount types.

SPECIFICATIONS - SHOCK ABSORBERS

NITROCHARGER SPORT

Part Number Nitrocharger Sport	Open Length (mm)	Closed Length (mm)	Type	UPPER MOUNT BUSH KIT		Type	LOWER MOUNT BUSH KIT	
				Original Kit	Bushes only Replacement		Original Kit	Bushes only Replacement
90011	548	413	P	SMP626	SMP626	E4050-S	110-110-122	110-110-122
90012	615	485	P	SMP698	N/A	N/A	N/A	N/A
90013	615	485	P	SMP698	N/A	N/A	N/A	N/A
90014	458	297	P	SMP672	OE	E	110-110-117	N/A
90015	458	297	P	SMP672	OE	E	110-110-117	N/A
90016	543	413	P	Use OE Bushes	N/A	E4050-S	110-110-112	110-110-112
90016 (09/13 On)	543	413	P	Use OE Bushes	N/A	E4050-S	110-110-112	110-110-115
90017	613	432	P4124	OE	OE	E4066	110-110-110	N/A
90018	610	455	P	SMP710	N/A	E	110-110-110	N/A
90019	505	368	P	OE	OE	E	N/A	110-110-129
90020	505	368	P	OE	OE	E	N/A	110-110-129
90021	543	413	P	SMP671	SMP671	E4050-S	110-110-122	110-110-122
90022	495	350	P	Use OE Bushes	N/A	N/A	110-110-122	N/A
90023	495	350	P	Use OE Bushes	N/A	N/A	110-110-122	N/A
90026	815	665	P	SMP719	N/A	CLEVIS	N/A	N/A
90028	560	430		N/A	N/A		110-110-115	N/A
90029	560	430		N/A	N/A		110-110-115	N/A
90031	425	305		SMP734	N/A		110-110-125	N/A
90032	392	294		USE OE	N/A		110-110-115	N/A
90033	425	305		SMP734	N/S		110-110-125	N/A
91005	613	432	P4124	OE	OE	E4066	110-110-110	N/A

Note: Bush kits with part numbers starting with SMP indicate the kits have the urethane bush, mounting nut & washers. See page 165 for legend of mount types.

SPECIFICATIONS - SHOCK ABSORBERS

NITROCHARGERS

Part Number Nitrocharger	Open Length (mm)	Closed Length (mm)	Type	UPPER MOUNT BUSH KIT		Type	LOWER MOUNT BUSH KIT	
				Original Kit	Bushes only Replacement		Original Kit	Bushes only Replacement
N15 ¹ /N15C ¹	517	327	E4005-S	110-034-072	N/A	E4005	110-034-070	OMEB36
N16	477	352	P4184	SMP374	OMEB42	E4078-T	SMP487	110034078
N17	632	382	E4026-T	SMP488	110034078	E4026-S	110-034-074 ¹	N/A
N18 ¹	340	225	P4169	SMP474	OMEB13	E4026-S	110-A42-074	OMEB10
N19/N19C ¹	492	292	P4184	SMP345	OMEB42	P4184	SMP345	OMEB42
N21 ¹	492	292	P4184	SMP345	OMEB42	P4184	SMP345	OMEB42
N22F ¹	656	396	E4005	SMP363	OMEB36	E4005	SMP363	OMEB40
N23F ¹	492	292	P4184	SMP345	OMEB42	P4184	SMP345	OMEB42
N25	642	377	E4005	SMP517 ¹	OMEB36	P4169	SMP474	OMEB13
N26F ¹	381	245	P4169	SMP474	OMEB13	E4026-S	N/A	OMEB10
N27 ¹	560	340	E4005	110-034-069 ¹	OMEB40	P4184	SMP683	SMP683
N28 ¹	504	309	P4169	SMP474	OMEB13	E4005	SMP343 ¹	OMEB36
N29/N29C ¹	656	396	E4005	SMP363	OMEB36	E4005	SMP363	OMEB40
N30 ¹	618	368	E4001	110-034-065 ¹	OMEB14	E4001	110-034-065 ¹	OMEB14
N30E	659	389	E4001	*110-034-065 ¹	OMEB14	E4001	110-034-065 ¹	OMEB14
N31S ¹	501	318	N/A	N/A	N/A	N/A	N/A	N/A
N32	500	315	P4169	SMP474	OMEB13	E4026-S	N/A	OMEB10
N33	625	365	P4169	SMP476	OMEB13	E4026-S	110-034-056	OMEB10
N34 ¹	509	329	E4001	110-034-065 ¹	OMEB14	E4026-S	110-034-056	OMEB10
N35 ¹ /N35C ¹	568	348	P4169	SMP476	N/A	E4026-T	110-110-088	110-110-088
N36/N36C ¹	562	342	E4026-T	110-110-089	110-110-089	E4026-S	110-034-056	OMEB10
N37	591	366	E4040-S	110-110-054 ¹	N/A	E4040-S	110-110-054 ¹	N/A
N38S	473	339	P	N/A	N/A	E-B	N/A	N/A
N39 ¹ /N39C ¹	562	342	P4169	SMP476	SMP476	E4026-T	110-110-088	110-110-088
N40 ¹ /N40C ¹	556	336	E4003	110-034-076	N/A	E4026-S	110-034-056	OMEB10
N41	499	309	E4001	110-034-065 ¹	OMEB14	E4001	110-034-065 ¹	OMEB14
N42	594	359	E4001	110-034-065 ¹	OMEB14	E4001	110-034-065 ¹	OMEB14
N43	485	295	P4169	SMP474	OMEB13	E4001	110-034-065 ¹	OMEB14
N44	560	340	E4005	110-034-069 ¹	OMEB40	P4184	SMP683	SMP683
N45F ¹	554	324	P4184	SMP343 ¹	OMEB42	P4184	SMP343 ¹	OMEB42
N46 ¹	560	340	E4005	110-034-069 ¹	OMEB40	P4184	SMP683	SMP683
N47	406	251	P4169	SMP474	OMEB13	P4169	SMP474	OMEB13
N48	560	335	E4001	110-034-065 ¹	OMEB14	P4169	SMP474	OMEB13
N49	446	271	P4169	SMP474	OMEB13	P4169	SMP474	OMEB13
N50	584	349	P4169	SMP474	OMEB13	E4005	110-034-070	OMEB36
N51 ¹	365	235	P4169	SMP474	OMEB13	E4026-BS	110-034-181	110-034-181
N52 ¹ /N52F ¹	425	265	P4161	SMP334 ¹	N/A	E4026-S	110-A42-071 ¹	OMEB10
N53 ¹ /N53C ¹	628	378	E4040-B	110-004-040 ¹	N/A	E4026-S	110-034-181	110-034-181
N54 ¹	554	339	E4001	*110-034-065 ¹	OMEB14	E4001	110-034-065 ¹	OMEB14
N55 ¹	585	345	P4161	SMP334 ¹	N/A	E4026-S	110-A42-071 ¹	OMEB10
N56 ¹	554	339	E4001	*SMP516	OMEB14	E4001	SMP516	OMEB14
N57G ¹	340	225	P4169	SMP474	OMEB13	E4026-S	N/A	OMEB10
N58 ¹	325	215	P4169	SMP474	OMEB13	E4026-S	N/A	OMEB10
N59	559	339	E4001	*SMP516	OMEB14	E4001	SMP516	OMEB14
N60G ¹	340	225	P4169	SMP474	OMEB13	E4026-T	110-110-078	110034078
N61/N61C ¹	607	367	E4005-S	SMP363	OMEB17	E4026-S	110-034-056	OMEB10
N62G ¹	507	317	E4001	110-034-065 ¹	OMEB14	E4005-S	110-034-077 ¹	OMEB17
N63G ¹	478	299	P4169	SMP474	OMEB13	E4005-S	110-034-077 ¹	OMEB17
N64 ¹ /N64C ¹	478	299	P4169	SMP474	OMEB13	E4005-S	110-034-077 ¹	OMEB17
N65	385	245	P4169	SMP474	OMEB13	E4026-S	110-A42-074	OMEB10
N66 ¹ /N66C ¹	568	335	P4169	SMP476	N/A	E4026-TB	110-110-088	N/A
N67 ¹	562	339	E4026-TB	110-110-089	N/A	E4026-S	110-034-056	OMEB10
N68 ¹	640	384	E4005	110-034-070	OMEB15	E4005	110-034-070	OMEB15
N68E ¹	660	394	E4005	110-034-070	OMEB15	E4005	110-034-070	OMEB15
N69	470	290	E4005	110-034-070	OMEB36	P4184	SMP343 ¹	OMEB42

Note: Bush kits with part numbers starting with SMP indicate the kits have the urethane bush, mounting nut & washers. cont.

*Spacer Kit SMP511 also supplied.

1. When remaining stock is exhausted no further product will be available.

See page 165 for legend of mount types.

SPECIFICATIONS - SHOCK ABSORBERS

NITROCHARGERS

Part Number Nitrocharger	Open Length (mm)	Closed Length (mm)	Type	UPPER MOUNT BUSH KIT		Type	LOWER MOUNT BUSH KIT	
				Original Kit	Bushes only Replacement		Original Kit	Bushes only Replacement
N70 ¹	614	354	P4184	SMP403 ¹	OMEB42	P4184	SMP403 ¹	OMEB42
N71E ¹	620	370	P4184	SMP403 ¹	OMEB42	E4005	110-034-070	OMEB36
N72F ¹	548	329	P4169	SMP474	OMEB13	E4005	110-034-070	OMEB36
N73	614	354	P4184	SMP501	OMEB42	P4184	SMP501	OMEB42
N74E	620	370	P4184	SMP501	OMEB42	E4005	110-034-070	OMEB36
N75 ¹	640	390	E4005	110-034-070	OMEB15	E4005	110-034-070	OMEB15
N75E ¹ /N75F ¹	652	397	E4005	110-034-070	OMEB15	E4005	110-034-070	OMEB15
N76	685	408	E4005	110-034-070	OMEB15	E4005	110-034-070	OMEB15
N77 ¹	570	340	E4032-S	110-110-077	N/A	P4169	SMP474	OMEB13
N78	447	287	E4005	110-034-070	OMEB15	E4005	110-034-070	OMEB15
N79 ¹	507	307	E4005	110-034-070	OMEB36	P4169	SMP474	OMEB13
N80 ¹	352	232	P4169	SMP474	OMEB13	E4005-S	110-034-072	OMEB17
N81	499	309	E4001	110-034-065 ¹	OMEB14	E4001	110-034-065 ¹	OMEB14
N83 ¹	345	225	P4169	SMP474	OMEB13	E4026-S	SMP381	OMEB10
N84 ¹	485	295	P4169	SMP474	OMEB13	E4026-S	N/A	OMEB10
N85 ¹	587	357	E4005	110-034-070	OMEB15	E4005	110-034-070	OMEB15
N86/N86C ¹	539	329	P4169	SMP474	OMEB13	E4005	110-034-070	OMEB15
N87 ¹	352	232	P4169	SMP474	OMEB13	E4005-S	110-034-072	OMEB17
N88 ¹	589	349	P4169	SMP474	OMEB13	E4005	110-034-070	OMEB36
N89	594	359	E4001	**110-034-065 ¹	OMEB14	E4001	110-034-065 ¹	OMEB14
N90 ¹	582	357	E4005	110-034-070	OMEB15	E4005	110-034-070	OMEB15
N91S ¹	470	335	P-	SMP415	N/A	E4050-B	110-110-122	110-110-122
N91SC ¹	470	335	P-	SMP415	N/A	E4050-B	110-110-122	110-110-122
N92 ¹	589	349	P4169	SMP474	OMEB13	E4005	110-034-070	OMEB36
N93 ¹	485	295	P4169	SMP474	OMEB13	E4026-S	N/A	OMEB10
N94 ¹	587	357	E4005	110-034-070	OMEB15	E4005	110-034-070	OMEB15
N95 ¹	599	359	E4001	**110-034-065 ¹	OMEB14	E4001	110-034-065 ¹	OMEB14
N96	431	261	P4169	SMP474	OMEB13	P4169	SMP474	OMEB13
N97	545	325	E4001	110-034-065 ¹	OMEB14	P4169	SMP474	OMEB13
N98 ¹	389	249	P4169	SMP474	OMEB13	E4005-S	110-034-072	OMEB17
N100 ¹	440	290	P4203	SMP493	N/A	E4050-BS	110-110-122	110-110-122
N101/N101C ¹	610	360	P4204	SMP493	SMP493	E4005	110-034-069 ¹	OMEB40
N102	482	302	P4169	SMP474	OMEB13	E4050-BS	110-110-122	N/A
N103S	504	318	P-	N/A	N/A	N/A	N/A	N/A
N104/N104C ¹	641	391	E4040-S	110-110-054 ¹	N/A	E4055-S	110-110-069 ¹	N/A
N105	508	318	P4169	SMP474	OMEB13	E4026-S	110-004-074 ¹	OMEB10
N106 ¹ /N106C ¹	537	317	P4184	SMP501	OMEB42	P4184	SMP501	OMEB42
N107 ¹ /N107C ¹	608	373	E4005-S	110-110-066	N/A	E4005-T	110-110-067	N/A
N108 ¹ /N108C ¹	593	363	E4005-S	110-110-066	N/A	E4005-BS	110-110-066	110-110-066
N109S ¹	472	327	N/A	Use OE Bushes	N/A	E4055BS	110-110-075	N/A
N110 ¹	575	350	P4158	SMP641	N/A	E4040-BS	110-110-076	N/A
N111	548	328	P4170	SMP312	N/A	E4026-S	SMP487	N/A
N112 ¹	449	279	P4169	SMP474	OMEB13	E4005	110-034-070	OMEB15
N113 ¹	537	337	E4005	110-034-070	OMEB15	E4005	110-034-070	OMEB15
N114 ¹	475	285	P4184	SMP345	OMEB42	P4184	SMP345	OMEB42
N115 ¹	554	324	P4184	SMP374	OMEB42	P4184	SMP374	OMEB42
N116	527	327	E4001	110-034-065 ¹	OMEB14	E4005-S	110-034-072	OMEB17
N117	578	358	E4057-S	110-110-085	N/A	E4001-T	110-034-020 ¹	OMEB10
N118	532	322	P4169	SMP474	OMEB13	E4005	110-034-080	OMEB11
N119S ¹	596	395	N/A	SMP483 ¹	SMP483 ¹	N/A	N/A	N/A
NC120 ¹	609	402	N/A	110-039-058 ¹	110039058 ¹	N/A	N/A	N/A
N121S ¹	576	389	N/A	SMP483 ¹	SMP483 ¹	N/A	N/A	N/A
NC122 ¹	589	402	N/A	110-039-058 ¹	110039058 ¹	N/A	N/A	N/A
N123S ¹	596	395	N/A	SMP483 ¹	SMP483 ¹	N/A	N/A	N/A
N124S ¹	576	389	N/A	SMP483 ¹	SMP483 ¹	N/A	N/A	N/A

Note: Bush kits with part numbers starting with SMP indicate the kits have the urethane bush, mounting nut & washers. cont.

** Spacer Kit SMP495 supplied

1. When remaining stock is exhausted no further product will be available.

See page 165 for legend of mount types.

SPECIFICATIONS - SHOCK ABSORBERS

NITROCHARGERS

Part Number Nitrocharger	Open Length (mm)	Closed Length (mm)	Type	UPPER MOUNT BUSH KIT		Type	LOWER MOUNT BUSH KIT	
				Original Kit	Bushes only Replacement		Original Kit	Bushes only Replacement
N125S ¹	411	289	P	SMP363	SMP363	N/A	N/A	N/A
N126S ¹	411	289	P	SMP363	SMP363	N/A	N/A	N/A
N127S ¹	601	385	P	SMP354 ¹	SMP354 ¹	E-BS	N/A	N/A
N128 ¹	358	238	P4205	SMP474	OMEB13	E4026-T	SMP489 ¹	N/A
N129S ¹	472	327	P	Use OE Bushes	N/A	E4055-BS	110-110-075	110-110-075
N129S ¹ (10/15 on)	472	327	P	Use OE Bushes	N/A	E4055-BS	110-110-125	110-110-125
NS130 ¹	333	201	P	SMP725	SMP725	N/A	N/A	N/A
NS131 ¹	333	201	P	SMP725	SMP725	N/A	N/A	N/A
N132 ¹	573	359	E4057-S	110-110-085	N/A	E4005-S	110-110-086 ¹	N/A
N133	443	287	P4203	SMP493	SMP493	E4050-BS	110-110-122	110-110-122
N134 ¹	559	349	E4057-S	110-110-085	N/A	E4005-S	110-110-086 ¹	N/A
N135S ¹ /N136S ¹	602	393	P	SMP483 ¹	SMP483 ¹	N/A	N/A	N/A
NC138 ¹	609	400	P	SMP546 ¹	N/A	-	-	-
N139S ¹	543	405	P	SMP633/626	N/A	E4050-S	110-110-122	110-110-122
N140S	543	405	P	SMP633/626	N/A	E4050-S	110-110-122	110-110-122
N141	577	353	P4184	SMP569	N/A	E4005	SMP621	OMEB40
N142 ¹	577	353	P4184	SMP569	N/A	E4005	SMP621	OMEB40
N143S ¹	590	408	P	-	N/A	-	-	N/A
N144S ¹	590	408	P	-	N/A	-	-	N/A
N145S	593	405	N/A	SMP622	N/A	N/A	N/A	N/A
NC145 ¹	651	439	P	SMP625 ¹	N/A	-	-	N/A
N146 ¹	655	379	P	SMP641	N/A	E4055-BS	110-110-093 ¹	N/A
N146S	593	405	N/A	SMP622	N/A	N/A	N/A	N/A
N147S	476	362	P	SMP640	N/A	E4050-S	110-110-122	110-110-122
N148S	476	362	P	SMP640	N/A	E4050-S	110-110-122	110-110-122
N149	504	313	E4051-BS	110-110-092 ¹	N/A	E4051-BS	110-110-092 ¹	N/A
N150 ¹	388	242	P4205	SMP474	OMEB13	E4026-S	110-A42-074	OMEB10
N151 ¹	308	202	P4205	SMP474	OMEB13	E4026-S	110-A42-074	OMEB10
N152 ¹	576	345	P4158	SMP641	N/A	E4051-BS	110-110-076	N/A
N153 ¹	528	312	P4205	SMP474	OMEB13	E4026-S	110-034-074 ¹	OMEB10
N154 ¹	562	336	E4001	110-034-065 ¹	OMEB14	E4001	110-034-065 ¹	OMEB14
N155 ¹	568	332	P4205	SMP474	OMEB13	E4001	110-034-065 ¹	OMEB14
N156S ¹	365	530	-	Nut only	OEM	N/A	OEM	OEM
N157S ¹	365	530	-	Nut only	OEM	N/A	OEM	OEM
N158S ¹	405	610	-	Nut only	OEM	N/A	OEM	OEM
N159S ¹	405	610	-	Nut only	OEM	N/A	OEM	OEM
NC160 ¹	601	403	P	SMP546 ¹	SMP546 ¹	N/A	N/A	N/A
NC161 ¹	572	386	P	SMP625 ¹ & 633	SMP625 ¹ & 633	N/A	N/A	N/A
N162 ¹	348	222	P4205	SMP474	OMEB13	E4026-S	110-A42-074	OMEB10
NC163 ¹	617	386	P	SMP625 ¹ & 633	SMP625 ¹ & 633	N/A	N/A	N/A
N164 ¹	527	317	P4184	SMP501	OMEB42	P4184	SMP501	OMEB42
N165 ¹	657	397	E4005	110-034-070	OMEB15	E4005	110-034-070	OMEB15
N166S	543	411	P	SMP633 & 626	SMP633 & 626	E4050-S	110-110-122	110-110-122
N167S	543	411	P	SMP633 & 626	SMP633 & 626	E4050-S	110-110-122	110-110-122
N168	600	370	E4005	SMP649	SMP649	E4005	SMP649	SMP649
N169 ¹	600	370	E4005	SMP649	SMP649	E4005	SMP649	SMP649
N170 ¹	348	322	P4205	SMP474	OMEB13	E4026-S	110-A42-074	OMEB10
N171 ¹	532	316	P4205	SMP474	OMEB13	E4005	SMP650 ¹	OMEB15
N172 ¹	532	316	P4205	SMP474	OMEB13	E4005	SMP650 ¹	OMEB15
N173S ¹	481	301	P	N/A	N/A	-	N/A	N/A
N174 ¹	597	341	P4180	SMP343 ¹	SMP343 ¹	P4180	SMP343 ¹	SMP343 ¹
N175 ¹	603	363	E4005	110-034-063 ¹	OMEB36	P4180	SMP343 ¹	SMP343 ¹
N176	535	319	E4055-S	110-110-066	N/A	P4180	SMP343 ¹	SMP343 ¹
N177	485	299	E4055-S	110-110-066	N/A	P4180	SMP343 ¹	SMP343 ¹
N178	600	364	E4005	110-034-082	110-034-082	E4005-S	110-A42-124 ¹	OMEB11
N179	790	456	E4005	110-034-083 ¹	110-034-083 ¹	E4005-S	110-A42-124 ¹	OMEB11

Note: Bush kits with part numbers starting with SMP indicate the kits have the urethane bush, mounting nut & washers. cont.

1. When remaining stock is exhausted no further product will be available.

See page 165 for legend of mount types.

SPECIFICATIONS - SHOCK ABSORBERS

NITROCHARGERS

Part Number Nitrocharger	Open Length (mm)	Closed Length (mm)	Type	UPPER MOUNT BUSH KIT		Type	LOWER MOUNT BUSH KIT	
				Original Kit	Bushes only Replacement		Original Kit	Bushes only Replacement
N180	690	406	E4005	110-034-082	110-034-082	E4005-S	110-A42-124 ¹	OMEB11
N181 ¹	537	317	P4184	SMP501	OMEB42	P4184	SMP501	OMEB42
N182 ¹	608	352	P4205	SMP474	OMEB13	E4026-S	110-A42-074	N/A
N183S ¹	390	281	P-	SMP633	N/A	E4063-BS	110-110-100	N/A
N183S ¹ (02/11 on)	390	281	P-	SMP633	N/A	E4063-BS	110-110-112	N/A
N184 ¹	379	255	E4051-S	110-110-076	N/A	E4051-S	110-110-076	N/A
N185	567	341	E4001	110-043-065 ¹	OMEB14	E4063-S	110-110-100	N/A
N186S	426	298	P-	N/A	N/A	E4055-BS	110-110-075	N/A
N187 ¹	360	240	P4205	SMP475 ¹	OMEB13	E4050	TBA	110-034-181
N188S	-	-	-	-	-	-	-	-
N189 ¹	600	360	E4005	110-034-070	OMEB15	E4005BS	110-034-080	-
N190	658	394	E4057-S	110-110-085	N/A	E4005-S	110-110-086 ¹	-
N191	589	349	P4205	SMP474	OMEB13	E4005-S	110-034-070	OMEB15
N192S	589	424	P-	SMP659 ¹	SMP659 ¹	E4055-BS	110-110-101	-
N193	661	391	P4203	SMP493	-	E4040-BS	110-110-102 ¹	N/A
N194 ¹	360	240	P4205	SMP475 ¹	OMEB13	E4050	TBA	110-034-181
N195	560	340	P4204	SMP493	-	E4051-S	110-110-103	-
N196 ¹	576	348	P4184	SMP374	OMEB42	E-TBA	TBA	TBA
N197 ¹	652	397	E4005	110-034-070	OMEB15	E-4005	110-034-070	OMEB15
N198 ¹	615	375	E-TBA	TBA	TBA	E-TBA	TBA	TBA
N199 ¹	440	290	P4203	SMP493	SMP493	E4050-BS	110-110-122	110-110-122
N200 ¹	610	360	P4204	SMP493	SMP493	E4005	110-034-069 ¹	OMEB40
N201S ¹	543	405	P-	SMP633/626	SMP633/626	E4050-S	110-110-122	110-110-122
N202 ¹	577	353	P4184	SMP569	SMP569	E4005	SMP621	OMEB40
N203S ¹	472	327	P	Use OE Bushes	N/A	E4055-BS	110-110-075	110-110-075
N204 ¹	576	345	P4158	SMP641	N/A	E4051-BS	110-110-076	N/A
N205	507	312	P4213	SMP665 ¹	N/A	E4051-BS	110-110-092 ¹	N/A
N206S ¹	602	399	P-	Nut only	N/A	N/A	N/A	N/A
N207S ¹	602	399	P-	Nut only	N/A	N/A	N/A	N/A
N208S	608	433	P4214	Use OE Bushes	Use OE Bushes	E4066	N/A	110-110-110
N209	610	360	P4204	SMP493	N/A	E4005	110-034-063 ¹	OMEB40
N210 ¹	610	360	P4204	SMP493	N/A	E4005	110-034-063 ¹	OMEB40
N211 ¹	576	348	P4184	SMP374	OMEB42	E4026	110-034-181	110-034-181
N212 ¹	618	375	E4053	110-110-105 ¹	N/A	E4026	110-034-181	110-034-181
N217S	610	395	P-	N/A	N/A	N/A	N/A	N/A
N218S	610	395	P-	N/A	N/A	N/A	N/A	N/A
N219S	516	357	P	Use OE Bushes	N/A	OEM	OEM	N/A
N220	658	394	E4057-S	110-110-085	N/A	E-4005-S	110-110-086 ¹	N/A
OME007 ¹	600	359	E4004	110-034-003 ¹	N/A	E4003	110-034-003 ¹	N/A
OME013	473	292	E4001	110-034-071	OMEB14	E4001	110-034-071	OMEB14
OME014	495	305	E4001	110-034-071	OMEB14	E4001	110-034-071	OMEB14
OME015	415	256	P4175	SMP333 ¹	OMEB13	E4001	110-034-071	OMEB14
OME018 ¹	585	359	E4003	110-034-003 ¹	N/A	E4003	110-034-003 ¹	N/A
OME023 ¹	429	270	E4001	110-034-071	OMEB14	E4001	110-034-071	OMEB14
OME025	415	256	P4175	SMP333 ¹	OMEB13	E4001	110-034-071	OMEB14
OME027	497	297	P4175	SMP333 ¹	OMEB13	E4001	110-034-071	OMEB14
OME028	450	281	P4169	SMP474	OMEB13	E4028-S	110110009	N/A
OME029	502	314	E4028-S	110110009	N/A	E4028-S	110110009	N/A
OME030 ¹	470	302	E4028-S	110110009	N/A	E4028-S	110110009	N/A
OME031	627	379	P4175	SMP333 ¹	OMEB13	E4001	110-034-071	OMEB14
OME032 ¹	608	369	P4175	SMP333 ¹	OMEB13	E4001	110-034-071	OMEB14
OME033 ¹	615	382	P-	SMP636	OMEB13	E4005-S	110-034-072	OMEB17
OME034	481	284	P4175	SMP333 ¹	OMEB13	E4001	110-034-071	OMEB14
OME035	495	299	E4001	110-034-071	OMEB14	E4001	110-034-071	OMEB14
OME036	560	335	E	6082183 ¹	N/A	E	6082183 ¹	N/A

Note: Bush kits with part numbers starting with SMP indicate the kits have the urethane bush, mounting nut & washers.

1. When remaining stock is exhausted no further product will be available.

See page 165 for legend of mount types.

SPECIFICATIONS - SHOCK ABSORBERS

SHOCK ABSORBER MOUNT TYPES

Mount Type Pin Part No.	Dimensions (mm) Thread Length X Dia	OME Replacement Part No.
P4161	62 x M10 x 1.5	OMEB13
P4169	53 x M10 x 1.25	OMEB13
P4170	73 x M10 x 1.5	OMEB13
P4175	58 x M10 x 1.5	OMEB13
P4184	71 x M12 x 1.25	OMEB42
P4203	85 x M14 x 1.5	Use original
P4204	77 x M14 x 1.5	Use original
P4205	54 x M10 x 1.25	OMEB13

Mount Type Eye Part No.	Dimensions (mm) OD x ID x L	Mounting Kit Replacement Part No.
E4001	37 x 25.3 x 24.3	OMEB14
E4003	42.6 x 37.7 x 19.5	Not available
E4005	44.2 x 31.7 x 30	OMEB36 *OMEB40
E4026	37 x 27 x 25	OMEB10
E4028	38.4 x 25.1 x 23	Not available
E4032	46.7 x 36.6 x 33	Not available
E4040	46 x 37 x 30	Not available
E4050	45 x 39 x 35	Not available
E4055	50 x 40.2 x 34	Not available
E4057	42 x 32.5 x 29	Not available

T-CROSS PIN MOUNTING

S-BUSH WITH SLEEVE

B-BONDED BUSH

*Special Bush for N22F¹, N29/N29C¹ Lower Rear Mount

1. When remaining stock is exhausted no further product will be available.

SPECIFICATIONS - TORSION BARS

TORSION BARS

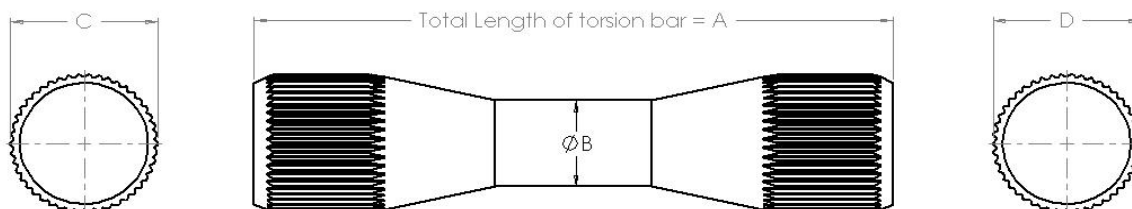

Part Number	A ± 2.0	B ± 0.15	C $+0 -0.2$	C Spline No.	D $+0 -0.2$	D Spline No.
303001	1160	30.4	47.0	46	47.0	46
303002	1210	32.8	47.0	46	47.0	46
303003	1065	23.4	33.0	43	30.75	40
303004	1000	24.5	33.0	43	33.0	43
303005	925	25.7	30.75	40	30.75	40
303006	1365	27.5	30.0	39	30.75	40
303007	890	26.7	30.0	39	30.0	39
303008	1205	26.0	30.0	39	30.0	39
303009	1277.5	25.5	30.0	39	30.75	40
303010	1277.5	27.3	30.0	39	30.75	40
303011	1307.5	27.5	30.0	39	30.75	40
303012	1142	26.0	36.0	47	36.0	47
303013	1024	27.0	30.8	40	30.75	40
303014	1225	30.3	37.9	6 side hex	37.85	6 side hex

All dimensions in millimetres (mm)

SPECIFICATIONS - STABILISERS

STEERING STABILISERS

Part Number	Upper Mount Type (mm)	Lower Mount Type (mm)	Open Length (mm)	Closed Length (mm)	Mounting Kit No.	No. of Kits	OME Bush Kit
OMESD01	Eye with Bush	Eye with Bush	552	342	142995	1	
OMESD02	Eye with Bush & Sleeve	Eye with Bush & Sleeve	655	394	No Kit		
OMESD11	Pin 60 x 9.5	Pin 60 x 9.5	516	308	140276	1	
OMESD16 ¹	Pin 60 x 9.5	Pin 60 x 9.5	535	314	140276	1	
OMESD17 ¹	Eye with Bush	Eye with Bush	622	373	142387	1	
OMESD21	Pin 60 x 9.5	Eye with Bush	542	340	140504	1	
OMESD22	Eye with Bush	Eye with Bush	537	328	No Kit		OMEB14
OMESD23	Eye with Bush	Eye with Bush	454	316	142995	1	
OMESD24	Eye with Bush	Eye with Bush	651	417	142995	1	
OMESD30	Eye with Bush & Sleeve	Eye with Bush & Sleeve	448	290	No Kit		
OMESD31 ¹	Eye with Bush & Sleeve	Eye with Bush & Sleeve	577	392	No Kit		
OMESD32	Pin 60 x 9.5	Eye with Bush & Sleeve	680	440	500555	1	
OMESD33	Eye with Bush & Mounting Pin	Eye with Bush	611	364	140953	1	
OMESD34	Eye with Bush & Sleeve	Eye with Bush	575	347	No Kit		
OMESD35	Eye with Bush & Sleeve	Eye with Bush & Sleeve	503	311	No Kit		
OMESD36	Pin 60 x 9.5	Pin 60 x 9.5	484	289	140276	1	
OMESD40	Eye with Bush	Eye with Bush & Sleeve	499	309	500498	1	
OMESD47	Eye with Bush	Eye with Bush	750	510	142995	1	
OMESD48	Eye with Bush	Eye with Bush & Sleeve	499	310	500498	1	142864 (Boot)

1. When remaining stock is exhausted no further product will be available.

RECOMMENDED FITTING TIMES

COIL SPRINGS SYSTEMS

All Coil Spring Models (Except Land Rovers) Fitment of 4 Shock Absorbers & 4 OME coil springs	2.0 hours
Land Rover All Coil Spring Models Fitment of all the above plus additional time to remove front shock absorber towers	2.5 hours
Torsion Bar Front with Rear Coil Suspension Fitment of 4 Shock Absorbers, 2 OME coil springs & front torsion bar adjustment	2.0 hours
Coil Front with Rear Leaf Suspension Fitment of 4 Shock Absorbers, 2 OME coil springs & 2 OME Leaf springs	3.5 hours
Coil Over Front Strut with Rear Coil Suspension Fitment of 2 Shock Absorbers, 2 OME struts & 4 OME coil springs	3.0 hours
Coil over Front Strut with Leaf Rear Springs Fitment of 2 Shock Absorbers, 2 Struts, 2 Coils & 2 Leaf Springs	4.0 hours

LEAF SPRING SYSTEMS

All Leaf spring Models (Except HiLux) Fitment of 4 Shock Absorbers, 4 OME Leaf Springs, and U bolts and spring bushes as required	5.0 hours
Toyota HiLux All Leaf Spring Models Fitment of all the above plus additional work required to strengthen front spring seat mount	6.0 hours
Front Torsion Bar with Rear Leaf Spring Models Fitment of 4 Shock Absorbers, 2 OME rear leaf springs, U bolts, spring bushes and front torsion bar adjustment	3.0 hours

CARTRIDGE REPLACEMENT

Additional work required to install cartridge per strut	0.5 hours
---	-----------

TORSION BARS

Remove and replace a set of Bars (no removal complications)	1.5 hours
Remove and replace a set of Bars (removal complications eg. OE splines corroded)	2.5 hours

MISCELLANEOUS

Caster kits	2.0 hours
Steering stabilisers	0.5 hours
Greasable shackles (complete vehicle set)	2.0 hours

FRONT END WHEEL ALIGNMENT ADJUSTMENTS

	Price
Live axle front end	
Independent front end	

The above fitting times are only a guide, and additional time may be involved due to vehicle modifications or pre-existing accessories which can interfere with the fitment of the suspension.



DISTRIBUTED BY

ARB CORPORATION LIMITED HEAD OFFICE

42-44 Garden Street, Kilsyth,
Victoria 3137 Australia.

T (03) 9761 6622

F (03) 9761 6807

E sales@arb.com.au

W arb.com.au

ARB EUROPE S.R.O

Na Dlouhém č.80,
DC2 251 01

Říčany - Jazlovce

Czech Republic

T +420-323-040-900

E sales@arbeurope.com

ARB MIDDLE EAST FZE

LIU15, RA07AB05

Jebel Ali Freezone - North

Dubai, United Arab Emirates

T +971 50 948 9284

E purchasingme@arb.com.au

AIR LOCKER INC. (ARB USA)

4810 D St NW #103

Auburn, WA United States

T +1 425 264 1391

E sales@arbusa.com

W arbusa.com

ARB OFFROAD LTD (ARB THAILAND)

Eastern Seaboard Industrial Estate

Building GW 1, 2nd Floor 300/56,

Moo 1, T.Tasit, A Pluakdaeng

Rayong 21140, Thailand

T +66 38 929 672

E sales.thailand@arb.com.au

W www.arb.co.th